

INTERNATIONAL
STANDARD

ISO
492

Third edition
1994-12-01

**Rolling bearings — Radial bearings —
Tolerances**

iTeh STANDARD PREVIEW
Roulements — Roulements radiaux — Tolérances
(standards.iteh.ai)

ISO 492:1994

<https://standards.iteh.ai/catalog/standards/sist/ec755da4-e60f-4543-b6cf-cfd3fd171bc/iso-492-1994>



Reference number
ISO 492:1994(E)

Foreword

ISO (the International Organization for Standardization) is a worldwide federation of national standards bodies (ISO member bodies). The work of preparing International Standards is normally carried out through ISO technical committees. Each member body interested in a subject for which a technical committee has been established has the right to be represented on that committee. International organizations, governmental and non-governmental, in liaison with ISO, also take part in the work. ISO collaborates closely with the International Electrotechnical Commission (IEC) on all matters of electrotechnical standardization.

Draft International Standards adopted by the technical committees are circulated to the member bodies for voting. Publication as an International Standard requires approval by at least 75 % of the member bodies casting a vote.

International Standard ISO 492 was prepared by Technical Committee ISO/TC 4, *Rolling bearings*, Subcommittee SC 4, *Tolerances*.

This third edition cancels and replaces the second edition (ISO 492:1986). The definitions have been deleted and a new symbol, ΔD_{1s} , has been added. Changes and additions have been made to tables 1 to 10, 12, 16 and 18. A new table 19 specifies flange outside diameter tolerances. Tolerances for tapered bores, taper 1:12, have been changed (table 20), and those for taper 1:30 have been added (table 21).

Annex A of this International Standard is for information only.

© ISO 1994

All rights reserved. Unless otherwise specified, no part of this publication may be reproduced or utilized in any form or by any means, electronic or mechanical, including photocopying and microfilm, without permission in writing from the publisher.

International Organization for Standardization
Case Postale 56 • CH-1211 Genève 20 • Switzerland

Printed in Switzerland

Rolling bearings — Radial bearings — Tolerances

1 Scope

This International Standard specifies tolerances for boundary dimensions (except chamfer dimensions) and the running accuracy of radial rolling bearings specified in ISO 15 and ISO 355.

This International Standard does not apply to certain radial bearings of particular types (for example, drawn cup needle roller bearings) or for particular fields of application (for example, airframe bearings and instrument precision bearings). Tolerances for such bearings are given in the relevant International Standards.

Chamfer dimension limits are given in ISO 582.

2 Normative references

The following standards contain provisions which, through reference in this text, constitute provisions of this International Standard. At the time of publication, the editions indicated were valid. All standards are subject to revision, and parties to agreements based on this International Standard are encouraged to investigate the possibility of applying the most recent editions of the standards indicated below. Members of IEC and ISO maintain registers of currently valid International Standards.

ISO 15:1981, *Rolling bearings — Radial bearings — Boundary dimensions — General plan.*

ISO 355:1977, *Rolling bearings — Metric tapered roller bearings — Boundary dimensions and series designations.*

ISO 1132:1980, *Rolling bearings — Tolerances — Definitions.*

ISO 5593:1984, *Rolling bearings — Vocabulary.*

3 Definitions

For the purposes of this International Standard, the definitions given in ISO 1132 and ISO 5593 apply.

4 Symbols

The symbols (except those for tolerances) shown in the figures and the values given in the tables denote nominal dimensions unless otherwise specified.

4.1 Symbols for boundary dimensions and running accuracy

See figure 1 for symbols for the dimensions.

d	bore diameter
d_1	diameter at the theoretical large end of a basically tapered bore
Δd_s	deviation of a single bore diameter
Δd_{mp}	deviation of mean bore diameter in a single plane (for a basically tapered bore, Δd_{mp} refers to the theoretical small end of the bore)
Δd_{1mp}	deviation of mean bore diameter in a single plane at the theoretical large end of a basically tapered bore
V_{dp}	variation of bore diameter in a single radial plane
V_{dmp}	variation of mean bore diameter (this applies only to a basically cylindrical bore)
D	outside diameter
D_1	outside diameter of outer ring flange
ΔD_s	deviation of a single outside diameter
ΔD_{mp}	deviation of mean outside diameter in a single plane
ΔD_{1s}	deviation of a single outside diameter of outer ring flange
V_{Dp}	variation of outside diameter in a single radial plane
V_{Dmp}	variation of mean outside diameter
B	inner ring width
ΔB_s	deviation of a single inner ring width
V_{Bs}	variation of inner ring width
C	outer ring width
C_1	outer ring flange width
ΔC_s	deviation of a single outer ring width
ΔC_{1s}	deviation of a single outer ring flange width
V_{Cs}	variation of outer ring width
V_{C1s}	variation of outer ring flange width
K_{ia}	radial runout of inner ring of assembled bearing
K_{ea}	radial runout of outer ring of assembled bearing
S_d	runout of inner ring reference face (back face, where applicable) with respect to the bore

S_D	variation of outer ring outside surface generatrix inclination with respect to the outer ring reference face (back face)
S_{D1}	variation of outer ring outside surface generatrix inclination with respect to the outer ring flange back face
S_{ia}	runout of inner ring face (back face) with respect to the raceway of assembled bearing
S_{ea}	runout of outer ring face (back face) with respect to the raceway of assembled bearing
S_{ea1}	runout of outer ring flange back face with respect to the raceway of assembled bearing
α	taper angle (half the cone angle) of inner ring bore

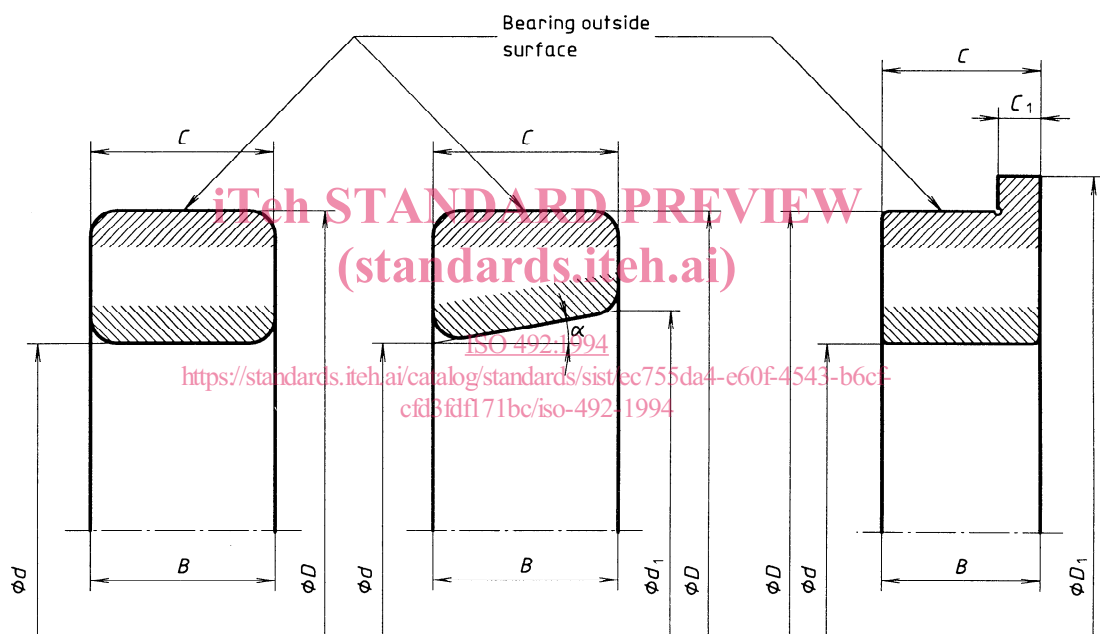

Figure 1 — Symbols for boundary dimensions

4.2 Additional symbols for tapered roller bearings

See figure 2.

- T bearing width
- ΔT_s deviation of the actual bearing width
- T_1 effective inner subunit width
- ΔT_{1s} deviation of the actual effective inner subunit width
- T_2 effective outer subunit width
- ΔT_{2s} deviation of the actual effective outer subunit width

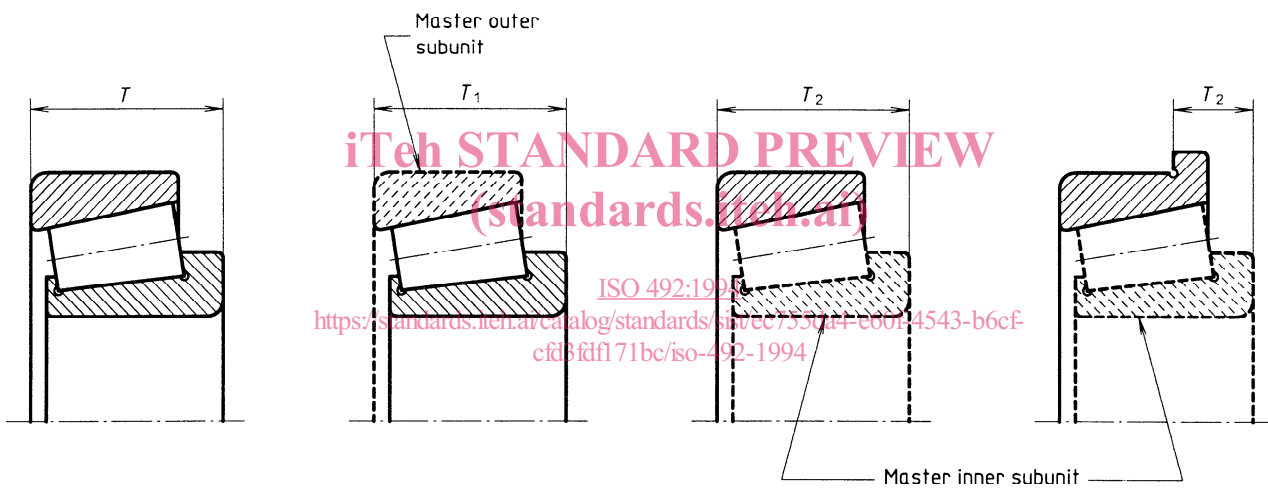

Figure 2 — Additional symbols for tapered roller bearings

5 Tolerances

5.1 Radial bearings except tapered roller bearings

The bore diameter tolerances given in this subclause apply to basically cylindrical bores. Tolerances for tapered bores are given in 5.4.

The diameter series referred to in tables 1 to 8 are those defined in ISO 15.

5.1.1 Normal tolerance class

See tables 1 and 2.

Table 1 — Inner ring

Tolerance values in micrometres

d mm	Δd_{mp}		V_{dp}			V_{dmp}	K_{ia}	ΔB_s			V_{Bs}
			Diameter series					all	normal	modified ¹⁾	
	high	low	9	0,1	2,3,4	max.	max.				max.
$0,6 \leq d \leq 2,5$	0	- 8	10	8	6	6	10	0	- 40	—	12
$2,5 < d \leq 10$	0	- 8	10	8	6	6	10	0	- 120	- 250	15
$10 < d \leq 18$	0	- 8	10	8	6	6	10	0	- 120	- 250	20
$18 < d \leq 30$	0	- 10	13	10	8	8	13	0	- 120	- 250	20
$30 < d \leq 50$	0	- 12	15	12	9	9	15	0	- 120	- 250	20
$50 < d \leq 80$	0	- 15	19	15	11	11	20	0	- 150	- 380	25
$80 < d \leq 120$	0	- 20	25	25	15	15	25	0	- 200	- 380	25
$120 < d \leq 180$	0	- 25	31	31	19	19	30	0	- 250	- 500	30
$180 < d \leq 250$	0	- 30	38	38	23	23	40	0	- 300	- 500	30
$250 < d \leq 315$	0	- 35	44	44	26	26	50	0	- 350	- 500	35
$315 < d \leq 400$	0	- 40	50	50	30	30	60	0	- 400	- 630	40
$400 < d \leq 500$	0	- 45	56	56	34	34	65	0	- 450	—	50
$500 < d \leq 630$	0	- 50	63	63	38	38	70	0	- 500	—	60
$630 < d \leq 800$	0	- 75	—	—	—	—	80	0	- 750	—	70
$800 < d \leq 1\ 000$	0	- 100	—	—	—	—	90	0	- 1\ 000	—	80
$1\ 000 < d \leq 1\ 250$	0	- 125	—	—	—	—	100	0	- 1\ 250	—	100
$1\ 250 < d \leq 1\ 600$	0	- 160	—	—	—	—	120	0	- 1\ 600	—	120
$1\ 600 < d \leq 2\ 000$	0	- 200	—	—	—	—	140	0	- 2\ 000	—	140

1) This refers to the rings of single bearings made for paired or stack assemblies.

Table 2 — Outer ring

Tolerance values in micrometres

D mm	ΔD_{mp}		$V_{Dp}^{1)}$				$V_{Dmp}^{1)}$	K_{ea}	ΔC_s $\Delta C_{1s}^{2)}$		V_{Cs} $V_{C1s}^{2)}$
			Open bearings		Capped bearings						
			Diameter series								
			9	0,1	2,3,4	2,3,4					
high	low	max.				max.	max.	high	low	max.	
$2,5 \leq D \leq 6$	0	-8	10	8	6	10	6	15	Identical to ΔB_s and V_{Bs} of inner ring of same bearing		
$6 < D \leq 18$	0	-8	10	8	6	10	6	15			
$18 < D \leq 30$	0	-9	12	9	7	12	7	15			
$30 < D \leq 50$	0	-11	14	11	8	16	8	20			
$50 < D \leq 80$	0	-13	16	13	10	20	10	25			
$80 < D \leq 120$	0	-15	19	19	11	26	11	35			
$120 < D \leq 150$	0	-18	23	23	14	30	14	40			
$150 < D \leq 180$	0	-25	31	31	19	38	19	45			
$180 < D \leq 250$	0	-30	38	38	23	—	23	50			
$250 < D \leq 315$	0	-35	44	44	26	—	26	60			
$315 < D \leq 400$	0	-40	50	50	30	—	30	70			
$400 < D \leq 500$	0	-45	56	56	34	—	34	80			
$500 < D \leq 630$	0	-50	63	63	38	—	38	100			
$630 < D \leq 800$	0	-75	94	94	55	—	55	120			
$800 < D \leq 1\ 000$	0	-100	125	125	75	—	75	140			
$1\ 000 < D \leq 1\ 250$	0	-125	—	—	—	—	—	160			
$1\ 250 < D \leq 1\ 600$	0	-160	—	—	—	—	—	190			
$1\ 600 < D \leq 2\ 000$	0	-200	—	—	—	—	—	220			
$2\ 000 < D \leq 2\ 500$	0	-250	—	—	—	—	—	250			

NOTE — The tolerances for the outside diameter of an outer ring flange D_1 are given in table 19.

- 1) Applies before mounting and after removal of internal or external snap ring.
- 2) Applies to groove ball bearings only.

5.1.2 Tolerance class 6

See tables 3 and 4.

Table 3 — Inner ring

Tolerance values in micrometres

d mm	Δd_{mp}		V_{dp}			V_{dmp}	K_{ia}	ΔB_s			V_{Bs}
			Diameter series					all	normal	modified ¹⁾	
	high	low	9	0,1	2,3,4	max.	max.				high
$0,6 \leq d \leq 2,5$	0	-7	9	7	5	5	5	0	-40	—	12
$2,5 < d \leq 10$	0	-7	9	7	5	5	6	0	-120	-250	15
$10 < d \leq 18$	0	-7	9	7	5	5	7	0	-120	-250	20
$18 < d \leq 30$	0	-8	10	8	6	6	8	0	-120	-250	20
$30 < d \leq 50$	0	-10	13	10	8	8	10	0	-120	-250	20
$50 < d \leq 80$	0	-12	15	15	9	9	10	0	-150	-380	25
$80 < d \leq 120$	0	-15	19	19	11	11	13	0	-200	-380	25
$120 < d \leq 180$	0	-18	23	23	14	14	18	0	-250	-500	30
$180 < d \leq 250$	0	-22	28	28	17	17	20	0	-300	-500	30
$250 < d \leq 315$	0	-25	31	31	19	19	25	0	-350	-500	35
$315 < d \leq 400$	0	-30	38	38	23	23	30	0	-400	-630	40
$400 < d \leq 500$	0	-35	44	44	26	26	35	0	-450	—	45
$500 < d \leq 630$	0	-40	50	50	30	30	40	0	-500	—	50

1) This refers to the rings of single bearings made for paired or stack assemblies.

Table 4 — Outer ring

Tolerance values in micrometres

D mm	ΔD_{mp}		$V_{Dp}^{1)}$				$V_{Dmp}^{1)}$	K_{ea}	ΔC_s $\Delta C_{1s}^{2)}$		V_{Cs} $V_{C1s}^{2)}$
			Open bearings		Capped bearings						
			Diameter series								
			9	0,1	2,3,4	0,1,2,3,4					
high	low	max.				max.	max.	high	low	max.	
$2,5 \leq D \leq 6$	0	-7	9	7	5	9	5	8	Identical to ΔB_s and V_{Bs} of inner ring of same bearing		
$6 < D \leq 18$	0	-7	9	7	5	9	5	8			
$18 < D \leq 30$	0	-8	10	8	6	10	6	9			
$30 < D \leq 50$	0	-9	11	9	7	13	7	10			
$50 < D \leq 80$	0	-11	14	11	8	16	8	13			
$80 < D \leq 120$	0	-13	16	16	10	20	10	18			
$120 < D \leq 150$	0	-15	19	19	11	25	11	20			
$150 < D \leq 180$	0	-18	23	23	14	30	14	23			
$180 < D \leq 250$	0	-20	25	25	15	—	15	25			
$250 < D \leq 315$	0	-25	31	31	19	—	19	30			
$315 < D \leq 400$	0	-28	35	35	21	—	21	35			
$400 < D \leq 500$	0	-33	41	41	25	—	25	40			
$500 < D \leq 630$	0	-38	48	48	29	—	29	50			
$630 < D \leq 800$	0	-45	56	56	34	—	34	60			
$800 < D \leq 1\ 000$	0	-60	75	75	45	—	45	75			

NOTE — The tolerances for the outside diameter of an outer ring flange D_1 are given in table 19.

- 1) Applies before mounting and after removal of internal or external snap ring.
- 2) Applies to groove ball bearings only.

5.1.3 Tolerance class 5

See tables 5 and 6.

Table 5 — Inner ring

Tolerance values in micrometres

d mm	Δd_{mp}		V_{dp}		V_{amp}	K_{ia}	S_d	$S_{ia}^{1)}$	ΔB_s			V_{Bs}
			Diameter series						all	normal	modified ²⁾	
	high	low	9	0,1,2,3,4	max.	max.	max.	max.				high
0,6 ≤ d ≤ 2,5	0	-5	5	4	3	4	7	7	0	-40	-250	5
2,5 < d ≤ 10	0	-5	5	4	3	4	7	7	0	-40	-250	5
10 < d ≤ 18	0	-5	5	4	3	4	7	7	0	-80	-250	5
18 < d ≤ 30	0	-6	6	5	3	4	8	8	0	-120	-250	5
30 < d ≤ 50	0	-8	8	6	4	5	8	8	0	-120	-250	5
50 < d ≤ 80	0	-9	9	7	5	5	8	8	0	-150	-250	6
80 < d ≤ 120	0	-10	10	8	5	6	9	9	0	-200	-380	7
120 < d ≤ 180	0	-13	13	10	7	8	10	10	0	-250	-380	8
180 < d ≤ 250	0	-15	15	12	8	10	11	13	0	-300	-500	10
250 < d ≤ 315	0	-18	18	14	9	13	13	15	0	-350	-500	13
315 < d ≤ 400	0	-23	23	18	12	15	15	20	0	-400	-630	15

1) Applies to groove ball bearings only.

2) This refers to the rings of single bearings made for paired or stack assemblies.

ITeH STANDARD PREVIEW
(standards.iteh.ai)

Table 6 — Outer ring

Tolerance values in micrometres

<https://standards.iteh.ai/catalog/standards/sist/ec755da4-e60f-4543-b6cf-cfd3fd171bc/iso-492-1994>

D mm	ΔD_{mp}		V_{Dp}		V_{Dmp}	K_{ea}	$S_D^{1)}$ $S_{D1}^{2)}$	$S_{ea}^{1)2)}$	$S_{ea1}^{2)}$	ΔC_s		V_{Cs} $V_{C1s}^{2)}$
			Diameter series							high	low	
	high	low	9	0,1,2,3,4	max.	max.	max.	max.	max.			max.
2,5 ≤ D ≤ 6	0	-5	5	4	3	5	8	8	11	Identical to ΔB_s of inner ring of same bearing	5	
6 < D ≤ 18	0	-5	5	4	3	5	8	8	11		5	
18 < D ≤ 30	0	-6	6	5	3	6	8	8	11		5	
30 < D ≤ 50	0	-7	7	5	4	7	8	8	11		5	
50 < D ≤ 80	0	-9	9	7	5	8	8	10	14		6	
80 < D ≤ 120	0	-10	10	8	5	10	9	11	16		8	
120 < D ≤ 150	0	-11	11	8	6	11	10	13	18		8	
150 < D ≤ 180	0	-13	13	10	7	13	10	14	20		8	
180 < D ≤ 250	0	-15	15	11	8	15	11	15	21		10	
250 < D ≤ 315	0	-18	18	14	9	18	13	18	25		11	
315 < D ≤ 400	0	-20	20	15	10	20	13	20	28	13		
400 < D ≤ 500	0	-23	23	17	12	23	15	23	33	15		
500 < D ≤ 630	0	-28	28	21	14	25	18	25	35	18		
630 < D ≤ 800	0	-35	35	26	18	30	20	30	42	20		

NOTE — The tolerances for the outside diameter of an outer ring flange D_1 are given in table 19.

1) Does not apply to bearings with flanged outer ring.

2) Applies to groove ball bearings only.