



Standard Specification for Mechanical Cold Expansion Insert Fitting With Compression Sleeve for Cross-linked Polyethylene (PEX) Tubing¹

This standard is issued under the fixed designation F 1865; the number immediately following the designation indicates the year of original adoption or, in the case of revision, the year of last revision. A number in parentheses indicates the year of last reapproval. A superscript epsilon (ϵ) indicates an editorial change since the last revision or reapproval.

^{ε1} NOTE—Section 10 was editorially revised in December 2002.

1. Scope

1.1 This specification covers mechanical cold expansion insert fittings with compression sleeve suitable for use with cross-linked polyethylene PEX plastic tubing in $\frac{3}{8}$, $\frac{1}{2}$, $\frac{5}{8}$, $\frac{3}{4}$, 1in. and larger nominal diameters that meet the requirements of Specifications F 876 and F 877. These fittings are intended for use in 100 psi (689.5 kPa) cold and hot water distributions systems operating at temperatures up to and including 180° F (82°C). Included are the requirements for materials, workmanship, dimensions, and markings to be used on the fittings and compression sleeves

1.2 The values stated in inch-pounds units are to be regarded as the standard. The values given in parentheses are mathematical conversions to SI units which are provided for provided for information only and are not considered the standard.

1.3 *This standard does not purport to address all of the safety concerns, if any, associated with its use. It is the responsibility of the user of this standard to establish appropriate safety and health practices and determine the applicability of regulatory limitations prior to use.*

2. Referenced Documents

2.1 ASTM Standards:

- B 16 Specification for Free-Cutting Brass Rod, Bar, and Shapes for Use in Screw Machines²
- B 140/B 140M Specification for Copper-Zinc-Lead (Leaded Red Brass or Hardware Bronze) Rod, Bar and Shapes²
- B 283 Specification for Copper and Copper-Alloy Die Forgings (Hot Pressed)²
- D 1600 Terminology for Abbreviated Terms Relating to Plastics³
- D 2122 Test Method for Determining Dimensions of Ther-

- moplastic Pipe and Fittings⁴
- E 18 Test Method for Rockwell Hardness and Superficial Hardness of Metallic Materials⁵
- F 412 Terminology Relating to Plastic Piping Systems⁴
- F 876 Specification for Crosslinked Polyethylene (PEX) Tubing⁴
- F 877 Specification for Crosslinked Polyethylene (PEX) Plastic Hot- and Cold-Water Distribution Systems⁴
- 2.2 *ASME Standards:*⁶
 - B 1.20.1 Pipe Threads General Purpose (inch)
 - B 16.18 Cast Copper Alloy Solder Joint Pressure Fittings
 - B 16.22 Wrought Copper and Copper Alloy Solder Joint Pressure Fittings
- 2.3 *NSF International Standards:*⁷
 - NSF 14 Plastic Piping Components and Related Materials
 - NSF 61 Drinking Water System Components-Health Effects
- 2.4 *MSS Standard:*⁸
 - SP-104 Wrought Copper Solder Joint Pressure Fittings

3. Terminology

3.1 *Definitions:* Definitions are in accordance with Terminology F 412 and abbreviations are in accordance with Terminology D 1600 unless otherwise indicated.

4. Classification

4.1 This specification covers one class of mechanical cold expansion insert fittings with compression sleeve suitable for use with PEX tubing that meets the requirements of Specification F 876 and F 877.

5. Materials and Manufacture

5.1 *Fittings*—The fittings shall be made from one of the following metals:

5.1.1 *Machined Brass Fittings*—Machined brass fittings

⁴ *Annual Book of ASTM Standards*, Vol 08.04.

⁵ *Annual Book of ASTM Standards*, Vol 03.01.

⁶ Available from American Society of Mechanical Engineers, United Engineering Center, 345 E. 47th St., New York, NY 10017.

⁷ Available from the National Sanitation Foundation, P.O. Box 1468, Ann Arbor, MI 48106.

⁸ Available from Manufacturer's Standardization Society of the Valve and Fittings Industry, 5203 Leesburg Pike, Suite 502, Falls Church, VA 22041.

¹ This standard is under the jurisdiction of Committee F17 on Plastic Piping Systems and is the direct responsibility of Subcommittee F17.10 on Fittings.

Current edition approved May 10, 2002. Published July 2002.

Originally published as F1865-98. Last previous edition F 1865-98.

² *Annual Book of ASTM Standards*, Vol 02.01.

³ *Annual Book of ASTM Standards*, Vol 08.01.

shall be made from material meeting the requirements of Specification B 140 copper alloy UNS C31400, Specification B 16 Copper alloy UNS C38500, or DIN 17660 – CuZn39Pb3.

5.1.2 *Forged Brass Fittings*—Forged brass fittings shall be made from material meeting the requirements of Specification B 283 Copper alloy UNS C37700, or DIN 17660-CuZn40Pb2.

5.1.3 *Compression Sleeves*—Compression sleeves shall be made from material meeting the requirements of Specification B 140 copper alloy UNS C37700, Specification B 16 Copper alloy UNS C38500, or DIN 17660-CuZn39PB3.

6. General Requirements

6.1 The following sections of Specification F 877 constitute a part of this specification:

- 6.1.1 Requirements,
- 6.1.2 Test Methods, and
- 6.1.3 Retest and Rejection

6.2 In addition, when a section with a title identical to that referenced in 6.1, above, appears in this specification, it contains additional requirements that supplement those appearing in F 877.

6.3 *Dimensions*—Randomly selected fitting or fittings shall be used to determine dimensions. Measurements shall be made in accordance with Test Method D 2122. Determine the diameters by making measurements at four points spaced approximately 45° apart around the circumference. Inspection and gauging of solder joint ends shall be in accordance with ANSI B 16.18, ANSI B 16.22, or MSS SP-104. Inspection and gauging of taper pipe threads shall be in accordance with ANSI/ASME G1.20.1. All fittings that will be subjected to secondary processes of mechanical marking that affect their dimensional tolerances shall be tested in their final marked configuration.

7. Dimensions

7.1 *Dimensions and Tolerances*—The dimensions and tolerances of fittings and compression sleeves shall be as shown in Fig. 1 and Fig. 2 when measured in accordance with 6.3.

7.1.1 *Alignment*—The maximum angular variation of any opening shall not exceed ½° off the true centerline axis.

7.1.2 *Fittings with Solder Joint Ends*—Solder joint ends shall be in accordance with ASME B 16.22, ASME B 16.18 or MSS SP-104

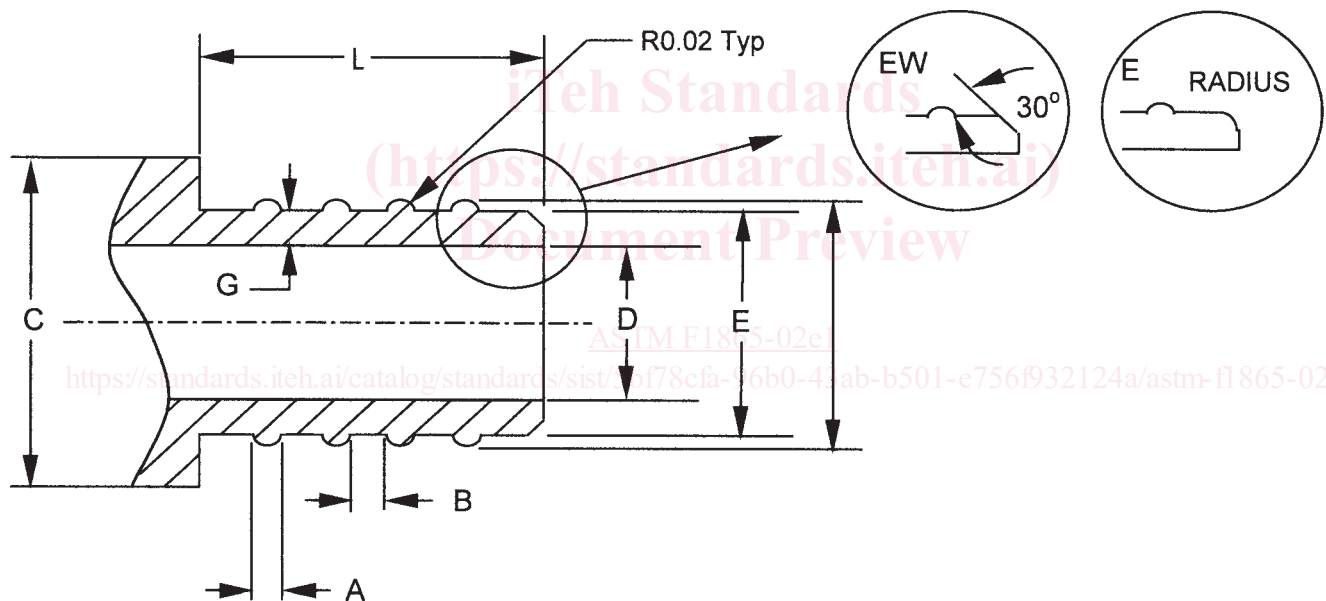

Standard Size	Inches		B	C	D	E	F	G	EW	L
	A	Number	Gap	Stop	Inside	Insert	Rib	Minimum	EX	
	Rib	of Ribs	Width	Dia. min	Dia. min	Diameter	Diameter	Wall	Depth	
	Width		Typ							
	Typ									
3/8 in.	0.04 + 0.01	4	0.071 ± 0.010	0.620	0.30	0.370 + 0.008	0.410 + 0.008	0.025	0.020	0.59
1/2 in.	0.04 + 0.01	4	0.071 ± 0.010	0.78	0.40	0.510 + 0.008	0.540 + 0.008	0.040	0.030	0.59
5/8 in.	0.04 + 0.01	4	0.071 ± 0.010	0.86	0.51	0.630 + 0.008	0.670 + 0.008	0.045	0.030	0.59
3/4 in.	0.04 + 0.01	5	0.102 ± 0.010	1.00	0.59	0.730 + 0.008	0.780 + 0.008	0.050	0.035	0.83
1 in.	0.04 + 0.01	5	0.126 ± 0.010	1.40	0.77	0.900 + 0.008	0.950 + 0.008	0.055	0.035	0.94
Metric	millimeters		B	C	D	E	F	G	EW	L
Size	A	Number	Gap	Stop	Inside	Insert	Rib	Minimum	EX	
STD (nom)	Rib	of Ribs	Width	Dia. min	Dia. min	Diameter	Diameter	Wall	Depth	
	Width		Typ							
	Typ									
3/8 in. (10 mm)	(1 ± 0.25)	4	(1.8 ± 0.25)	(16)	(7.70)	(9.5 + 0.2)	(10.3 + 0.2)	(0.63)	(0.50)	(15)
1/2 in. (13 mm)	(1 ± 0.25)	4	(1.8 ± 0.25)	(20)	(10.3)	(13.0 + 0.2)	(13.8 + 0.2)	(1.0)	(0.80)	(15)
5/8 in. (16 mm)	(1 ± 0.25)	4	(1.8 ± 0.25)	(22)	(12.9)	(16.0 + 0.2)	(17.0 + 0.2)	(1.14)	(0.80)	(15)
3/4 in. (19 mm)	(1 ± 0.25)	5	(2.6 ± 0.25)	(27)	(15.0)	(18.6 + 0.2)	(19.8 + 0.2)	(1.27)	(0.89)	(21)
1 in. (25 mm)	(1 ± 0.25)	5	(3.2 ± 0.25)	(34)	(19.5)	(22.9 + 0.2)	(24.0 + 0.2)	(1.40)	(0.89)	(24)

FIG. 1 Mechanical Insert Dimensions and Tolerances