



Designation: C 831 – 98

## Standard Test Methods for Residual Carbon, Apparent Residual Carbon, and Apparent Carbon Yield in Coked Carbon-Containing Brick and Shapes <sup>1</sup>

This standard is issued under the fixed designation C 831; the number immediately following the designation indicates the year of original adoption or, in the case of revision, the year of last revision. A number in parentheses indicates the year of last reapproval. A superscript epsilon ( $\epsilon$ ) indicates an editorial change since the last revision or reapproval.

### 1. Scope

1.1 These test methods cover the determination of residual carbon content in carbon-bearing brick and shapes after a prescribed coking treatment. They provide two procedures. The first procedure is based on the combustion of carbon and its measurement as carbon dioxide. However, when using the first procedure for articles that contain silicon carbide or other carbides, no distinction will be made between carbon present in the form of a carbide and carbon present as elemental carbon. The second procedure provides a method for calculating apparent residual carbon (on the basis of weight loss after igniting the coked specimens), apparent carbonaceous material content, and apparent carbon yield. If the second procedure is used for brick or shapes that contain metallic additives or carbides, it must be recognized that there will be a weight gain associated with the oxidation of the metals, or carbides, or both. Such a weight gain can change the results substantially and this must be kept in mind when interpreting the data.

1.2 The values stated in inch-pound units are to be regarded as the standard. The values given in parentheses are for information only.

1.3 *This standard does not purport to address all of the safety concerns, if any, associated with its use. It is the responsibility of the user of this standard to establish appropriate safety and health practices and determine the applicability of regulatory limitations prior to use.*

### 2. Referenced Documents

#### 2.1 ASTM Standards:

C 571 Methods for Chemical Analysis of Carbon and Carbon-Ceramic Refractories <sup>2</sup>

D 2906 Practice for Statements on Precision and Bias for Textiles <sup>3</sup>

<sup>1</sup> These test methods are under the jurisdiction of ASTM Committee C-8 on Refractories and are the direct responsibility of Subcommittee C08.04 on Chemical Behaviors.

Current edition approved March 10, 1998. Published December 1998. Originally published as C 831 – 76. Last previous edition C 831 – 97.

<sup>2</sup> Discontinued. See 1996 Annual Book of ASTM Standards, Vol 03.05

<sup>3</sup> Annual Book of ASTM Standards, Vol 07.01

E 11 Specification for Wire-Cloth Sieves for Testing Purposes <sup>4</sup>

### 3. Significance and Use

3.1 These test methods are designed for use with carbon-containing products. The residual carbon content of a coked carbon containing brick or shape is an indication of how much carbon may be available, in service, to resist slag attack on, or oxidation loss of, that body. Apparent carbon yield gives an estimate of the relative efficiency of the total carbonaceous matter to be retained as residual carbon.

3.2 Residual carbon has a direct bearing on several properties of a pitch or resin containing refractory such as ignited porosity, density, strength, and thermal conductivity.

3.3 These test methods are suitable for product development, manufacturing control and specification acceptance.

3.4 These test methods are very sensitive to specimen size, coking rates, etc., therefore, strict compliance with these test methods is critical.

3.5 Appreciable amounts of reducible components, such as  $\text{Fe}_2\text{O}_3$ , will have a noticeable effect on the results. Thus, values obtained by these test methods will be different when brick removed from service is tested. This must be kept in mind when attempting to use these test methods in an absolute sense.

3.6 Oxidizable components such as metals and carbides can have a noticeable effect on the results. This must be kept in mind when using the second procedure, which is based on measuring weight loss after igniting the coked specimens.

3.7 Testing of brick or shapes that contain magnesium metal presents special problems since this metal is highly volatile and substantial amounts of the magnesium can be lost from the sample during the coking procedure. This must be kept in mind when interpreting the results of testing of brick that contain magnesium. In addition, magnesium can react readily with atmospheric humidity. This must be kept in mind when storing brick that contain magnesium.

<sup>4</sup> Annual Book of ASTM Standards, Vol 14.02.

**4. Apparatus**

4.1 For Coking:

4.1.1 Gas or Electric Furnace with heating chamber capable of receiving the coking box shown in Fig. 1.

NOTE 1—Samples should not be subjected to thermal gradients greater than 40°F (22°C) during heatup. In electric furnaces with silicon carbide heating elements, the length of the box should be parallel to these elements.

4.1.2 Inner and Outer Box, stainless steel (or equivalent alloy), as shown in Figs. 1-3.

4.2 For CO<sub>2</sub> Absorption:

4.2.1 Laboratory Pulverizer<sup>5</sup> designed to provide a sealed, dustproof grinding chamber, and having a capacity of at least 50 g of sample.

4.2.2 Combustion-Tube Furnace capable of operating at 183°F (1000°C)

4.2.3 CO<sub>2</sub>-Absorption Train as described in Fig. 4 and in Method C 571

NOTE 2—Commercial automatic and semi-automatic carbon determinators may replace the apparatus described in 4.2.2 and 4.2.3.

4.3 The precision obtained with these instruments shall meet the requirements specified in Section 10.

**5. Preparation of Test Specimens**

5.1 This method assumes that the number of specimens tested will be a statistically valid sample of the entire lot of brick or shapes being evaluated. The exact number is usually arrived at by mutual agreement between parties concerned.

5.2 Although sample brick from either the 4½-in. (114-mm) or the 6-in. (152-mm) series may be tested, it is preferable to use the larger size for the test. Cut slices 1 ± 1/32 in. (25 ± 0.8 mm) in thickness perpendicular to the length at the mid-section of each sample brick or shape. As shown in Fig. 5, the nominal

<sup>5</sup> Typical grinders are: Blueier Mill, Applied Research Laboratories, Sunland, CA; Laboratory Disc Mill, Angstrom, Inc., Bellville, MI; and Shatter Box, Spex Industries, Inc., Metuchen, NJ.

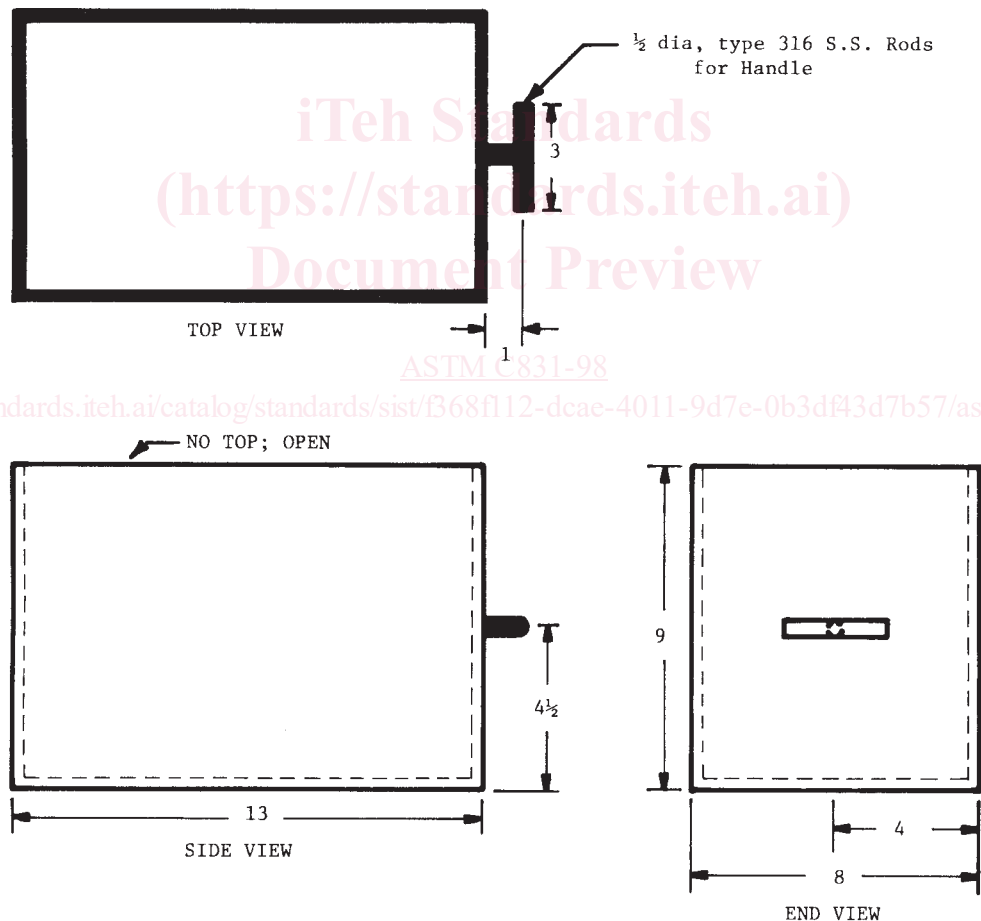

NOTE 1—Material specified is type 316 stainless steel (S.S.) or other suitable alloy (1/4 in. (6 mm) recommended).  
 NOTE 2—All dimensions minimum outside diameter.

	Metric Equivalents							
in.	1/2	1	3	4	4 1/2	8	9	13
mm	13	25	76	102	114	203	229	330

**FIG. 1 Outer Coking Box (Dimensions are in Inches)**

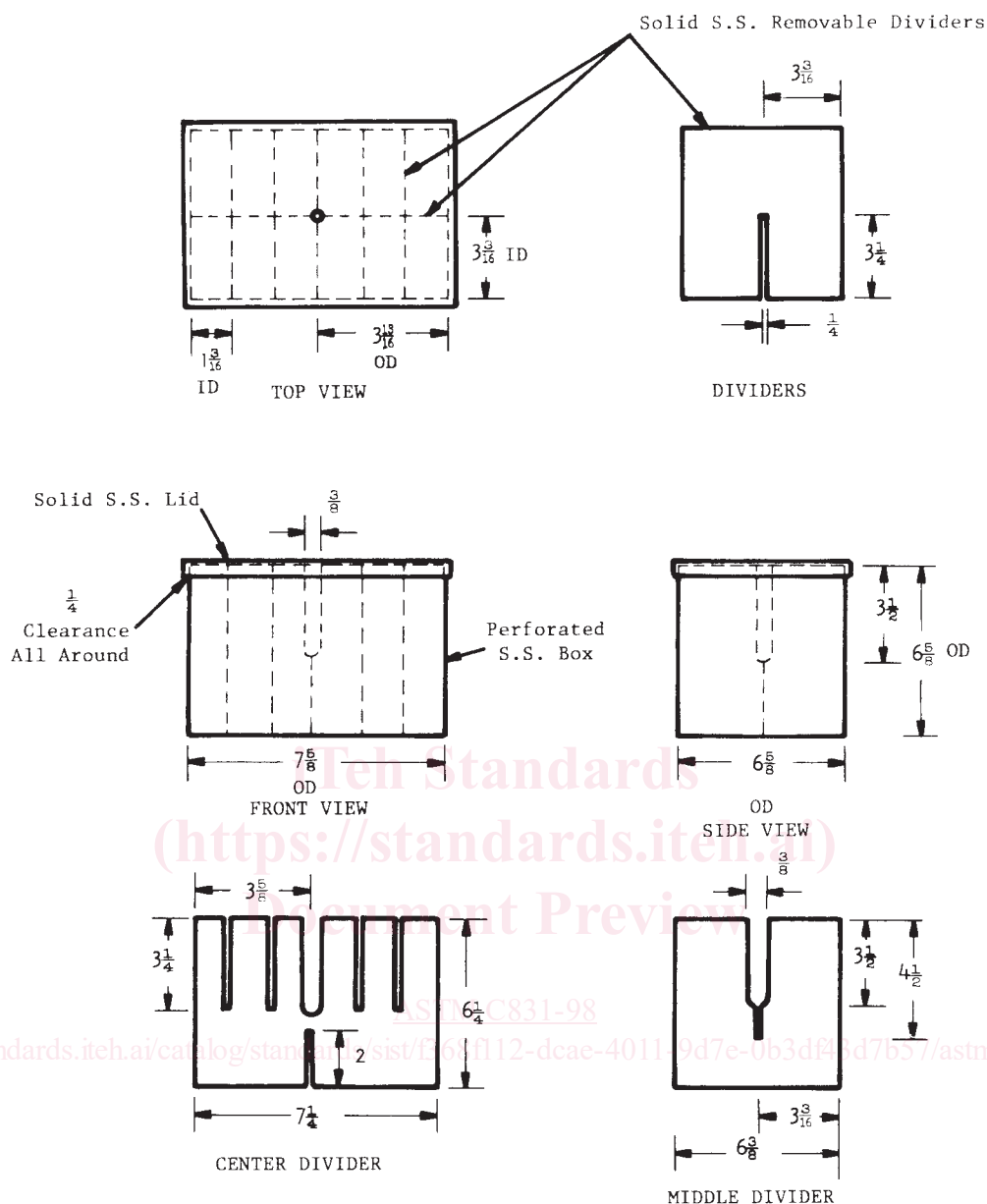

NOTE 1—Type 316 stainless steel (S.S.) or other suitable alloy, 14 gage (1.984 mm). Perforated S.S.: 14 gage.  $\frac{3}{16}$ -in. (5-mm) diameter perforations,  $\frac{1}{2}$ -in. (13-mm) centers, 11 % open.

NOTE 2—Dimensions are in inches.

Metric Equivalents

in.	$\frac{1}{4}$	$\frac{3}{8}$	$1\frac{1}{16}$	2	$3\frac{3}{16}$	$3\frac{1}{4}$	$3\frac{1}{2}$	$3\frac{5}{8}$	$3\frac{13}{16}$	$4\frac{1}{2}$	$6\frac{1}{4}$	$6\frac{3}{8}$	$6\frac{5}{8}$	$7\frac{1}{4}$	$7\frac{5}{8}$
mm	6	10	30	51	81	83	89	92	97	114	159	162	168	184	194

**FIG. 2 Inner Coking Box**

size of each slice shall be 1 by 3 by 6 in. (25 by 76 by 152 mm). The two 1 by 3-in. faces and the two 1 by 6-in. faces must be original surfaces.

5.3 Test specimens may be cut wet or dry except for products capable of hydration, such as dolomite brick, which must be cut dry and stored in a dry container prior to coking.

5.4 Specimens that are cut wet must be dried immediately with a paper or cloth towel and flash dried. For pitch-

impregnated samples, flash drying should be done at a sufficiently low temperature to avoid “weeping” of pitch from the pores of the brick. Drying can usually be done on a forced-air dryer at 220°F (105°C) by limiting exposure to 5 to 10 min. Repeat if necessary. These drying procedures are especially important for metal-containing brick because hydration of the metals can occur. Specimens containing a coating of pitch on