

# INTERNATIONAL STANDARD



**Primary batteries –  
Part 1: General**

iTech Standards  
(<https://standards.iteh.ai>)  
Document Preview

IEC 60086-1:2015

<https://standards.iteh.ai/catalog/standards/iec/60086-1-2015>

Withhold



## THIS PUBLICATION IS COPYRIGHT PROTECTED

Copyright © 2015 IEC, Geneva, Switzerland

All rights reserved. Unless otherwise specified, no part of this publication may be reproduced or utilized in any form or by any means, electronic or mechanical, including photocopying and microfilm, without permission in writing from either IEC or IEC's member National Committee in the country of the requester. If you have any questions about IEC copyright or have an enquiry about obtaining additional rights to this publication, please contact the address below or your local IEC member National Committee for further information.

IEC Central Office  
3, rue de Varembe  
CH-1211 Geneva 20  
Switzerland

Tel.: +41 22 919 02 11  
Fax: +41 22 919 03 00  
[info@iec.ch](mailto:info@iec.ch)  
[www.iec.ch](http://www.iec.ch)

### About the IEC

The International Electrotechnical Commission (IEC) is the leading global organization that prepares and publishes International Standards for all electrical, electronic and related technologies.

### About IEC publications

The technical content of IEC publications is kept under constant review by the IEC. Please make sure that you have the latest edition, a corrigenda or an amendment might have been published.

#### IEC Catalogue - [webstore.iec.ch/catalogue](http://webstore.iec.ch/catalogue)

The stand-alone application for consulting the entire bibliographical information on IEC International Standards, Technical Specifications, Technical Reports and other documents. Available for PC, Mac OS, Android Tablets and iPad.

#### IEC publications search - [www.iec.ch/searchpub](http://www.iec.ch/searchpub)

The advanced search enables to find IEC publications by a variety of criteria (reference number, text, technical committee,...). It also gives information on projects, replaced and withdrawn publications.

#### IEC Just Published - [webstore.iec.ch/justpublished](http://webstore.iec.ch/justpublished)

Stay up to date on all new IEC publications. Just Published details all new publications released. Available online and also once a month by email.

#### Electropedia - [www.electropedia.org](http://www.electropedia.org)

The world's leading online dictionary of electronic and electrical terms containing more than 30 000 terms and definitions in English and French, with equivalent terms in 15 additional languages. Also known as the International Electrotechnical Vocabulary (IEV) online.

#### IEC Glossary - [std.iec.ch/glossary](http://std.iec.ch/glossary)

More than 60 000 electrotechnical terminology entries in English and French extracted from the Terms and Definitions clause of IEC publications issued since 2002. Some entries have been collected from earlier publications of IEC TC 37, 77, 86 and CISPR.

#### IEC Customer Service Centre - [webstore.iec.ch/csc](http://webstore.iec.ch/csc)

If you wish to give us your feedback on this publication or need further assistance, please contact the Customer Service Centre: [csc@iec.ch](mailto:csc@iec.ch).

IEC 60086-1:2015

<https://standards.iteh.ai/catalog/standards/iec/b5309a0c3-013d-4de5-91d4-21149059e98f/iec-60086-1-2015>



IEC 60086-1

Edition 12.0 2015-07  
REDLINE VERSION

# INTERNATIONAL STANDARD



Primary batteries –  
Part 1: General

iTech Standards  
(<https://standards.itih.ai>)  
Document Preview

IEC 60086-1:2015

<https://standards.itih.ai/standards/iec/60086-1-2015>

INTERNATIONAL  
ELECTROTECHNICAL  
COMMISSION

ICS 29.220.10

ISBN 978-2-8322-2825-8

**Warning! Make sure that you obtained this publication from an authorized distributor.**

## CONTENTS

FOREWORD.....	5
INTRODUCTION.....	2
1 Scope.....	8
2 Normative references .....	8
3 Terms and definitions .....	8
4 Requirements .....	11
4.1 General.....	11
4.1.1 Design .....	11
4.1.2 Battery dimensions .....	12
4.1.3 Terminals .....	12
4.1.4 Classification (electrochemical system) .....	14
4.1.5 Designation .....	15
4.1.6 Marking .....	15
4.1.7 Interchangeability: battery voltage .....	16
4.2 Performance .....	17
4.2.1 Discharge performance.....	17
4.2.2 Dimensional stability.....	17
4.2.3 Leakage .....	17
4.2.4 Open-circuit voltage limits.....	17
4.2.5 Service output .....	18
4.2.6 Safety.....	18
5 Performance – Testing .....	18
5.1 General.....	18
5.2 Discharge testing.....	18
5.2.1 General.....	18
5.2.2 Application tests .....	19
5.2.3 Service output tests .....	19
5.3 Conformance check to a specified minimum average duration .....	20
5.4 Calculation method of the specified value of a minimum average duration .....	20
5.5 OCV testing.....	20
5.6 Battery dimensions .....	20
5.7 Leakage and deformation.....	20
6 Performance – Test conditions .....	20
6.1 <del>Pre-discharge conditioning</del> Storage and discharge conditions .....	20
6.2 Commencement of discharge tests after storage.....	21
6.3 Discharge test conditions .....	21
6.3.1 General .....	21
6.3.2 Compliance .....	21
6.4 Load resistance .....	21
6.5 Time periods.....	22
6.6 Test condition tolerances .....	22
6.7 Activation of ‘P’-system batteries .....	22
6.8 Measuring equipment.....	22
6.8.1 Voltage measurement.....	22
6.8.2 Mechanical measurement.....	23

7	Sampling and quality assurance .....	23
7.1	<del>General</del> .....	
7.2	<del>Sampling</del> .....	
7.2.1	<del>Testing by attributes</del> .....	
7.2.2	<del>Testing by variables</del> .....	
7.3	<del>Product quality indices</del> .....	
7.3.1	<del>General</del> .....	
7.3.2	<del>Capability index (<math>c_p</math>)</del> .....	
7.3.3	<del>Capability index (<math>c_{pk}</math>)</del> .....	
7.3.4	<del>Performance index (<math>p_p</math>)</del> .....	
7.3.5	<del>Performance index (<math>p_{pk}</math>)</del> .....	
8	Battery packaging .....	24
Annex A (normative)	<del>Guidelines</del> <del>Criteria</del> for the standardization of batteries .....	25
Annex B (normative informative)	<del>Recommendations</del> for equipment design .....	26
B.1	Technical liaison .....	26
B.2	Battery compartment .....	26
B.2.1	<del>General</del> .....	26
B.2.2	<del>Limiting access by children</del> .....	27
B.3	Voltage cut-off .....	27
Annex C (normative)	Designation system (nomenclature) .....	28
C.1	<del>General</del> .....	28
C.2	Designation system in use up to October 1990 .....	28
C.2.1	General .....	28
C.2.2	Cells .....	28
C.2.3	Electrochemical system .....	30
C.2.4	Batteries .....	31
C.2.5	Modifiers .....	31
C.2.6	Examples .....	31
C.3	Designation system in use since October 1990 .....	31
C.3.1	General .....	31
C.3.2	Round batteries .....	31
C.3.3	Non-round batteries .....	35
C.3.4	Ambiguity .....	38
Annex D (informative)	Standard discharge voltage $U_S$ – Definition and method of determination .....	40
D.1	Definition .....	40
D.2	Determination .....	40
D.2.1	General considerations: the $C/R$ -plot .....	40
D.2.2	Determination of the standard discharge resistor $R_S$ .....	41
D.2.3	Determination of the standard discharge capacity $C_S$ and standard discharge time $t_S$ .....	42
D.3	Experimental conditions to be observed and test results .....	42
Annex E (informative)	Preparation of standard methods of measuring performance (SMMP) of consumer goods .....	44
E.1	<del>Overview</del> <del>General</del> .....	44
E.2	Performance characteristics .....	44
E.3	Criteria for the development of test methods .....	44
Annex F (informative)	Calculation method for the specified value of minimum average duration .....	45

Annex G (normative) Code of practice for packaging, shipment, storage, use and disposal of primary batteries .....	46
G.1 General.....	46
G.2 Packaging.....	46
G.3 Transport and handling .....	46
G.4 Storage and stock rotation .....	46
G.5 Displays at sales points .....	47
G.6 Selection, use and disposal .....	47
G.6.1 Purchase .....	47
G.6.2 Installation.....	47
G.6.3 Use.....	47
G.6.4 Replacement .....	48
G.6.5 Disposal .....	48
Bibliography.....	49
Figure 1 – <del>Small cell or battery gauge (inner dimensions)</del> Ingestion gauge .....	11
Figure 2 – <del>Stud</del> .....	
Figure C.1 – Designation system for round batteries: $d_1 < 100$ mm; height $h_1 < 100$ mm .....	32
Figure C.2 – Diameter code for non-recommended diameters.....	33
Figure C.3 – Height code for denoting the hundredths of a millimetre of height .....	34
Figure C.4 – Designation system for round batteries: $d_1 \geq 100$ mm; height $h_1 \geq 100$ mm .....	35
Figure C.5 – Designation system for non-round batteries, dimensions $< 100$ mm .....	36
Figure C.6 – Designation system for non-round batteries, dimensions $\geq 100$ mm .....	37
Figure C.7 – Height code for discrimination per tenth of a millimetre .....	38
Figure D.1 – Normalized C/R-plot (schematic).....	41
Figure D.2 – Standard discharge voltage (schematic) .....	42
Table 1 – <del>Spacing of contacts</del> .....	
Table 2 – <del>Snap fastener connectors</del> .....	
Table 1 – Standardized electrochemical systems .....	15
Table 2 – Marking requirements.....	16
Table 3 – Conditions for storage before and during discharge testing .....	21
Table 4 – Resistive loads for new tests .....	22
Table 5 – Time periods for new tests .....	22
Table 6 – Test condition tolerances .....	22
Table A.1 – Items necessary to standardize.....	25
Table C.1 – Physical designation and dimensions of round cells and batteries.....	29
Table C.2 – Physical designation and nominal overall dimensions of flat cells .....	30
Table C.3 – Physical designation and dimensions of square cells and batteries .....	30
Table C.4 – Diameter code for recommended diameter.....	33
Table C.5 – Physical designation and dimensions of round cells and batteries based on Clause C.2.....	39
Table C.6 – Physical designation and dimensions of non-round batteries based on Clause C.2.....	39
Table D.1 – Standard discharge voltage by system.....	43

## INTERNATIONAL ELECTROTECHNICAL COMMISSION

## PRIMARY BATTERIES –

## Part 1: General

## FOREWORD

- 1) The International Electrotechnical Commission (IEC) is a worldwide organization for standardization comprising all national electrotechnical committees (IEC National Committees). The object of IEC is to promote international co-operation on all questions concerning standardization in the electrical and electronic fields. To this end and in addition to other activities, IEC publishes International Standards, Technical Specifications, Technical Reports, Publicly Available Specifications (PAS) and Guides (hereafter referred to as “IEC Publication(s)”). Their preparation is entrusted to technical committees; any IEC National Committee interested in the subject dealt with may participate in this preparatory work. International, governmental and non-governmental organizations liaising with the IEC also participate in this preparation. IEC collaborates closely with the International Organization for Standardization (ISO) in accordance with conditions determined by agreement between the two organizations.
- 2) The formal decisions or agreements of IEC on technical matters express, as nearly as possible, an international consensus of opinion on the relevant subjects since each technical committee has representation from all interested IEC National Committees.
- 3) IEC Publications have the form of recommendations for international use and are accepted by IEC National Committees in that sense. While all reasonable efforts are made to ensure that the technical content of IEC Publications is accurate, IEC cannot be held responsible for the way in which they are used or for any misinterpretation by any end user.
- 4) In order to promote international uniformity, IEC National Committees undertake to apply IEC Publications transparently to the maximum extent possible in their national and regional publications. Any divergence between any IEC Publication and the corresponding national or regional publication shall be clearly indicated in the latter.
- 5) IEC itself does not provide any attestation of conformity. Independent certification bodies provide conformity assessment services and, in some areas, access to IEC marks of conformity. IEC is not responsible for any services carried out by independent certification bodies.
- 6) All users should ensure that they have the latest edition of this publication.
- 7) No liability shall attach to IEC or its directors, employees, servants or agents including individual experts and members of its technical committees and IEC National Committees for any personal injury, property damage or other damage of any nature whatsoever, whether direct or indirect, or for costs (including legal fees) and expenses arising out of the publication, use of, or reliance upon, this IEC Publication or any other IEC Publications.
- 8) Attention is drawn to the Normative references cited in this publication. Use of the referenced publications is indispensable for the correct application of this publication.
- 9) Attention is drawn to the possibility that some of the elements of this IEC Publication may be the subject of patent rights. IEC shall not be held responsible for identifying any or all such patent rights.

**This redline version of the official IEC Standard allows the user to identify the changes made to the previous edition. A vertical bar appears in the margin wherever a change has been made. Additions are in green text, deletions are in strikethrough red text.**

International Standard IEC 60086-1 has been prepared by IEC technical committee 35: Primary cells and batteries.

This twelfth edition cancels and replaces the eleventh edition (2011) and constitutes a technical revision.

The major technical changes with respect to the previous edition are:

- the order of the Annexes was changed to the order in which they appear in the document and a caption was added to indicate where the Annex information first appears in the document;
- the humidity conditions for non P-system batteries in Table 3 was modified;
- the standard discharge voltage for the Y and W chemistries was determined to be at 3,5 V and 2,8 V respectively;
- details on capacity measurement were moved from Annex E to Subclause 5.1.
- the coin/button cell and battery definition was clarified in order to better address issues with the swallowing of coin cells.

The text of this standard is based on the following documents:

FDIS	Report on voting
35/1346/FDIS	35/1349/RVD

Full information on the voting for the approval of this standard can be found in the report on voting indicated in the above table.

This publication has been drafted in accordance with the ISO/IEC Directives, Part 2.

A list of all parts in the IEC 60086 series, under the general title *Primary batteries*, can be found on the IEC website.

The committee has decided that the contents of this publication will remain unchanged until the stability date indicated on the IEC website under "<http://webstore.iec.ch>" in the data related to the specific publication. At this date, the publication will be

- reconfirmed,
- withdrawn,
- replaced by a revised edition, or
- amended.

A bilingual version of this publication may be issued at a later date.

**IMPORTANT – The “colour inside” logo on the cover page of this publication indicates that it contains colours which are considered to be useful for the correct understanding of its contents. Users should therefore print this publication using a colour printer.**



## INTRODUCTION

The technical content of this part of IEC 60086 provides fundamental requirements and information on primary cells and batteries. All batteries within the IEC 60086 series are considered dry cell batteries. In this sense, IEC 60086-1 is the main component of the IEC 60086 series and forms the basis for the subsequent parts. For example, this part includes elementary information on definitions, nomenclature, dimensions and marking. While specific requirements are included, the content of this part tends to explain methodology (how) and justification (why).

Over the years, this part has been changed to improve its content and remains under continual scrutiny to ensure that the publication is kept up to date with the advances in both battery and battery-powered device technologies.

NOTE Safety information is available in IEC 60086-4, IEC 60086-5 and IEC 62281.

Witholdam

iTech Standards  
(<https://standards.itih.ai>)  
Document Preview

<https://standards.itih.ai/standards/iec/60086-1-2015>

<https://standards.itih.ai/standards/iec/60086-1-2015>

# PRIMARY BATTERIES –

## Part 1: General

### 1 Scope

This part of IEC 60086 is intended to standardize primary batteries with respect to dimensions, nomenclature, terminal configurations, markings, test methods, typical performance, safety and environmental aspects.

As a primary battery classification tool, electrochemical systems are also standardized with respect to system letter, electrodes, electrolyte, nominal and maximum open circuit voltage.

NOTE The requirements justifying the inclusion or the ongoing retention of batteries in the IEC 60086 series are given in Annex A.

The object of this part of IEC 60086 is to benefit primary battery users, device designers and battery manufacturers by ensuring that batteries from different manufacturers are interchangeable according to standard form, fit and function. Furthermore, to ensure compliance with the above, this part specifies standard test methods for testing primary cells and batteries.

### 2 Normative references

The following documents, in whole or in part, are normatively referenced in this document and are indispensable for its application. For dated references, only the edition cited applies. For undated references, the latest edition of the referenced document (including any amendments) applies.

IEC 60086-2:~~2011~~<sup>1</sup>, *Primary batteries – Part 2: Physical and electrical specifications*

IEC 60086-3:2011, *Primary batteries – Part 3: Watch batteries*

IEC 60086-4:~~2007~~<sup>2014</sup>, *Primary batteries – Part 4: Safety of lithium batteries*

IEC 60086-5:2011, *Primary batteries – Part 5: Safety of batteries with aqueous electrolyte*

~~IEC 60410, *Sampling plans and procedures for inspection by attributes*~~

~~ISO/IEC Directives, Part 1: *Procedures for the technical work*~~

~~ISO 3951(all parts, as applicable), *Sampling procedures*~~

### 3 Terms and definitions

For the purposes of this document, the following terms and definitions apply.

---

<sup>1</sup> To be published.

### 3.1

#### **application test**

simulation of the actual use of a battery in a specific application

### 3.2

#### **battery**

one or more cells electrically connected ~~by permanent means, and~~ fitted in a case, with terminals, markings and protective devices etc., as necessary for use

[SOURCE:IEC 60050-482:2004, 482-01-04, modified definition]

### 3.3

#### **button (cell or battery)**

small round cell or battery where the overall height is less than the diameter; ~~batteries complying with Figures 3 and 4 of IEC 60086-2~~

Note 1 to entry: In English, the term "button (cell or battery)" is only used for non-lithium batteries while the term "coin (cell or battery)" is used for lithium batteries only. In languages other than English, the terms "coin" and "button" are often used interchangeably, regardless of the electrochemical system.

### 3.4

#### **cell**

basic functional unit, consisting of an assembly of electrodes, electrolyte, container, terminals and usually separators, that is a source of electric energy obtained by direct conversion of chemical energy

[SOURCE:IEC 60050-482:2004, 482-01-01]

### 3.5

#### **closed-circuit voltage**

#### **CCV** (abbreviation)

voltage across the terminals of a battery when it is on discharge

[SOURCE:IEC 60050-482:2004, 482-03-28, modified ("voltage between the terminals of a cell or battery" replaced by "voltage across the terminals of a battery")]

### 3.6

#### **coin (cell or battery)**

see button (cell or battery)

### 3.7

#### **cylindrical (cell or battery)**

~~round~~ cell or battery ~~with a cylindrical shape~~ in which the overall height is equal to or greater than the diameter

[SOURCE:IEC 60050-482: 2004, 482-02-39, modified ("cell with a cylindrical shape" replaced by "round cell or battery")]

### 3.8

#### **discharge** (of a primary battery)

operation during which a battery delivers current to an external circuit

~~[IEC 60050-482:2004, 482-03-23, modified]~~

### 3.9

#### **dry (primary) battery**

primary battery in which the liquid electrolyte is essentially immobilized

[SOURCE:IEC 60050-482:2004, 482-04-14, modified]

**3.10**  
**effective internal resistance – DC method**

the internal d.c. resistance of any electrochemical cell is defined by the following relation:

$$R_i (\Omega) = \frac{\Delta U (V)}{\Delta i (A)}$$

**3.11**  
**end-point voltage**

**EV** (abbreviation)

specified voltage of a battery at which the battery discharge is terminated

[SOURCE:IEC 60050-482:2004, 482-03-30, ~~modified~~]

**3.12**  
**leakage**

unplanned escape of electrolyte, gas or other material from a cell or battery

[SOURCE:IEC 60050-482:2004, 482-02-32]

**3.13**  
**minimum average duration**

**MAD** (abbreviation)

minimum average time on discharge which is met by a sample of batteries

Note 1 to entry: The discharge test is carried out according to the specified methods or standards and designed to show conformity with the standard applicable to the battery types.

**3.14**  
**nominal voltage** (of a primary battery)

$V_n$  (symbol)

suitable approximate value of the voltage used to designate or identify a cell, a battery or an electrochemical system

[SOURCE:IEC 60050-482:2004, 482-03-31, modified (addition of "(of a primary battery)" and symbol  $V_n$ )]

**3.15**  
**open-circuit voltage**

**OCV** (abbreviation)

voltage across the terminals of a cell or battery when it is off discharge

~~[IEC 60050-482:2004, 482-03-32, modified]~~

**3.16**  
**primary** (cell or battery)

cell or battery that is not designed to be electrically recharged

**3.17**  
**round** (cell or battery)

cell or battery with circular cross section

**3.18**  
**service output** (of a primary battery)

service life, or capacity, or energy output of a battery under specified conditions of discharge

**3.19****service output test**

test designed to measure the service output of a battery

Note 1 to entry: A service output test may be prescribed, for example, when

- a) an application test is too complex to replicate;
- b) the duration of an application test would make it impractical for routine testing purposes.

**3.20****small battery**

cell or battery fitting **entirely** within the limits of the truncated cylinder as defined in Figure 1

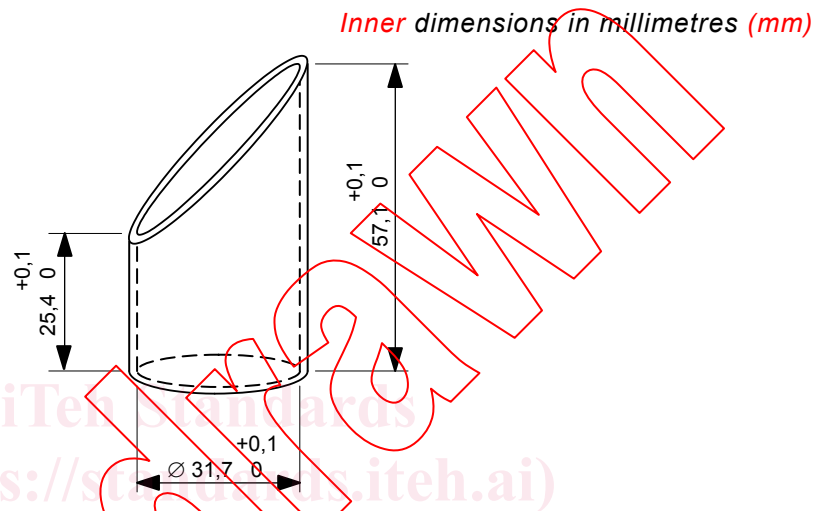

**Figure 1 – ~~Small cell or battery gauge (inner dimensions)~~ Ingestion gauge**

**3.21****storage life**

duration under specified conditions at the end of which a battery retains its ability to perform a specified service output

[SOURCE:IEC 60050-482:2004, 482-03-47, modified ("function" replaced by "service output")]

**3.22****terminals** (of a primary battery)

conductive parts ~~provided for the connection~~ of a battery that provide connection to an external ~~conductors circuit~~

**4 Requirements****4.1 General****4.1.1 Design**

Primary batteries are sold mainly in consumer markets. In recent years, they have become more sophisticated in both chemistry and construction, for example both capacity and rate capability have increased to meet the growing demands from new, battery-powered equipment technology.

When designing primary batteries, the aforementioned considerations shall be taken into account. Specifically, their dimensional conformity and stability, their physical and electrical performance and their safe operation under normal use and foreseeable mis-use conditions shall be assured.

Additional information on equipment design can be found in Annex B.

#### 4.1.2 Battery dimensions

The dimensions for individual types of batteries are given in IEC 60086-2 and IEC 60086-3.

#### 4.1.3 Terminals

##### 4.1.3.1 General

Terminals shall be in accordance with Clause 6 of IEC 60086-2:-.

Their physical shape shall be designed in such a way that they ensure that the batteries make and maintain good electrical contact at all times.

They shall be made of materials that provide ~~adequate~~ good electrical conductivity and ~~resistance to corrosion~~ protection.

##### 4.1.3.2 Contact pressure resistance

Where stated in the battery specification tables or the individual specification sheets in IEC 60086-2, the following applies:

- a force of 10 N applied through a steel ball of 1 mm diameter at the centre of each contact area for a period of 10 s shall not cause any apparent deformation which might prevent satisfactory operation of the battery.

NOTE See also IEC 60086-3 for exceptions.

##### 4.1.3.3 Cap and base

This type of terminal is used for batteries which have their dimensions specified according to Figures 1 ~~and 2~~ to 7 of IEC 60086-2:- and which have the cylindrical side of the battery insulated from the terminals.

##### 4.1.3.4 Cap and case

This type of terminal is used for batteries which have their dimensions specified according to Figures ~~3 and 4~~ 8, 9, 10, 14, 15 and 16 of IEC 60086-2:-, but in which the cylindrical side of the battery forms part of the positive terminal.

##### 4.1.3.5 Screw terminals

This contact consists of a threaded rod in combination with either a metal or insulated metal nut.

##### 4.1.3.6 Flat contacts

These are essentially flat metal surfaces adapted to make electrical contact by suitable contact mechanisms bearing against them.

##### 4.1.3.7 Flat or spiral springs

These contacts comprise flat metal strips or spirally wound wires which are in a form that provides pressure contact.

##### 4.1.3.8 Plug-in-sockets

These are made up of a suitable assembly of metal contacts, mounted in an insulated housing or holding device and adapted to receive corresponding pins of a mating plug.