

INTERNATIONAL STANDARD

NORME INTERNATIONALE

Primary batteries – **STANDARD PREVIEW**
Part 3: Watch batteries
(standards.iteh.ai)

Piles électriques –
Partie 3: Piles pour montres
<https://standards.iteh.ai/catalog/standards/sist/81a9957f-44d3-4efa-99ba-9a05894ad460/iec-60086-3-2016>



THIS PUBLICATION IS COPYRIGHT PROTECTED
Copyright © 2016 IEC, Geneva, Switzerland

All rights reserved. Unless otherwise specified, no part of this publication may be reproduced or utilized in any form or by any means, electronic or mechanical, including photocopying and microfilm, without permission in writing from either IEC or IEC's member National Committee in the country of the requester. If you have any questions about IEC copyright or have an enquiry about obtaining additional rights to this publication, please contact the address below or your local IEC member National Committee for further information.

Droits de reproduction réservés. Sauf indication contraire, aucune partie de cette publication ne peut être reproduite ni utilisée sous quelque forme que ce soit et par aucun procédé, électronique ou mécanique, y compris la photocopie et les microfilms, sans l'accord écrit de l'IEC ou du Comité national de l'IEC du pays du demandeur. Si vous avez des questions sur le copyright de l'IEC ou si vous désirez obtenir des droits supplémentaires sur cette publication, utilisez les coordonnées ci-après ou contactez le Comité national de l'IEC de votre pays de résidence.

IEC Central Office
3, rue de Varembe
CH-1211 Geneva 20
Switzerland

Tel.: +41 22 919 02 11
Fax: +41 22 919 03 00
info@iec.ch
www.iec.ch

About the IEC

The International Electrotechnical Commission (IEC) is the leading global organization that prepares and publishes International Standards for all electrical, electronic and related technologies.

About IEC publications

The technical content of IEC publications is kept under constant review by the IEC. Please make sure that you have the latest edition, a corrigenda or an amendment might have been published.

IEC Catalogue - webstore.iec.ch/catalogue

The stand-alone application for consulting the entire bibliographical information on IEC International Standards, Technical Specifications, Technical Reports and other documents. Available for PC, Mac OS, Android Tablets and iPad.

IEC publications search - www.iec.ch/searchpub

The advanced search enables to find IEC publications by a variety of criteria (reference number, text, technical committee,...). It also gives information on projects, replaced and withdrawn publications.

IEC Just Published - webstore.iec.ch/justpublished

Stay up to date on all new IEC publications. Just Published details all new publications released. Available online and also once a month by email.

Electropedia - www.electropedia.org

The world's leading online dictionary of electronic and electrical terms containing 20 000 terms and definitions in English and French, with equivalent terms in 15 additional languages. Also known as the International Electrotechnical Vocabulary (IEV) online.

IEC Glossary - std.iec.ch/glossary

65 000 electrotechnical terminology entries in English and French extracted from the Terms and Definitions clause of IEC publications issued since 2002. Some entries have been collected from earlier publications of IEC TC 37, 77, 86 and CISPR.

IEC Customer Service Centre - webstore.iec.ch/csc

If you wish to give us your feedback on this publication or need further assistance, please contact the Customer Service Centre: csc@iec.ch.

A propos de l'IEC

La Commission Electrotechnique Internationale (IEC) est la première organisation mondiale qui élabore et publie des Normes internationales pour tout ce qui a trait à l'électricité, à l'électronique et aux technologies apparentées.

A propos des publications IEC

Le contenu technique des publications IEC est constamment revu. Veuillez vous assurer que vous possédez l'édition la plus récente, un corrigendum ou amendement peut avoir été publié.

Catalogue IEC - webstore.iec.ch/catalogue

Application autonome pour consulter tous les renseignements bibliographiques sur les Normes internationales, Spécifications techniques, Rapports techniques et autres documents de l'IEC. Disponible pour PC, Mac OS, tablettes Android et iPad.

Recherche de publications IEC - www.iec.ch/searchpub

La recherche avancée permet de trouver des publications IEC en utilisant différents critères (numéro de référence, texte, comité d'études,...). Elle donne aussi des informations sur les projets et les publications remplacées ou retirées.

IEC Just Published - webstore.iec.ch/justpublished

Restez informé sur les nouvelles publications IEC. Just Published détaille les nouvelles publications parues. Disponible en ligne et aussi une fois par mois par email.

Electropedia - www.electropedia.org

Le premier dictionnaire en ligne de termes électroniques et électriques. Il contient 20 000 termes et définitions en anglais et en français, ainsi que les termes équivalents dans 15 langues additionnelles. Egalement appelé Vocabulaire Electrotechnique International (IEV) en ligne.

Glossaire IEC - std.iec.ch/glossary

65 000 entrées terminologiques électrotechniques, en anglais et en français, extraites des articles Termes et Définitions des publications IEC parues depuis 2002. Plus certaines entrées antérieures extraites des publications des CE 37, 77, 86 et CISPR de l'IEC.

Service Clients - webstore.iec.ch/csc

Si vous désirez nous donner des commentaires sur cette publication ou si vous avez des questions contactez-nous: csc@iec.ch.



IEC 60086-3

Edition 4.0 2016-05

INTERNATIONAL STANDARD

NORME INTERNATIONALE

Primary batteries – **STANDARD PREVIEW**
Part 3: Watch batteries **(standards.iteh.ai)**

Piles électriques – **IEC 60086-3:2016**
Partie 3: Piles pour montres **(standards.iteh.ai/catalog/standards/sist/81a9957f-44d3-4efa-99ba-9a05894ad460/iec-60086-3-2016)**

INTERNATIONAL
ELECTROTECHNICAL
COMMISSION

COMMISSION
ELECTROTECHNIQUE
INTERNATIONALE

ICS 29.220.10; 39.040.10

ISBN 978-2-8322-3402-0

**Warning! Make sure that you obtained this publication from an authorized distributor.
Attention! Veuillez vous assurer que vous avez obtenu cette publication via un distributeur agréé.**

CONTENTS

FOREWORD.....	4
INTRODUCTION.....	6
1 Scope.....	7
2 Normative references.....	7
3 Terms and definitions	7
4 Physical requirements.....	8
4.1 Battery dimensions, symbols and size codes	8
4.2 Terminals.....	10
4.3 Projection of the negative terminal (h_5).....	10
4.4 Shape of negative terminal.....	10
4.5 Mechanical resistance to pressure.....	11
4.6 Deformation	11
4.7 Leakage.....	11
4.8 Marking.....	12
4.8.1 General	12
4.8.2 Disposal	12
5 Electrical requirements	12
5.1 Electrochemical system, nominal voltage, end-point voltage and open-circuit voltage.....	12
5.2 Closed circuit voltage U_{CC} (CCV), internal resistance and impedance.....	13
5.3 Capacity	13
5.4 Capacity retention.....	13
6 Sampling and quality assurance.....	13
7 Test methods.....	13
7.1 Shape and dimensions	13
7.1.1 Shape requirement.....	13
7.2 Electrical characteristics.....	14
7.2.1 Environmental conditions	14
7.2.2 Equivalent circuit – effective internal resistance – DC method.....	14
7.2.3 Equipment	15
7.2.4 Measurement of open-circuit voltage U_{OC} (OCV) and closed circuit voltage U_{CC} (CCV)	15
7.2.5 Calculation of the internal resistance R_i	16
7.2.6 Measurement of the capacity.....	16
7.2.7 Calculation of the internal resistance R_i during discharge in case of method A (optional).....	18
7.3 Test methods for determining the resistance to leakage	20
7.3.1 Preconditioning and initial visual examination	20
7.3.2 High temperature and humidity test	20
7.3.3 Test by temperature cycles	20
8 Visual examination and acceptance conditions	21
8.1 Preconditioning	21
8.2 Magnification	21
8.3 Lighting.....	21
8.4 Leakage levels and classification.....	21
8.5 Acceptance conditions.....	23

Annex A (normative) Designation	24
Bibliography	25
Figure 1 – Dimensional drawing	8
Figure 2 – Shape of negative terminal	11
Figure 3 – Shape requirement	14
Figure 4 – Schematic voltage transient	14
Figure 5 – Curve: $U = f(t)$	15
Figure 6 – Circuitry principle	16
Figure 7 – Circuitry principle for method A	17
Figure 8 – Circuitry principle for method B	18
Figure 9 – Test by temperature cycles	20
Table 1 – Dimensions and size codes	9
Table 2 – Dimensions and size codes	10
Table 3 – Minimum values of I_1	11
Table 4 – Applied force F by battery dimensions	11
Table 5 – Standardised electrochemical systems	12
Table 6 – Test method for U_{CC} (CCV) measurement	16
Table 7 – Test method A for U_{CC} (CCV) measurement	17
Table 8 – Discharge resistance (values)	19
Table 9 – Storage conditions for the recommended test	20
Table 10 – Storage conditions for optional test	20
Table 11 – Leakage levels and classification (1 of 2)	22

INTERNATIONAL ELECTROTECHNICAL COMMISSION

PRIMARY BATTERIES –**Part 3: Watch batteries**

FOREWORD

- 1) The International Electrotechnical Commission (IEC) is a worldwide organization for standardization comprising all national electrotechnical committees (IEC National Committees). The object of IEC is to promote international co-operation on all questions concerning standardization in the electrical and electronic fields. To this end and in addition to other activities, IEC publishes International Standards, Technical Specifications, Technical Reports, Publicly Available Specifications (PAS) and Guides (hereafter referred to as “IEC Publication(s)”). Their preparation is entrusted to technical committees; any IEC National Committee interested in the subject dealt with may participate in this preparatory work. International, governmental and non-governmental organizations liaising with the IEC also participate in this preparation. IEC collaborates closely with the International Organization for Standardization (ISO) in accordance with conditions determined by agreement between the two organizations.
- 2) The formal decisions or agreements of IEC on technical matters express, as nearly as possible, an international consensus of opinion on the relevant subjects since each technical committee has representation from all interested IEC National Committees.
- 3) IEC Publications have the form of recommendations for international use and are accepted by IEC National Committees in that sense. While all reasonable efforts are made to ensure that the technical content of IEC Publications is accurate, IEC cannot be held responsible for the way in which they are used or for any misinterpretation by any end user.
- 4) In order to promote international uniformity, IEC National Committees undertake to apply IEC Publications transparently to the maximum extent possible in their national and regional publications. Any divergence between any IEC Publication and the corresponding national or regional publication shall be clearly indicated in the latter.
<http://standards.iteh.ai/catalog/standards/sist/81e99575-44d2-4ef5-90b1-2e5848e30c0a/iec-60086-3-2016>
- 5) IEC itself does not provide any attestation of conformity. Independent certification bodies provide conformity assessment services and, in some areas, access to IEC marks of conformity. IEC is not responsible for any services carried out by independent certification bodies.
- 6) All users should ensure that they have the latest edition of this publication.
- 7) No liability shall attach to IEC or its directors, employees, servants or agents including individual experts and members of its technical committees and IEC National Committees for any personal injury, property damage or other damage of any nature whatsoever, whether direct or indirect, or for costs (including legal fees) and expenses arising out of the publication, use of, or reliance upon, this IEC Publication or any other IEC Publications.
- 8) Attention is drawn to the Normative references cited in this publication. Use of the referenced publications is indispensable for the correct application of this publication.
- 9) Attention is drawn to the possibility that some of the elements of this IEC Publication may be the subject of patent rights. IEC shall not be held responsible for identifying any or all such patent rights.

International Standard IEC 60086-3 has been prepared by IEC technical committee 35: Primary cells and batteries, and ISO technical committee 114: Horology.

This fourth edition cancels and replaces the third edition published in 2011. This edition constitutes a technical revision.

This edition includes the following significant technical changes with respect to the previous edition:

- a) A harmonization of the cell sizes and service output tests with IEC 60086-2;
- b) Clarifications of Clauses 6: Sampling and Quality Assurance, 7: Test methods, and 8: Visual examination and acceptance condition;
- c) Harmonization of temperature and humidity conditions with IEC 60086-1.

This publication is published as a double logo standard.

The text of this standard is based on the following documents:

FDIS	Report on voting
35/1359/FDIS	35/1362/RVD

Full information on the voting for the approval of this standard can be found in the report on voting indicated in the above table.

This publication has been drafted in accordance with the ISO/IEC Directives, Part 2.

A list of all parts in the IEC 60086 series, published under the general title *Primary batteries*, can be found on the IEC website.

The committee has decided that the contents of this publication will remain unchanged until the stability date indicated on the IEC website under "http://webstore.iec.ch" in the data related to the specific publication. At this date, the publication will be

- reconfirmed,
- withdrawn,
- replaced by a revised edition, or
- amended.

ITEH STANDARD PREVIEW
(standards.iteh.ai)

[IEC 60086-3:2016](https://standards.iteh.ai/catalog/standards/sist/81a9957f-44d3-4efa-99ba-9a05894ad460/iec-60086-3-2016)

<https://standards.iteh.ai/catalog/standards/sist/81a9957f-44d3-4efa-99ba-9a05894ad460/iec-60086-3-2016>

INTRODUCTION

This part of IEC 60086 provides specific requirements and information for primary watch batteries. This part of IEC 60086 was prepared through joint work between the IEC and ISO to benefit primary battery users, watch designers and battery manufacturers by ensuring the best compatibility between batteries and watches.

This part of IEC 60086 will remain under continual scrutiny to ensure that the publication is kept up to date with the advances in both battery and watch technologies.

NOTE Safety information is available in IEC 60086-4 and IEC 60086-5.

iTeh STANDARD PREVIEW
(standards.iteh.ai)

[IEC 60086-3:2016](#)

<https://standards.iteh.ai/catalog/standards/sist/81a9957f-44d3-4efa-99ba-9a05894ad460/iec-60086-3-2016>

PRIMARY BATTERIES –

Part 3: Watch batteries

1 Scope

This part of IEC 60086 specifies dimensions, designation, methods of tests and requirements for primary batteries for watches. In several cases, a menu of test methods is given. When presenting battery electrical characteristics and/or performance data, the manufacturer specifies which test method was used.

2 Normative references

The following documents, in whole or in part, are normatively referenced in this document and are indispensable for its application. For dated references, only the edition cited applies. For undated references, the latest edition of the referenced document (including any amendments) applies.

IEC 60086-1:2015, *Primary batteries – Part 1: General*

IEC 60086-2:2015, *Primary batteries – Part 2: Physical and electrical specifications*

IEC 60086-4:2014, *Primary batteries – Part 4: Safety of lithium batteries*

IEC 60086-5:-1, *Primary batteries – Part 5: Safety of batteries with aqueous electrolyte*

3 Terms and definitions

For the purposes of this document, the terms and definitions given in IEC 60086-1 as well as the following terms and definitions apply.

3.1

capacitive reactance

part of the internal resistance, that leads to a voltage drop during the first seconds under load

3.2

capacity

electric charge (quantity of electricity) which a cell or battery can deliver under specified discharge conditions

Note 1 to entry: The SI unit for electric charge is the coulomb (1 C = 1 As) but, in practice, capacity is usually expressed in ampere hours (Ah).

3.3

fresh battery

undischarged battery 60 days maximum after date of manufacture

¹ To be published.

3.4 ohmic drop

part of the internal resistance that leads to a voltage drop immediately after switching the load on

4 Physical requirements

4.1 Battery dimensions, symbols and size codes

Dimensions and tolerances of batteries for watches shall be in accordance with Figure 1, Table 1 and Table 2. The dimensions of the batteries shall be tested in accordance with 7.1.

The symbols used to denote the various dimensions in Figure 1 are in accordance with IEC 60086-2:2015, Clause 4.

Dimensions in millimetres

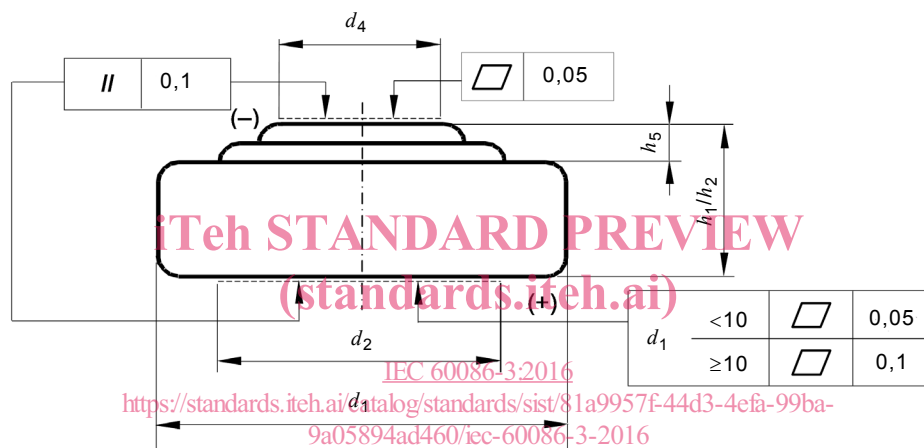

IEC

Key

- h_1 maximum overall height of the battery
- h_2 minimum distance between the flats of the positive and negative contacts
- h_5 minimum projection of the flat negative contact
- d_1 maximum and minimum diameter of the battery
- d_2 minimum diameter of the flat positive contact
- d_4 minimum diameter of the flat negative contact

NOTE This numbering follows the harmonization in the IEC 60086 series.

Figure 1 – Dimensional drawing

Table 1 – Dimensions and size codes

Dimensions in millimetres

Diameter		Height h_1/h_2																		
Code ^a	d_1	Tolerance	Code ^a																	
			10	12	14	16	18	20	21	25	26	27	30	31	32	36	42	54		
4	4,8	0 -0,15	0	0	0	0	0	0	0	0	0	0	0	0	0	0	0	0	0	
5	5,8	0 -0,15	1,05	1,25	1,45	1,65	1,65	1,65	1,65	1,65	1,65	1,65	1,65	1,65	1,65	1,65	1,65	1,65	1,65	1,65
6	6,8	0 -0,15	1,05	1,25	1,45	1,65	1,65	1,65	1,65	1,65	1,65	1,65	1,65	1,65	1,65	1,65	1,65	1,65	1,65	1,65
7	7,9	0 -0,15	1,05	1,25	1,45	1,65	1,65	1,65	1,65	1,65	1,65	1,65	1,65	1,65	1,65	1,65	1,65	1,65	1,65	1,65
9	9,5	0 -0,15	1,05	1,25	1,45	1,65	1,65	1,65	1,65	1,65	1,65	1,65	1,65	1,65	1,65	1,65	1,65	1,65	1,65	1,65
10	10,0	0 -0,30																		
11	11,6	0 -0,20	1,05	1,25	1,45	1,65	1,65	1,65	1,65	1,65	1,65	1,65	1,65	1,65	1,65	1,65	1,65	1,65	1,65	1,65
12	12,5	0 -0,25	1,20	1,20	1,20	1,60	1,60	1,60	1,60	1,60	1,60	1,60	1,60	1,60	1,60	1,60	1,60	1,60	1,60	1,60

NOTE Open boxes in the above matrix are not necessarily available for standardisation due to the concept of overlapping tolerances.

^a See Annex A.

Table 2 – Dimensions and size codes

Dimensions in millimetres

Diameter			d_4	Height h_1/h_2					
Code ^a	d_1	Tolerance		Code ^a					
				12	16	20	25	30	32
				Tolerances					
				0 -0,20	0 -0,20	0 -0,25	0 -0,30	0 -0,30	0 -0,30
16	16	0 -0,25	5,00	1,20	1,60	2,00	2,50		3,20
20	20	0 -0,25	8,00	1,20	1,60	2,00	2,50		3,20
23	23	0 -0,30	8,00	1,20	1,60	2,00	2,50	3,00	
24	24,5	0 -0,30	8,00	1,20	1,60			3,00	

NOTE Open boxes in the above matrix are not necessarily available for standardisation due to the concept of overlapping tolerances.

^a See Annex A.

4.2 Terminals

iTeh STANDARD PREVIEW

Negative contact (-): the negative contact (dimension d_4) shall be in accordance with Tables 1 and 2. This is not applied to those batteries with a two-step negative contact.

Positive contact (+): the cylindrical surface is connected to the positive terminal. Positive contact should be made to the side of the battery but may be made to the base.

4.3 Projection of the negative terminal (h_5)

The dimension h_5 shall be as follows:

$h_5 \geq 0,02$ for $h_1/h_2 \leq 1,65$

$h_5 \geq 0,06$ for $1,65 < h_1/h_2 < 2,5$

$h_5 \geq 0,08$ for $h_1/h_2 \geq 2,5$

The negative contact should be the highest point of the battery.

4.4 Shape of negative terminal

The space requirements shall be contained within an angle of 45° (see Figure 2).

The minimum values of l_1 , for different heights of h_1/h_2 , are given in Table 3.

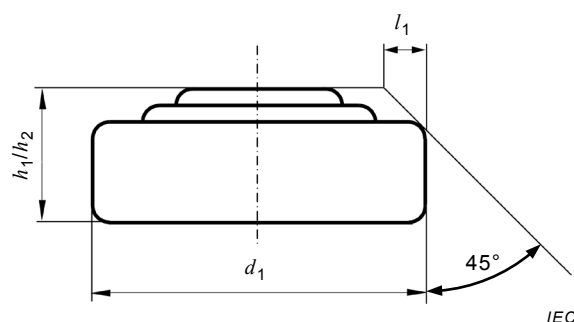

Figure 2 – Shape of negative terminal

Table 3 – Minimum values of l_1

Dimensions in millimetres

h_1/h_2	$l_1 \text{ min}$
$1 < h_1/h_2 \leq 1,90$	0,20
$1,90 < h_1/h_2 \leq 3,10$	0,35
$3,60 \leq h_1/h_2 \leq 4,20$	0,70
$5,40 \leq h_1/h_2$	0,90

4.5 Mechanical resistance to pressure

A force F (N), as specified in Table 4, applied for 10 s through a steel ball of 1 mm diameter, at the centre of each contact area, shall not cause any deformation prejudicial to the proper functioning of the battery i.e. after this test, the battery shall pass the tests specified in Clause 7.

Table 4 – Applied force F by battery dimensions

Battery dimensions		Force
d_1 mm	h_1/h_2 mm	F N
<7,9	<3,0	5
	$\geq 3,0$	10
$\geq 7,9$	<3,0	10
	$\geq 3,0$	10

4.6 Deformation

The dimensions of batteries shall conform with the relevant specified dimensions at all times including discharge to the defined end-point voltage.

NOTE 1 A battery height increase up to 0,25 mm can occur, if discharged below this voltage.

NOTE 2 A battery height decrease can occur in B and C systems as discharge continues.

4.7 Leakage

Undischarged batteries and, if required, batteries tested according to 7.2.6 shall be examined as stated in 7.3. The acceptable number of defects shall be agreed between the manufacturer and the purchaser.

4.8 Marking

4.8.1 General

The designation and the polarity shall be marked on the battery. Battery marking should not impede electrical contact. All other markings may be given on the packing instead of on the battery:

- a) designation according to normative Annex A, or common;
- b) expiration of a recommended usage period or year and month or week of manufacture;
The year and month or week of manufacture may be in code. The code is composed by the last digit of the year and by a number indicating the month. October, November and December should be represented by the letters O, Y and Z respectively.

EXAMPLE

41: January 2014;

4Y: November 2014.

- c) polarity of the positive (+) terminal;
- d) nominal voltage;
- e) name or trade mark of the supplier;
- f) cautionary advice;
- g) caution for ingestion of batteries shall be given. Refer to IEC 60086-4:2014 (7.2 a) and 9.2) and IEC 60086-5:- (7.1 l) and 9.2) for details.

NOTE Examples of the common designations can be found in Annex D of IEC 60086-2:2015.

4.8.2 Disposal

IEC 60086-3:2016

Marking of batteries with respect to the method of disposal shall be in accordance with local legal requirements.

5 Electrical requirements

5.1 Electrochemical system, nominal voltage, end-point voltage and open-circuit voltage

The requirements concerning the electrochemical system, the nominal voltage, the end-point voltage and the open-circuit voltage are given in Table 5.

Table 5 – Standardised electrochemical systems

Letter	Negative electrode	Electrolyte	Positive electrode	Nominal voltage (V_n) V	End-point voltage (EV) V	Open-circuit voltage (U_{OC} or OCV) V	
						Max.	Min.
B	Lithium (Li)	Organic electrolyte	Carbon monofluoride (CF) _x	3,0	2,0	3,70	3,00
C	Lithium (Li)	Organic electrolyte	Manganese dioxide (MnO ₂)	3,0	2,0	3,70	3,00
L	Zinc (Zn)	Alkali metal hydroxide	Manganese dioxide (MnO ₂)	1,5	1,0	1,68	1,50
S	Zinc (Zn)	Alkali metal hydroxide	Silver oxide (Ag ₂ O)	1,55	1,2	1,63	1,57

5.2 Closed circuit voltage U_{CC} (CCV), internal resistance and impedance

Closed circuit voltage and internal resistance shall be measured according to 7.2.

AC impedance should be measured with an LCR meter.

Limit values shall be agreed between the manufacturer and the purchaser.

5.3 Capacity

The capacity shall be agreed between the manufacturer and the purchaser on the basis of a continuous discharge test lasting approximately 30 days, according to 7.2.6.

5.4 Capacity retention

The capacity retention is the ratio between the capacities under the given discharge conditions measured on fresh batteries and a sample of the same lot stored during 365 days at (20 ± 2) °C and a relative humidity between 55 ± 20 %.

The ratio of capacity retention shall be agreed between the manufacturer and the purchaser. The minimum value should be at least 90 % for a period of 12 months. The capacity measurement is carried out according to 7.2.6.

For the purpose of verifying compliance with this standard, conditional acceptance may be given after completion of the initial capacity tests.

6 Sampling and quality assurance

The use of sampling plans or product quality indices should be agreed between manufacturer and purchaser.

Where no agreement is specified, refer to ISO 2859 and ISO 21747 for sampling and quality compliance assessment advice.

7 Test methods

7.1 Shape and dimensions

7.1.1 Shape requirement

The shape of the negative contact is checked preferably by optical projection or by an open gauge according to Figure 3.

The measurement method shall be agreed between the manufacturer and the purchaser.