



SLOVENSKI STANDARD

SIST ISO 6689-2:2015

01-april-2015

Nadomešča:
SIST ISO 6689:1995

Stroji za spravilo - Kombajni in funkcijski sklopi - 2. del: Ocenjevanje lastnosti in zmogljivost, definirana v slovarju

Equipment for harvesting - Combines and functional components - Part 2: Assessment of characteristics and performance defined in vocabulary

iTeh STANDARD PREVIEW
(standards.iteh.ai)

Matériel de récolte - Moissonneuses-batteuses et leurs composants fonctionnels - Partie 2: Évaluation des caractéristiques et des performances définies dans le vocabulaire

<https://standards.iteh.ai/catalog/standards/sist/07503658-bc81-4d18-b277-d2131464e4c7/sist-iso-6689-2-2015>

Ta slovenski standard je istoveten z: ISO 6689-2:1997

ICS:

65.060.50 Oprema za spravilo pridelkov Harvesting equipment

SIST ISO 6689-2:2015

en,fr

iTeh STANDARD PREVIEW
(standards.iteh.ai)

SIST ISO 6689-2:2015

<https://standards.iteh.ai/catalog/standards/sist/07503658-bc81-4d18-b277-d2131464e4c7/sist-iso-6689-2-2015>

INTERNATIONAL
STANDARD

ISO
6689-2

First edition
1997-08-01

**Equipment for harvesting — Combines and
functional components —**

Part 2:

**Assessment of characteristics and
performance defined in vocabulary**

iTeh STANDARD PREVIEW

*Matériel de récolte — Moissonneuses-batteuses et leurs composants
fonctionnels —*

*Partie 2: Évaluation des caractéristiques et des performances définies dans
le vocabulaire*

<https://standards.iteh.ai/catalog/standards/sist/07503658-bc81-4d18-b277-d2131464e4c7/sist-iso-6689-2-2015>



Reference number
ISO 6689-2:1997(E)

Foreword

ISO (the International Organization for Standardization) is a worldwide federation of national standards bodies (ISO member bodies). The work of preparing International Standards is normally carried out through ISO technical committees. Each member body interested in a subject for which a technical committee has been established has the right to be represented on that committee. International organizations, governmental and non-governmental, in liaison with ISO, also take part in the work. ISO collaborates closely with the International Electrotechnical Commission (IEC) on all matters of electrotechnical standardization.

Draft International Standards adopted by the technical committees are circulated to the member bodies for voting. Publication as an International Standard requires approval by at least 75 % of the member bodies casting a vote.

iTeh STANDARD PREVIEW

International Standard ISO 6689-2 was prepared by Technical Committee ISO/TC 23, *Tractors and machinery for agriculture and forestry*, Subcommittee SC 7, *Equipment for harvesting and conservation*.

This first edition of ISO 6689-2, together with ISO 6689-1, cancel and replace the first edition of ISO 6689:1981, of which they constitute a technical revision.

ISO 6689 consists of the following parts, under the general title *Equipment for harvesting — Combines and functional components*:

- *Part 1: Vocabulary*
- *Part 2: Assessment of characteristics and performance defined in vocabulary*

© ISO 1997

All rights reserved. Unless otherwise specified, no part of this publication may be reproduced or utilized in any form or by any means, electronic or mechanical, including photocopying and microfilm, without permission in writing from the publisher.

International Organization for Standardization
Case postale 56 • CH-1211 Genève 20 • Switzerland
Internet central@iso.ch
X.400 c=ch; a=400net; p=iso; o=isoscs; s=central

Printed in Switzerland

Equipment for harvesting — Combines and functional components —

Part 2:

Assessment of characteristics and performance defined in vocabulary

1 Scope

This part of ISO 6689 specifies the methods and requirements in assessing the dimensions and performance of a combine and its functional components as defined in ISO 6689-1. It also allows comparison of combine performance through comparative testing.

iTeh STANDARD PREVIEW

2 Normative references (standards.iteh.ai)

The following standards contain provisions which, through reference in this text, constitute provisions of this part of ISO 6689. At the time of publication, the editions indicated were valid. All standards are subject to revision, and parties to agreements based on this part of ISO 6689 are encouraged to investigate the possibility of applying the most recent editions of the standards indicated below. Members of IEC and ISO maintain registers of currently valid International Standards.

ISO 789-3:1993, *Agricultural tractors — Test procedures — Part 3: Turning and clearance diameters.*

ISO 2288:—¹), *Agricultural tractors and machines — Engine test code — Net power.*

ISO 6689-1:1997, *Equipment for harvesting — Combines and functional components — Part 1: Vocabulary.*

3 Combine assessment requirements

3.1 General

3.1.1 All dimensions and performance, defined in ISO 6689-1 from subclause 3.4 onwards and relating to combines and their functional components, shall be assessed in accordance with their definition and any requirements in this part of ISO 6689.

3.1.2 The type of crop, its general condition, the MOG:G ratio (see ISO 6689-1:1997, definition 3.1.4) and the moisture content of the grain and other materials, expressed in percentages, shall be indicated and shall meet the requirements in table 1.

1) To be published. (Revision of ISO 2288:1989)

Table 1 — Crop conditions for performance testing in specified crops

Crop	Range of MOG:G	Range of moisture content		Processing loss level %
		Grain %	MOG %	
Wheat	0,6 to 1,2	10 to 25	10 to 50	1
Barley	0,4 to 1,2	10 to 25	10 to 50	2
Rice	1 to 2,4	15 to 25	20 to 60	3
Sorghum	0,4 to 0,8	10 to 17	15 to 40	1
Maize (ear corn)	0,4 to 1	10 to 35	10 to 40	3
Oilseed rape	1 to 5	8 to 25	10 to 70	3
Soya beans	0,5 to 1,5	10 to 15	10 to 20	3

3.1.3 Moisture content of the crop, (see ISO 6689-1:1997, definition 3.1.6) shall be expressed on the wet basis. The percentage moisture of the grain shall be determined from samples taken from the grain flow into the grain tank, during the test runs. The MOG samples shall be taken from the deposited residue behind the combine, applicable to a test run just made. Both samples shall be sealed in air-tight containers.

3.1.4 Grain flow from the combine should be controlled, for each crop indicated, so as to give a processing loss level (see ISO 6689-1:1997, definition 4.2.2) during the operation specified in table 1.

In addition, in regions where difficult conditions prevail and other percentage loss levels are appropriate, the conditions shall be defined.

iTeh STANDARD PREVIEW (standards.iteh.ai)

3.2 Dimensions

Dimensions of combines shall be measured under specific conditions. The presence of equipment and additional components shall be noted.

SIST ISO 6689-2:2015

<https://standards.iteh.ai/catalog/standards/sist/07503658-bc81-4d18-0277-d2191404c739-iso-6689-2-2015>

3.2.1 Combine length (see ISO 6689-1:1997, definition 3.4.2) shall be measured, both in road travel condition and equipped for field operation.

In the field conditions, the head shall be fully raised and the reel fully forward; the longest available divider shall be fitted. If other equipment, options or attachments affect the length, such equipment shall be specified.

3.2.2 Combine height (see ISO 6689-1:1997, definition 3.4.3) shall be measured with all components in position for transport. The height with all components in position for field operation shall be specified. It shall be stated whether or not the combine is fitted with a cab.

3.2.3 Combine width (see ISO 6689-1:1997, definition 3.4.4) shall be measured both in the road travel condition and equipped for field operation. In the field condition, the head fitted shall be the same as that fitted when determining head working width and effective cutterbar width as specified in ISO 6689-1:1997, definitions 3.5.1 and 3.5.2.

3.2.4 The turning diameter (see ISO 6689-1:1997, definition 3.4.6) shall be measured in accordance with ISO 789-3, without applying the brakes.

3.2.5 The clearance diameter (see ISO 6689-1:1997, definition 3.4.7) shall be measured in accordance with ISO 789-3.

3.2.6 Where adjustable dividers are used, the minimum and maximum head working widths (see ISO 6689-1:1997, definition 3.5.1) shall be indicated.

3.2.7 Where the header width is adjustable, the minimum and maximum effective working widths of maize head cutters (see ISO 6689-1:1997, definition 3.5.3) shall be indicated, including the number of picking units.

3.2.8 The ground clearance, the maximum discharge height, the maximum clearance height, the maximum reach and the height of the cutterbar (see ISO 6689-1:1997, definitions 3.4.8, 3.4.9, 3.4.10, 3.4.11 and 3.5.6, respectively) shall be determined under the following conditions.

- Tyre and wheel or track equipment shall be stated, and tyres shall be inflated to the field operating pressures recommended by the combine manufacturer.
- The plane on which the combine is standing shall be substantially level.
- The size and type of head and reel installed at the time of measuring shall be stated.
- All optional equipment mounted on the machine shall be specified.

Furthermore, the height of the cutterbar shall be stated as the highest point and the lowest point to which the cutterbar can be raised or lowered, measured from the ground plane to the tip of the knife section.

3.2.9 Single or multiple cylinders or rotors may be disposed laterally (see figure 1) or longitudinally (see figure 2) within the combine. If multiple cylinders or rotors are used, the number shall be stated and the dimensions given as in figures 1 and 2.

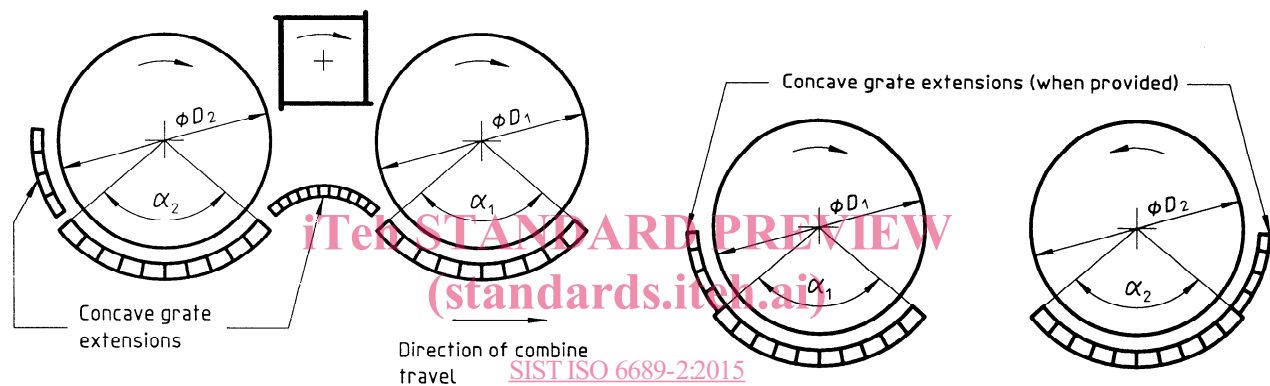

Figure 1 — Laterally disposed cylinders or rotors

Figure 2 — Longitudinally disposed cylinders or rotors (viewed from rear)

If more than one concave is used, the dimensions and surfaces of each of them shall be indicated separately.

The surfaces of rotary or axial-rotor concaves (see ISO 6689-1:1997, definition 3.2.1.4.1) shall be calculated as for other types of concave.

3.2.10 The surface of auxiliary separating devices (see ISO 6689-1:1997, definition 3.2.1.6.5) shall not be added to that of separating devices.

3.2.11 If there are adjustable sections at the rear of the straw walker, they shall be fully extended when determining the length of the walkers (see ISO 6689-1:1997, definition 3.5.22).

3.2.12 Devices that only convey material within the combine (e.g. grain pans, augers, paddles and other non-permeable conveyors) while they can contribute to good separation by stratifying the material advantageously, do no actual separation of grain from MOG, and their areas may not be classified as separating areas, or added to the other separating areas (see ISO 6689-1:1997, definitions 3.5.14, 3.5.17, 3.5.20).

3.2.13 If the machine has more than one rotor, with its related concave and separating grates, this shall be indicated with the length and the area of the separating grate (see ISO 6689-1:1997, definitions 3.5.24 and 3.5.26, respectively).

The concave grate surfaces are cumulative. This is also the case for separating grates.

3.2.14 To determine the sieve area (see ISO 6689-1:1997, definition 3.5.27) where sieve extensions are used in the standard specifications of the machine, their surfaces shall be measured by the same means and these conditions shall be stated. The component sieves and sieve extensions may be totalled and represented as total sieve area. If a grain pan extension comb (grate or fingers) is used to achieve suspension of the grain mat, its area should not be included when establishing the cleaning area.

3.2.15 Surfaces of dirt screens, recleaners, and other auxiliary cleaning devices. These areas shall be specified. Permeable surfaces and pneumatic cleaning areas shall be calculated and expressed in accordance with ISO 6689-1:1997, definitions 3.5.27 and 3.5.28, respectively.

3.2.16 For purposes of combine specification, the areas defined in ISO 6689-1:1997, definitions 3.5.9, 3.5.16, 3.5.17, 3.5.18, 3.5.23, 3.5.26 and 3.5.27 shall be listed individually and should not be used singly or in combination as a measure of machine performance or capacity.

3.3 Other characteristics

3.3.1 The engine net power (see ISO 6689-1:1997, definition 3.4.5) shall be determined in accordance with ISO 2288.

3.3.2 The throughputs defined in ISO 6689-1:1997, subclause 4.1 shall be indicated with the corresponding MOG:G ratio value (see 3.1.2).

3.3.3 When indicating the combine mass equipped for operation in the field (see ISO 6689-1:1997, definition 3.4.1.2), the accessories fitted to the machine shall be listed and their mass indicated.

ITEH STANDARD PREVIEW
(standards.iteh.ai)

SIST ISO 6689-2:2015

<https://standards.iteh.ai/catalog/standards/sist/07503658-bc81-4d18-b277-d2131464e4c7/sist-iso-6689-2-2015>