



SLOVENSKI STANDARD
SIST EN 168:2002

01-junij-2002

BUXca Yý U
SIST EN 168:1996

CgYVbc`j Ufcj Ub^c]!`AYrcXY`bYcdh] b]`dfYg_i gcj

Personal eye-protection - Non-optical test methods

Persönlicher Augenschutz - Nichtoptische Prüfverfahren

iTeh STANDARD PREVIEW
Protection individuelle de l'oeil - Méthodes d'essais autres qu'optiques
(standards.iteh.ai)

Ta slovenski standard je istoveten z: ~~SIST EN 168:2001~~ EN 168:2001

<https://standards.iteh.ai/catalog/standards/sist/001ad1c9-bca1-4558-bc72-f722131f776e/sist-en-168-2002>

ICS:

13.340.20 Varovalna oprema za glavo Head protective equipment

SIST EN 168:2002

en

iTeh STANDARD PREVIEW
(standards.iteh.ai)

SIST EN 168:2002

<https://standards.iteh.ai/catalog/standards/sist/001ad1c9-bca1-4558-bc72-f722131f776e/sist-en-168-2002>

English version

Personal eye-protection - Non-optical test methods

Protection individuelle de l'oeil - Méthodes d'essais autres
qu'optiques

Persönlicher Augenschutz - Nichtoptische Prüfverfahren

This European Standard was approved by CEN on 2 September 2001.

CEN members are bound to comply with the CEN/CENELEC Internal Regulations which stipulate the conditions for giving this European Standard the status of a national standard without any alteration. Up-to-date lists and bibliographical references concerning such national standards may be obtained on application to the Management Centre or to any CEN member.

This European Standard exists in three official versions (English, French, German). A version in any other language made by translation under the responsibility of a CEN member into its own language and notified to the Management Centre has the same status as the official versions.

CEN members are the national standards bodies of Austria, Belgium, Czech Republic, Denmark, Finland, France, Germany, Greece, Iceland, Ireland, Italy, Luxembourg, Netherlands, Norway, Portugal, Spain, Sweden, Switzerland and United Kingdom.

ITIH STANDARD PREVIEW
(standards.iteh.ai)

SIST EN 168:2002

<https://standards.iteh.ai/catalog/standards/sist/001ad1c9-bca1-4558-bc72-f722131f776e/sist-en-168-2002>



EUROPEAN COMMITTEE FOR STANDARDIZATION
COMITÉ EUROPÉEN DE NORMALISATION
EUROPÄISCHES KOMITEE FÜR NORMUNG

Management Centre: rue de Stassart, 36 B-1050 Brussels

Contents

	page
Foreword.....	4
1 Scope	5
2 Normative references	5
3 Test for increased robustness.....	5
3.1 Unmounted oculars	5
3.1.1 Apparatus	5
3.1.2 Procedure	6
3.2 Complete eye-protectors and frames	6
3.2.1 Apparatus	6
3.2.2 Procedure	7
3.2.3 Points of impact	7
4 Test for minimum robustness of oculars with filtering effect and cover plates	8
4.1 Apparatus	8
4.1.1 Loading device.....	8
4.1.2 Specimen support.....	8
4.2 Procedure	8
5 Test for stability at elevated temperature.....	9
5.1 Apparatus	9
5.2 Procedure	9
6 Test for resistance to ultraviolet radiation	10
6.1 Apparatus	10
6.2 Procedure	10
7 Test for resistance to ignition.....	10
7.1 Apparatus	10
7.2 Procedure	10
8 Test for resistance to corrosion.....	10
9 Test for resistance to high-speed particles and resistance to high speed particles at extremes of temperature	11
9.1 Apparatus	11
9.1.1 Head-form	11
9.1.2 Propulsion equipment	11
9.2 Procedure	11
9.2.1 Resistance to high speed particles.....	11
9.2.2 Resistance to high speed particles at extremes of temperature	12
10 Test for protection against molten metals	12
10.1 Test for non-adherence of molten metals	12
10.1.1 Principle.....	12
10.1.2 Apparatus	12
10.1.3 Procedure	13
10.2 Test for area of coverage of face shields	14
10.2.1 Principle.....	14
10.2.2 Apparatus	14
10.2.3 Procedure	14
10.2.4 Evaluation.....	14
11 Test for resistance to penetration by hot solids.....	15
11.1 Apparatus	15
11.2 Procedure	16
12 Test for protection against droplets and liquid splashes.....	16
12.1 Test for protection against droplets (for goggle type eye-protectors).....	16
12.1.1 Apparatus	16

12.1.2	Procedure	16
12.1.3	Evaluation	17
12.2	Test for protection against liquid splashes (for face-shields)	17
13	Test for protection against large dust particles	17
13.1	Apparatus	17
13.2	Procedure	18
13.3	Evaluation	18
14	Test for protection against gases and fine dust particles	19
14.1	Apparatus	19
14.2	Procedure	20
14.3	Evaluation	20
15	Test for resistance to surface damage by fine particles	20
15.1	Apparatus	20
15.1.1	Falling sand apparatus	20
15.1.2	Sand	20
15.1.3	Measuring apparatus	20
15.1.4	Reference samples	20
15.2	Samples	20
15.3	Procedure	21
15.4	Evaluation	21
16	Test for resistance to fogging of oculars	23
16.1	Apparatus	23
16.2	Samples	24
16.3	Procedure and evaluation	24
17	Head-form	25
18	Assessment of Field of Vision	28
19	Assessment of lateral protection	29
19.1	Apparatus	29
19.2	Procedure	29
19.3	Evaluation	29
Annex A	(informative) Uncertainty of measurement and results interpretation	30
A.1	Test report and uncertainty of measurement	30
Annex ZA	(informative) Clauses of this European Standard addressing essential requirements or other provisions of EU Directives	32

iTech STANDARD PREVIEW

(standards.iteh.ai)

SIST EN 168:2002

<https://standards.iteh.ai/catalog/standards/sist/001ad1c9-bca1-4558-bc72-5509f01e-4e01>

SIST EN 168:2002

Foreword

This European Standard has been prepared by Technical Committee CEN /TC 85, "Eye-protective equipment", the secretariat of which is held by AFNOR.

This European Standard shall be given the status of a national standard, either by publication of an identical text or by endorsement, at the latest by May 2002, and conflicting national standards shall be withdrawn at the latest by May 2002.

This document replaces EN 168:1995.

This European Standard has been prepared under a mandate given to CEN by the European Commission and the European Free Trade Association, and supports essential requirements of EU Directive(s).

For relationship with EU Directive(s), see informative annex ZA, which is an integral part of this standard.

The annexes A and ZA are informative.

According to the CEN/CENELEC Internal Regulations, the national standards organizations of the following countries are bound to implement this European Standard: Austria, Belgium, Czech Republic, Denmark, Finland, France, Germany, Greece, Iceland, Ireland, Italy, Luxembourg, Netherlands, Norway, Portugal, Spain, Sweden, Switzerland and the United Kingdom.

iTeh STANDARD PREVIEW
(standards.iteh.ai)

SIST EN 168:2002

<https://standards.iteh.ai/catalog/standards/sist/001ad1c9-bca1-4558-bc72-f722131f776e/sist-en-168-2002>

1 Scope

This European Standard specifies non-optical test methods for eye-protectors, the requirements for which are contained in other European Standards.

Alternative test methods may be used if shown to be equivalent.

The optical test methods are given in EN 167.

A definition of terms is given in EN 165.

2 Normative references

This European Standard incorporates by dated or undated reference, provisions from other publications. These normative references are cited at the appropriate places in the text, and the publications are listed hereafter. For dated references, subsequent amendments to or revisions of any of these publications apply to this European Standard only when incorporated in it by amendment or revision. For undated references the latest edition of the publication referred to applies (including amendments).

EN 165, *Personal eye-protection — Vocabulary.*

EN 166, *Personal eye-protection — Specifications.*

EN 167, *Personal eye-protection — Optical test methods.*

ISO 565, *Test sieves — Metal wire cloth, perforated metal plate and electroformed sheet — Nominal sizes of openings.*

iTech STANDARD PREVIEW
(standards.itech.ai)

3 Test for increased robustness

[SIST EN 168:2002](#)

[https://standards.itech.ai/catalog/standards/sist/001ad1c9-bca1-4558-bc72-](https://standards.itech.ai/catalog/standards/sist/001ad1c9-bca1-4558-bc72-f722131f776e/sist-en-168-2002)

[f722131f776e/sist-en-168-2002](https://standards.itech.ai/catalog/standards/sist/001ad1c9-bca1-4558-bc72-f722131f776e/sist-en-168-2002)

New specimens shall be used for this test.

3.1 Unmounted oculars

3.1.1 Apparatus

The support for the ocular (see Figure 1) shall be a steel or rigid plastic cylinder with an internal diameter of $(35,0 \pm 0,1)$ mm and an outside diameter of $(41,0 \pm 0,1)$ mm. The cylinder shall be inserted into, or be an integral part of a steel base. The ocular shall be cushioned by a silicone seating ring firmly attached to the top of the tube.

This seating ring shall be made of silicone rubber of (40 ± 5) I.R.H.D and shall have an inside diameter of $(35,0 \pm 0,4)$ mm and cross sections of 3 mm x 3 mm nominal dimensions.

The combined mass of the support shall be at least 12 kg.

A load ring of mass (250 ± 5) g is placed on the ocular. The ring has an inside diameter the same as that of the support tube, and any convenient outside diameter. A silicone seating ring having the same dimensions and hardness as the one attached to the top of the support tube is placed between the load ring and the ocular. A piece of carbon paper on a piece of white paper is placed at the base of the 1,5 mm deep cavity in the ocular support (see Figure 1).

For curved oculars with a cylindrical component, the test support tube and load ring shall be curved to conform to the concave and convex surfaces of the ocular respectively, and the dimensions of 3 mm and 4,5 mm shall apply to the deepest point of the circular support. (See Figure 1).

If the ocular is of insufficient dimensions to enable its entire periphery to be adequately supported, suitable adaptor sleeves shall be used.

EN 168:2001 (E)

3.1.2 Procedure

Centre the intended points of impact of the ocular on the support tube. Adjust the apparatus so that a 22 mm nominal diameter steel ball of 43 g minimum mass falling from $(1,3^{+0}_{-0,03})$ m strikes the ocular within a 5 mm radius from the centre of the support tube. This height will provide an impact speed of approximately 5,1 m/s.

Impacts shall be directed at the visual centre(s) of the oculars. For unmounted oculars covering one eye and for which the visual centre cannot be established, then the geometric centre shall be used.

NOTE Visual centre is as defined in EN 166.

The impacts are carried out in the following conditions:

- a) with the ocular heated to (55 ± 2) °C and maintained at this temperature for at least 1 h;
- b) with the ocular cooled to a temperature of (-5 ± 2) °C and maintained at this temperature for at least 1 h.

New oculars shall be used for each individual impact and for each temperature condition. The impact shall be applied within 30 s of temperature conditioning.

The test shall be carried out at (23 ± 5) °C.

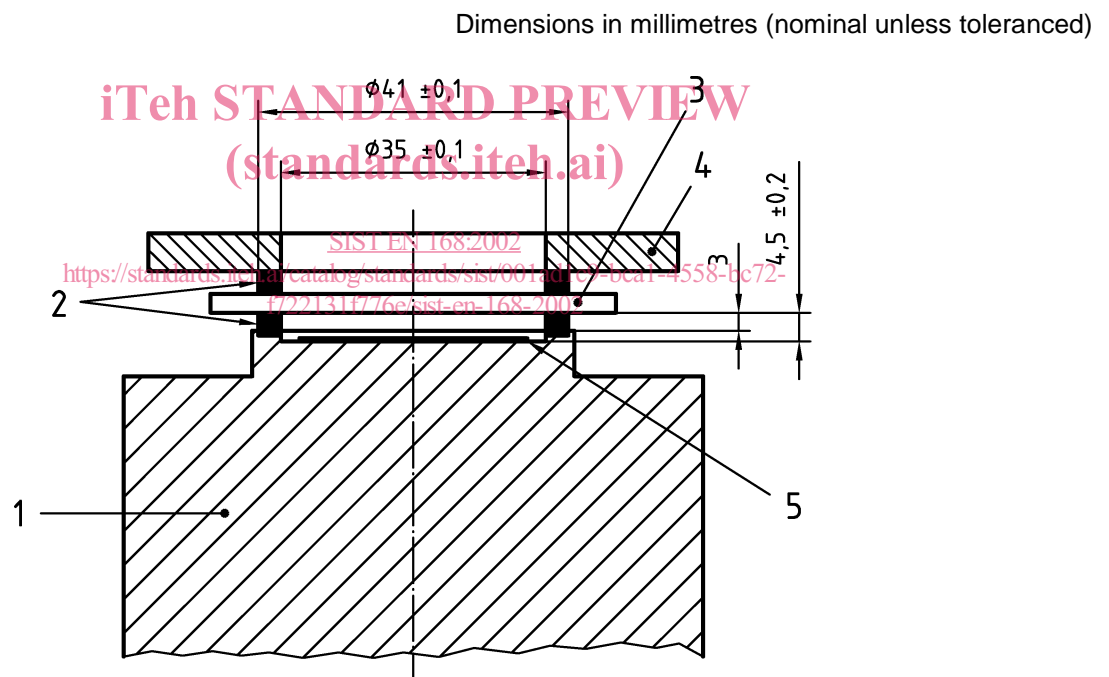

Key

- 1 Supporting plate (12 kg minimum)
- 2 Silicone seating rings
- 3 Ocular
- 4 Load ring (250 ± 5) g
- 5 Carbon paper on white paper

Figure 1 — Holding device for oculars for the increased robustness test

3.2 Complete eye-protectors and frames

3.2.1 Apparatus

- 3.2.1.1 Appropriate head-form, as defined in clause 17.

3.2.1.2 A device enabling a 22 mm nominal diameter steel ball of 43 g minimum mass to be projected at a specified point on the eye-protector at a speed of approximately 5,1 m/s.

3.2.2 Procedure

The eye-protector to be tested shall be placed on the appropriate head-form in the position corresponding to normal use.

If the frame only is to be assessed then oculars meeting the requirements of 3.1 (increased robustness) shall be fitted to the frame.

A sheet of carbon paper on top of a sheet of white paper is attached to the head-form behind the eye-protector. The head-form and eye-protector assembly is positioned in the test apparatus.

The ball is projected at the points of impact defined in 3.2.3.

For spectacles with no lateral protection the ball shall strike the sidearm within the prescribed lateral protection area on a vertical plane through the impact centre. (See 3.2.3).

The impacts are carried out in the following conditions:

- a) with the eye-protector heated to (55 ± 2) °C and maintained at this temperature for at least 1 h;
- b) with the eye-protector cooled to a temperature of (-5 ± 2) °C and maintained at this temperature for at least 1 h.

New eye-protectors shall be used for each individual point of impact and for each temperature condition. The impact shall be applied within 30 s of temperature conditioning.

The tests shall be conducted at an ambient temperature of (23 ± 5) °C.

3.2.3 Points of impact

There are four impact points, and these are defined with respect to the head-form rather than the eye-protector. The ball is aimed at these impact points with the eye-protector mounted in the normal use position.

The impact points shall be considered as any single point within a 10 mm radius of one of four impact centres. These impact centres are denoted by an asterisk (*) in Figure 11.

With respect to the test schedule contained in EN 166, the four impact points are defined as follows:

1. the left eye frontal;
2. the right eye frontal;
3. the left eye side;
4. the right eye side.

For frontal impacts at the two eye centres the ball is projected normal to the vertical axis of the head-form and parallel to its optical axis along each line of sight.

For lateral impacts the head-form is rotated about its vertical axis by 90° (left and right) from the frontal impact position.

The head-form may be moved horizontally and vertically to select any single impact point lying within 10 mm of the specified impact centres.

As stated in 3.2.2, new eye-protectors shall be used for each individual impact.

4 Test for minimum robustness of oculars with filtering effect and cover plates

New specimens are used for this test.

4.1 Apparatus

See Figure 2.

4.1.1 Loading device

A steel ball of 22 mm nominal diameter is fastened to the lower end of a tube, whose length is 70 mm nominal.

The total loading mass is such that the force acting on the ocular is (100 ± 2) N.

4.1.2 Specimen support

The support for the ocular (see Figure 2) shall be a steel cylinder with an internal diameter of $(35,0 \pm 0,1)$ mm and an outside diameter of $(41,0 \pm 0,1)$ mm. The cylinder shall be inserted into, or be part of, a steel base.

The specimen is placed between two seating rings made of silicone rubber of (40 ± 5) I.R.H.D. having an inside diameter of $(35,0 \pm 0,4)$ mm and cross sections of 3 mm x 3 mm nominal dimensions. The silicone seating rings are fixed to the steel supporting plate and the load ring respectively.

If the specimen ocular is of insufficient dimensions to enable its entire periphery to be adequately supported, suitable adaptor sleeves shall be used.

The load ring shall have a mass of (250 ± 5) g. By its weight, it presses the upper silicone seating ring against the upper surface of the specimen.

A sheet of carbon paper on top of a sheet of white paper is placed on the supporting steel plate at the base of the 1,5 mm deep cavity.

[SIST EN 168:2002](https://standards.iteh.ai/catalog/standards/sist/001ad1c9-bca1-4558-bc72-f722131f776e/sist-en-168-2002)

<https://standards.iteh.ai/catalog/standards/sist/001ad1c9-bca1-4558-bc72-f722131f776e/sist-en-168-2002>

4.2 Procedure

4.2.1 The test is carried out at (23 ± 5) °C.

4.2.2 Align the central vertical axis of the loading tube with that of the specimen support.

4.2.3 Position the specimen on the support with the "eye side" downwards and place the load ring on the specimen. For curved oculars with a cylindrical component the supporting plate and the load ring are curved to conform to the surface of the ocular, and the dimensions of 3 mm and 4,5 mm shall apply to the deepest point of the circular support.

4.2.4 Adjust the position of the specimen such that the load ring axis (4.2.2) passes through the visual centre of the specimen. If the visual centre cannot be established the geometric centre shall be used.

NOTE Visual centre is as defined in EN 166.

4.2.5 The loading mass is lowered on to the ocular at a speed not exceeding 400 mm/min. The force of (100 ± 2) N is maintained for (10 ± 2) s. The loading mass is then removed.

Dimensions in millimetres (nominal unless toleranced)

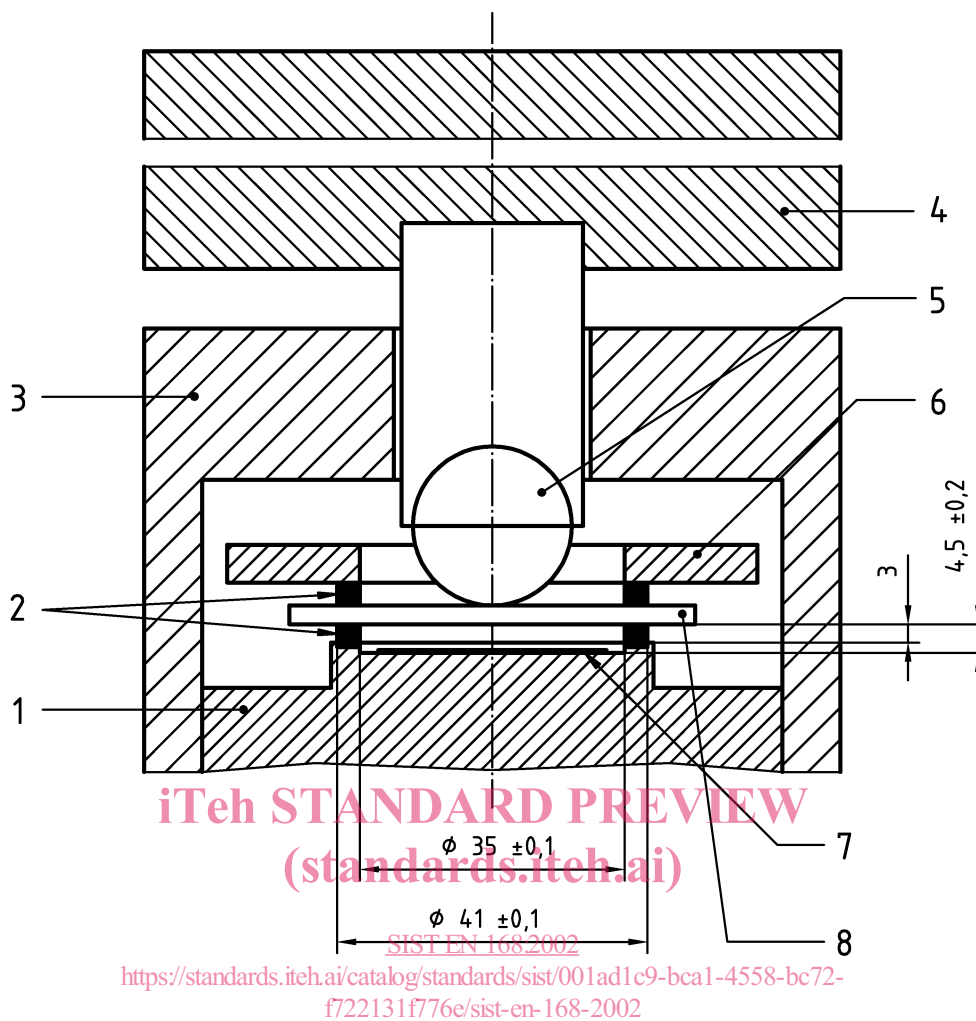
**Key**

- 1 Supporting plate
- 2 Silicone seating rings
- 3 Guiding block
- 4 Loading mass (100 ± 2) N
- 5 Steel ball
- 6 Load ring (250 ± 5) g
- 7 Carbon paper on white paper
- 8 Ocular

Figure 2 — Apparatus for minimum robustness (static deformation) test

5 Test for stability at elevated temperature

New specimens are used for this test.

5.1 Apparatus

Oven, capable of maintaining a temperature of (55 ± 2) °C.

5.2 Procedure

Place the specimen in a position corresponding to normal use, in the oven for (60 ± 5) min at a temperature of (55 ± 5) °C. Then remove it and allow to stabilise at (23 ± 5) °C for a minimum of 60 min prior to visual examination.

6 Test for resistance to ultraviolet radiation

6.1 Apparatus

Fused-silica envelope high-pressure xenon lamp. The power of the lamp shall be between 400 W and 500 W, with a preferred value of 450 W. The spectral transmittance of the lamp envelope shall be at least 30 % at 200 nm.

NOTE Suitable lamp references are XBO-450 W/4 and CSX-450 W/4. These lamps produce UV radiation with an appreciable amount of UVC radiation. This is appropriate, since industrial processes (for example, welding) produce appreciable amounts of UVC radiation.

WARNING Precautions should be taken against potential generation and build up of ozone.

6.2 Procedure

New specimens are used for this test. The test equipment is operated within an environment of temperature (23 ± 5) °C.

Expose the external face of the ocular to radiation from a fused silica envelope high-pressure xenon lamp (see 6.1).

The angle of incidence of the radiation on the specimen surface shall be essentially perpendicular. The distance from the axis of the lamp to the nearest point on the sample shall be (300 ± 10) mm. The exposure time shall be $(50 \pm 0,2)$ h at a lamp power of 450 W.

New lamps shall be burned in for $(50 \pm 0,2)$ h.

7 Test for resistance to ignition

iTeh STANDARD PREVIEW
(standards.iteh.ai)

7.1 Apparatus

7.1.1 Steel rod, (300 ± 3) mm long and 6 mm nominal diameter with end faces which are flat and perpendicular to its longitudinal axis.

7.1.2 Heat source.

7.1.3 Thermocouple and temperature indicating device.

7.1.4 Timer, capable of measuring an elapsed time of 10 s with an uncertainty of $\pm 0,1$ s.

7.2 Procedure

Heat one end of the steel rod over a length of at least 50 mm to a temperature of (650 ± 20) °C. Measure the temperature of the rod by means of the thermocouple attached at a distance of (20 ± 1) mm from the heated end of the rod. Press the heated face of the rod (long axis vertically) against the surface of the test sample (the contact force being equal to the weight of the rod) for a period of $(5,0 \pm 0,5)$ s, and then remove it.

Carry out the test on all externally exposed parts of the eye-protector, except elastic headbands and textile edging.

Carry out a visual inspection during the test in order to establish whether the test samples ignite or continue to glow.

The tests are performed in an environment of temperature (23 ± 5) °C.

8 Test for resistance to corrosion

Remove all contamination, particularly oil and grease from the metal parts of the specimen.

Immerse the specimen for (15 ± 1) min in a boiling, aqueous, $(10,0 \pm 0,5)$ % by mass solution of sodium chloride.