



Designation: F 2020 – 02a

Standard Practice for Design, Construction, and Procurement of Emergency Medical Services Systems (EMSS) Ambulances¹

This standard is issued under the fixed designation F 2020; the number immediately following the designation indicates the year of original adoption or, in the case of revision, the year of last revision. A number in parentheses indicates the year of last reapproval. A superscript epsilon (ϵ) indicates an editorial change since the last revision or reapproval.

1. Scope

1.1 This practice covers certified, tested, commercial type, EMSS ambulances built on chassis that are suitable for the intended application and meet the requirements herein. The ambulances are front or rear wheel driven (4x2) or four wheel driven (4x4) and warranted as specified in Section 9.

1.1.1 *Definition of Ambulance*—An ambulance is a vehicle for emergency medical care which provides: a driver's compartment; a patient compartment to accommodate an emergency medical technician (EMT)/paramedic and two litter patients (one patient located on the primary cot and a secondary patient on a folding litter located on the squad bench) so positioned that the primary patient can be given intensive life-support during transit; equipment and supplies for emergency care at the scene as well as during transport; two-way radio communication; and, when necessary, equipment for light rescue/extrication procedures. The ambulance shall be designed and constructed to afford safety, comfort, and avoid aggravation of the patient's injury or illness.

1.1.2 This practice may be used to procure an ambulance and the applicable additional systems and equipment.

1.1.3 Purchasers should follow the ordering data in 9.2 to aid them with the preparation of their procurement specification, requisition, and contract. The purpose of this practice is to describe minimum requirements for design, construction, performance, equipment, testing, and appearance of EMSS ambulances that are authorized to display the "Star of Life" symbol so as to provide a practical degree of standardization. The reasons for such standardization are to provide ambulances that are easily detected, nationally recognizable, properly constructed, easily maintained, and, when appropriately equipped, will enable Emergency Medical Technicians (EMTs) to safely and reliably perform their functions as basic and advanced prehospital life support providers as set forth in national EMSS standard training guidelines. These functions include:

1.1.3.1 Responding to, providing appropriate basic or advanced life support, on-site, to persons reported experiencing acute injury or illness in a pre-hospital setting, and transporting them, while continuing such life support care, to an appropriate medical facility for definitive care.

1.1.3.2 Providing interhospital critical transport care.

1.1.3.3 Transporting essential personnel and equipment to and from the site of a multiple medical emergency or a triage site and transporting appropriately triaged patients to designated medical facilities.

1.1.3.4 Other functions deemed appropriate by EMSS ambulance service managers and approved by designated EMSS medical directors.

1.2 *"Star of Life" Certification*—Ambulance manufacturer/contractor shall furnish the purchaser(s) citing this practice an authenticated certification and label (see 6.19) that certifies a "Star of Life" ambulance and equipment complying with this practice and applicable amendments (if any) in effect on the date of manufacture (see 7.3). Ambulance vehicles so certified may display the registered "Star of Life" symbol, as defined by the U.S. Department of Transportation (DOT) and the National Highway Traffic Safety Administration (NHTSA), see Fig. 1.

1.3 *Classification*—"Star of Life" ambulance designs included in this practice may be described in terms of their body type (I, II, or III), class of drive ("1" for two rear wheel drive or "2" for four wheel drive), and floor configuration (A for Advanced Life Support or B for Basic Life Support). Such descriptions may be used to define a variety of ambulance designs which are eligible for certification as "Star of Life" ambulances. (To specify, see 9.2.2 and 9.2.3).

NOTE 1—For optional advanced life support (ALS) applications, users should consider specifying a modular (Type I or III) ambulance. Modular ambulances provide additional space and compartmentation for cardiac monitors, drug cases, and so forth. The basic life support (BLS) configuration is standard on all types.

1.3.1 *Type I*—Conventional truck, cab-chassis with modular ambulance body (see Fig. 2).

| Class | Configuration |
|-----------------------------|---------------|
| Two rear wheel driven (4x2) | A or B |
| Four wheel driven (4x4) | A or B |

¹ This practice is under the jurisdiction of ASTM Committee F30 on Emergency Medical Services and is the direct responsibility of Subcommittee F30.01 on EMS Equipment.

Current edition approved Oct. 10, 2002. Published January 2003. Originally published as F 2020 – 00. Last previous edition F 2020 – 02.

"Star of Life Symbol"

The "Star of Life" is a six-barred cross upon which is superimposed the Staff of Aesculapius (es"cu-la'pi-us) who, in both Greek and Roman Mythology, was the god of medicine and healing.

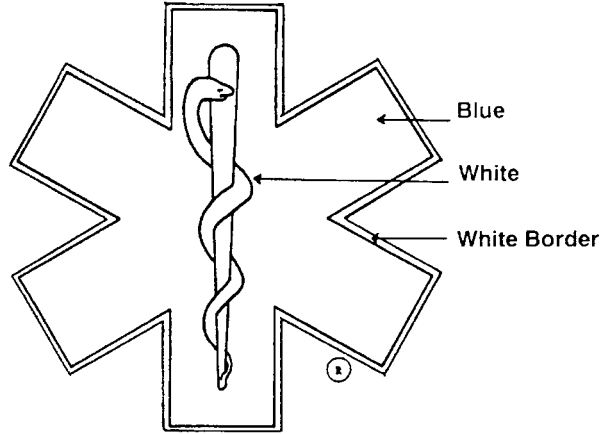

DIMENSIONS

| Dimensions (min.): | Size A | Size B | Size C | Size D |
|--------------------|--------------|----------------|-----------------|---------------|
| Length of bar | 76 mm (3") | 30.5 cm (12") | 40.6 cm (16") | 81.3 cm (32") |
| Width of bar | 25 mm (.75") | 76 mm (3") | 10.2 cm (4") | 20.3 cm (8") |
| Length of staff | 63 mm (2.5") | 24.1 cm (9.5") | 31.7 cm (12.5") | 63.5 cm (25") |
| White border | (.25') | (.375') | (.5') | - |

All angles 60°

Deviations must be proportionate.

FIG. 1 "Star of Life Symbol"

Configuration A: Elevating cot and squad bench for ALS (see 6.1.5.1 and 6.11.4).

Configuration B: Elevating cot and squad bench for BLS (see 6.1.5.2).

1.3.1.1 *Type I—AD (Additional Duty—with increased GVWR, storage, and payload capacity)*—A or B or Neonatal, Critical Patient Transport, or A or B with Rescue and Fire Suppression Package (see 6.1.2.1).

| Class | Configuration |
|-----------------------------|---------------|
| Two rear wheel driven (4x2) | A or B* |
| Four wheel driven (4x4) | A or B* |

*As specified by purchaser. The configuration shall provide for a neonatal, critical patient transport, configuration A or B with fire suppression package and rescue capability when specified.

1.3.2 *Type II*—Standard van, integral cab-body ambulance (see 6.1.3 and Fig. 3).

| Class | Configuration |
|-----------------------------|---------------|
| Two rear wheel driven (4x2) | A** or B |
| Four wheel driven (4x4)* | A** or B |

*Requires conversion of chassis to four wheel drive (4x4), (see 6.1.6).

**On a Type II, ALS features are limited, (see 9.2.3).

1.3.3 *Type III*—Cutaway van, cab-chassis with integral or containerized modular body ambulance (see 6.1.4 and Fig. 4).

| Class | Configuration |
|-----------------------------|---------------|
| Two rear wheel driven (4x2) | A or B |
| Four wheel driven (4x4)* | A or B |

Type I Ambulance
Conventional Cab-Chassis with Modular Body

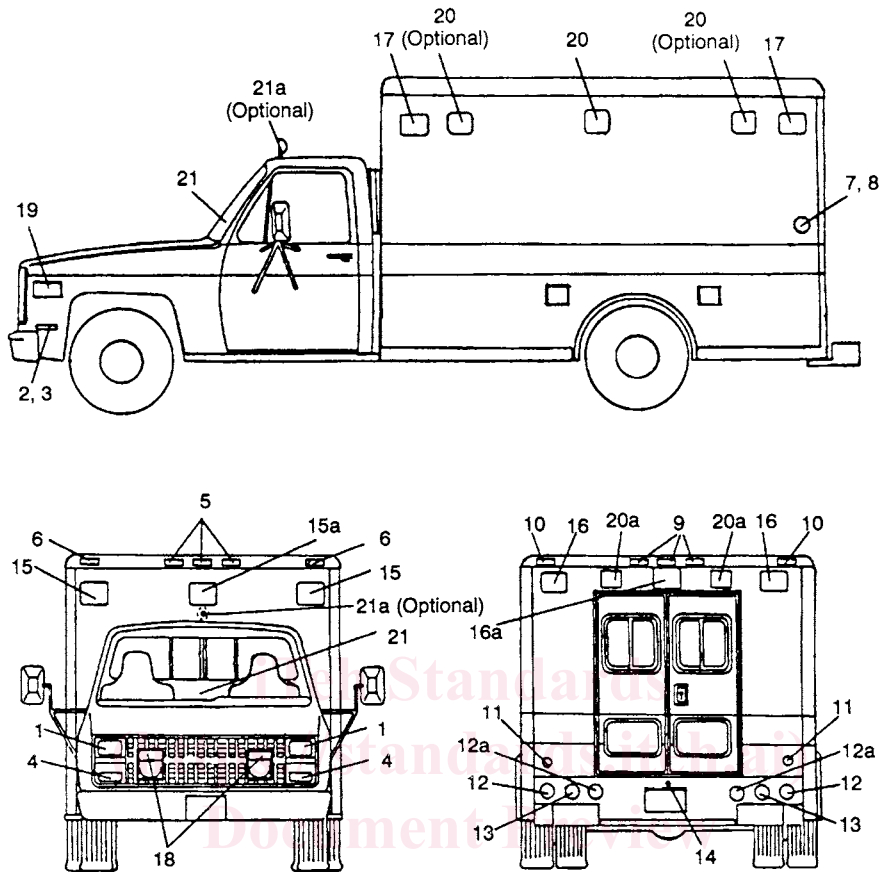

ASTM F2020-02a

- | | |
|---|--|
| 1. Headlamp, (2) white [(4) white optional] | 13. Rear backup lamp, (1) white |
| 2. Front side marker lamp, (2) amber | 14. Rear license plate lamp, (1) white |
| 3. Front side reflector, (2) amber | 15. Front warning light, (2) red |
| 4. Front turn signal, (2) amber, (includes vehicular hazard warning signal flasher) | 15a. Front warning light, (1) white |
| 5. Front identification lamps, (3) amber | 16. Rear warning light, (2) red |
| 6. Front clearance lamp, (2) amber | 16a. Rear warning light, (1) amber |
| 7. Rear side marker lamp, (2) red | 17. Side warning light, (2) red per side |
| 8. Rear side reflector, (2) red | 18. Grille light, (2) red |
| 9. Rear identification lamps, (3) red | 19. Intersection lights, (1) red per side |
| 10. Rear clearance lamp, (2) red | 20. Side floodlight, (2) white |
| 11. Rear reflector, (2) red | 20a. Rear floodlight, (1) white |
| 12. Rear, stop, tail, lamp, (2) red | 21. Spotlight, (white) hand held |
| 12a. Rear turn signal, (2) amber. Includes vehicular hazard warning signal flasher. (optional location) | 21a. Spotlight, (white), (optional location) |

Lamps and reflectors may be mounted at other practicable locations provided locations and visibility requirements of Federal Motor Vehicle Safety Standard No. 108 are met. The warning lights shown are for the standard warning light systems. The number of devices and their locations may be different in alternative warning light systems

FIG. 2 Type I Ambulance

Type II Ambulance
Standard Van, Forward Control, Integral Cab-Body Ambulance

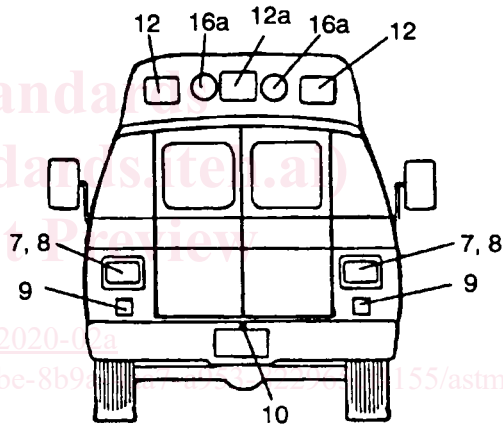
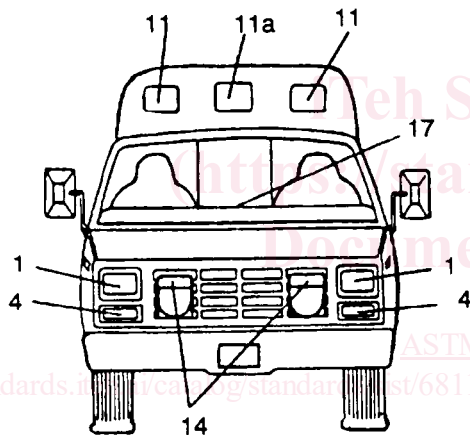
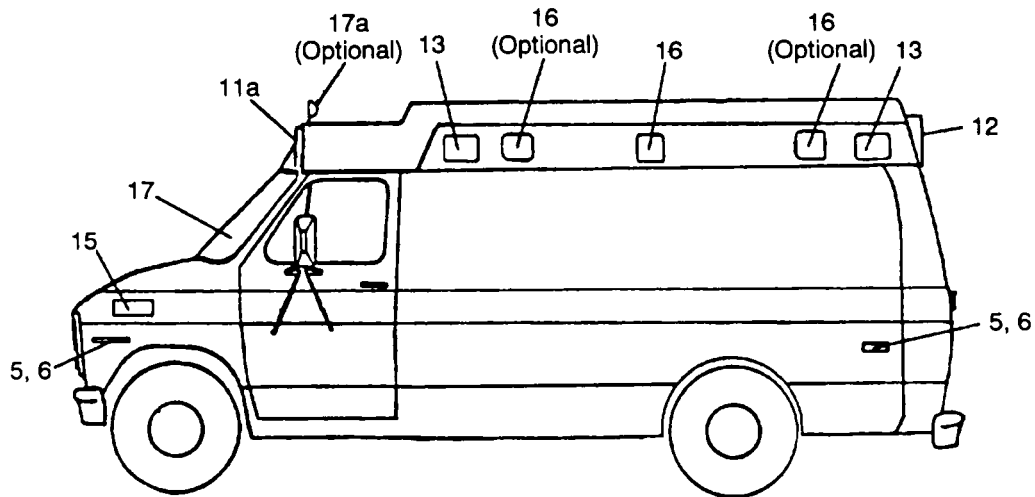

- | | |
|--|--|
| <ol style="list-style-type: none"> 1. Headlamp, (2) white (4 white optional) *2. Front side marker lamp, (2) amber 3. Front side reflector, (2) amber 4. Front turn signal, (2) amber (Includes vehicular hazard warning signal flasher) 5. Rear side marker lamp, (2) red 6. Rear side reflector, (2) red 7. Rear reflector, (2) red 8. Rear stop, tail & turn signal lamp, (2) red, (turn signal section may be amber, Includes vehicular hazard warning signal flasher) 9. Rear backup lamp, (1) white 10. Rear license plate lamp, (1) white | <ol style="list-style-type: none"> 11. Front warning light, (2) red 11a. Front warning light, (1) white 12. Rear warning light, (2) red 12a. Rear warning light, (1) amber 13. Side warning light, (2) red per side 14. Grille light, (2) red 15. Intersection lights, (1) red per side 16. Side floodlight, (2) white 16a. Rear floodlight, (1) 17. Spotlight, hand held, white 17a. Spotlight (white, optional location) <p>*Flashes with front/rear turn signal & vehicular hazard warning signal flasher.</p> |
|--|--|

Lamps and reflectors may be mounted in other practicable locations provided location and visibility requirements of Federal Motor Vehicle Safety Standard No. 108 are met. The warning lights shown are for the standard warning light systems. The number of devices and their locations may be different in alternative warning light systems.

FIG. 3 Type II Ambulance

TYPE III AMBULANCE

Specialty Van, Forward Control and Control Integral Cab-Body
or Containerized Modular Ambulance

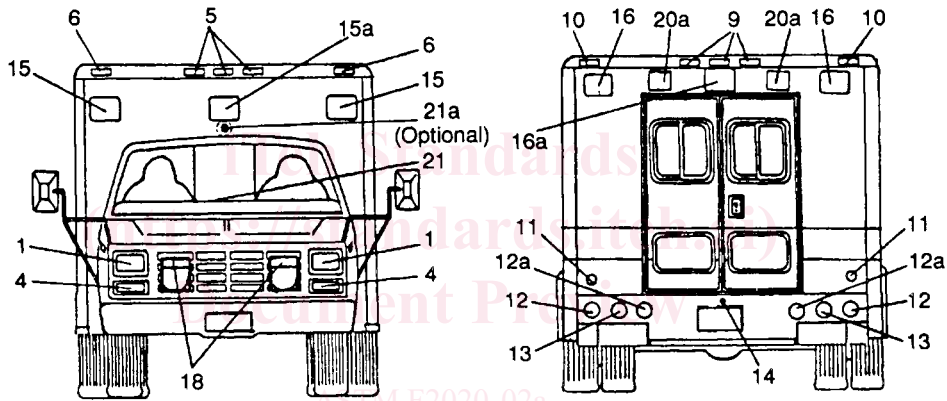
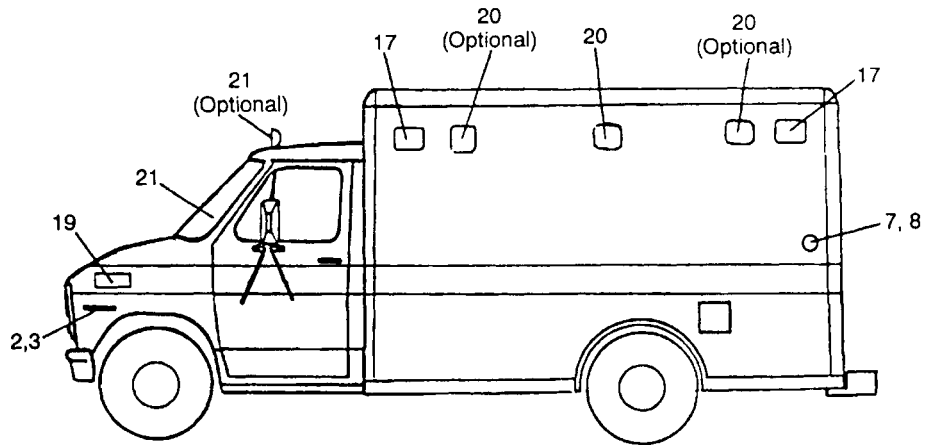

- | | |
|---|--|
| 1. Headlamp, (2) white [(4) white optional] | 13. Rear backup lamp, (1) white |
| *2. Front side marker lamp, (2) amber | 14. Rear license plate lamp, (1) white |
| 3. Front side reflector, (2) amber | 15. Front warning light, (2) red |
| 4. Front turn signal, (2) amber, (Includes vehicular hazard warning signal flasher) | 15a. Front warning light, (1) white |
| 5. Front identification lamps, (3) amber | 16. Rear warning light, (2) red |
| 6. Front clearance lamp, (2) amber | 16a. Rear warning light, (1) amber |
| *7. Rear side marker lamp, (2) red | 17. Side warning light, (2) red per side |
| 8. Rear side reflector, (2) red | 18. Grille light, (2) red |
| 9. Rear identification lamps, (3) red | 19. Intersection lights, (1) per side |
| 10. Rear clearance lamp, (2) red | 20. Side floodlight, (2) |
| 11. Rear reflector, (2) red | 20a. Rear floodlight, (1) |
| 12. Rear, stop, tail, lamp, (2) red | 21. Spotlight (white) (hand held) |
| 12a. Rear turn signal, (2) amber (includes vehicular hazard warning signal flasher) (optional location) | 21a. Spotlight (white) (optional location) |

*Flashes with front/rear turn signal & vehicular hazard warning signal flasher.

Lamps and reflectors may be mounted in other practicable locations provided location and visibility requirements of Federal Motor Vehicle Safety Standard No. 108 are met. The warning lights shown are for the standard warning light systems. The number of devices and their locations may be different in alternative warning light systems.

FIG. 4 Type III Ambulance

*Requires conversion of chassis to four wheel drive (4x4), (see 6.1.6).

Configuration A: Elevating cot and squad bench for ALS (see 6.1.5.1 and 6.11.4).

Configuration B: Elevating cot and squad bench for BLS (see 6.1.5.2).

1.3.3.1 *Type III—AD* (Additional Duty—with increased GVWR, storage, and payload capacity) A or B or neonatal, critical patient transport, or A or B with rescue, or fire suppression package, or both (see 6.1.4.1).

| Class | Configuration |
|---------------------------|---------------|
| Two rear driven (4 × 2) | A or B* |
| Four wheel driven (4 × 4) | A or B* |

*As specified by purchaser. The configuration shall provide for a neonatal, critical patient transport, configuration A or B with fire suppression package and rescue capability when specified.

1.4 *Order of Precedence*—In the event of a conflict between the text of this practice and the references cited herein, the text of this practice shall take precedence, except where required by law including Federal, State, and local laws and regulations.

1.5 The values stated in SI units are to be regarded as the standard. The values given in parentheses are for information only.

1.6 *This standard does not purport to address all of the safety concerns, if any, associated with its use. It is the responsibility of the user of this standard to establish appropriate safety and health practices and determine the applicability of regulatory limitations prior to use.*

2. Referenced Documents

2.1 ASTM Standards:

- B 117 Practice for Operating Salt Spray (Fog) Apparatus²
- F 920 Specification for Minimum Performance and Safety Requirements for Resuscitators Intended for Use With Humans³
- F 960 Specification for Medical and Surgical Suction and Drainage Systems⁴
- F 1177 Terminology Relating to Emergency Medical Services³
- F 1328 Guide for Training Emergency Medical Technician (Basic) to Prepare Patients for Medical Transportation³
- F 1517 Guide for Scope of Performance of Emergency Medical Services Ambulance Operations³
- F 1949 Specification for Medical Oxygen Delivery Systems for EMS Ground Vehicles³

2.2 Federal Specifications:⁵

- L-S-300 Sheeting and Tape, Reflective, Nonexposed Lens, Adhesive Backing
- RR-C-901/3 Cylinders Compressed Gas: With Valve or Plug and Cap; ICC3aa

2.3 Federal Standards:⁵

- Federal Standard No. 297**, Rustproofing of Automotive Vehicles

2.4 Military Standards:⁶

- MIL-STD-461** Requirements for the Control of Electromagnetic Interference Characteristics of Subsystems and Equipment
 - MIL-STD-1223** Nontactical Wheeled Vehicles, Painting, Identification Marking and Data Plate Standards
- ### 2.5 Laws and Regulations:⁷
- 21 CFR 820 Quality System Regulation (QSR) (FDA)
 - 29 CFR 1910 Occupational Safety and Health Administration (OSHA) Standards
 - 40 CFR 86 Control of Air Pollution from New Motor Vehicles and New Motor Vehicle Engines
 - 47 CFR, PART 90 Private and Land Mobile Radio Services; Sub Part B: Public Safety Radio Pool
 - 49 CFR 393** Federal Motor Carrier Safety Regulations (FMCSR)
 - 49 CFR 571 Federal Motor Vehicle Safety Standards (FMVSS)

2.6 *Other Publications*—The following documents form a part of this practice to the extent specified. Unless a specific issue is identified, the issue in effect on date of invitation for bids or request for proposal shall apply.

- American Heart Association* Standards and Guidelines for Cardiopulmonary Resuscitation (CPR) and Cardiac Care⁸
- State of California Motor Vehicle Code*⁹
- The Tire and Rim Association Inc. Yearbook*¹⁰
- Society of Automotive Engineers (SAE), Inc., Standards and Recommended Practices:*¹¹
- J163** Low Tension Wiring and Cable Terminals and Splice Clips
- J537** Storage Batteries
- J541 Voltage Drop for Starting Motor Circuits
- J551** Measurement of Electromagnetic Radiation from Motor Vehicles and Devices
- J553** Circuit Breakers
- J561** Electrical Terminals, Eyelet and Spade Type
- J575 Tests for Motor Vehicle Lighting Devices & Components
- J576** Plastic Materials, For Use In Optical Parts Such As Lenses and Reflectors of Motor Vehicle Lighting Devices
- J578** Color Specification for Electric Signal Lighting Devices
- J595 Flashing Warning Lamps for Authorized Emergency, Maintenance, and Service Vehicles
- J638 Test Procedure and Ratings for Hot Water Heaters for Motor Vehicles

⁶ Copies of Military Specifications and Standards required by suppliers in connection with specific procurement functions should be obtained from the procuring activity or as directed by the contracting officer.

⁷ Available from the Superintendent of Documents, U.S. Government Printing Office, Washington, DC 20402. When indicated, reprints of certain regulations may be obtained from the Federal agency responsible for issuance thereof.

⁸ *Circulation Magazine*, Vol 102, Number 8, Aug. 2, 2000 (Supplement 1—ECC Guidelines).

⁹ Available from Department of Motor Vehicles, 2570 24th St., Sacramento, CA 95809.

¹⁰ Application for copies should be addressed to The Tire and Rim Association, Inc., 175 Montrose W. Ave., Suite 150, Copley, OH 44321.

¹¹ Available from Technical Division, SAE, 400 Commonwealth Dr., Warrendale, PA 15096.

² *Annual Book of ASTM Standards*, Vol 03.02

³ *Annual Book of ASTM Standards*, Vol 13.02.

⁴ Discontinued; See 2001 *Annual Book of ASTM Standards*, Vol 13.01.

⁵ Copies of Federal Standards and Specifications are available from Federal Standards and Specifications, Superintendent of Documents, U.S. Government Printing Office, 732 N. Capital St., NW, Mail Stop: SDE, Washington, DC 20401.

- J639 Safety Practices for Mechanical Vapor Compression Refrigeration Equipment or Systems Used To Cool Passenger Compartment of Motor Vehicles
- J682 Rear Wheel Splash and Stone Throw Protection
- J683 Tire Chain Clearance
- J689 Approach, Departure, and Ramp Breakover Angles
- J771 Automotive Printed Circuits
- J845 Method for Determining the Flash Energy of a Light
- J858 Electrical Terminals, Blade Type
- J928 Electrical Terminals, Pin and Receptacle Type
- J994 Backup Alarms, Performance Test and Application
- J1054 Warning Lamp, Alternating Flashers
- J1127 Battery Cable
- J1128 Low Tension Primary Cable
- J1292 Automobile, Truck, Truck-Tractor, Trailer, and Motor Coach Wiring
- J1318 Strobe Warning Lights
- J1349 Engine Power Test Code, Spark Ignition and Diesel
- J2498 Minimum Performance of the Warning Light System Used on Emergency Vehicles
- National Truck Equipment Association/AMD:*¹²
- AMD Standard 001** Static Load for Ambulance Body Structure Test
- AMD Standard 002** Body Door Retention Components Test
- AMD Standard 003** Oxygen Tank Retention System Test (Main and Portable Cylinders)
- AMD Standard 004** Litter Retention System Test
- AMD Standard 005** Ambulance 12 Volt dc Electrical Systems Test
- AMD Standard 006** Sound Level Test Code
- AMD Standard 007** Carbon Monoxide Levels For Patient Compartment Interiors
- AMD Standard 008** Ambulance Patient Compartment Grab Rail (Load Test)
- AMD Standard 009** 120 VAC Electrical Systems
- AMD Standard 010** Water Spray Test
- AMD Standard 011** Ambulance Equipment Temperature Test
- AMD Standard 012** Temperature Tests
- AMD Standard 013** Weight Distribution Test
- AMD Standard 014** Cooling System Test
- AMD Standard 015** Ambulance Oxygen System Test

3. Terminology

3.1 Definitions:

3.1.1 *ambulance, n*—see 1.1.1.

3.2 For definitions of terms used in this practice, refer to Terminology **F 1177**.

4. Summary of Practice

4.1 The principle of this practice is to define the range of designs, features, performance characteristics for manufacturers, purchasers, and users, of “Star of Life” ambulances recommended for EMSS ambulance services.

5. Significance and Use

5.1 This document describes the practices for commercial ambulance manufacturers/vendors for:

5.1.1 Design and construction, and outfitting of a variety of EMSS ambulances designs using commercially available light truck vehicle chassis, fabricated vehicle bodies, and commercially available components and equipment.

5.1.2 Testing the performance of ambulances and equipment in accordance with nationally accepted ambulance manufacturers (AMD) test standards.

5.1.3 Outfitting and equipping ambulances with medical equipment as recommended by appropriate medical associations to meet needs specified by purchasers.

5.1.4 Certification of ambulances in accordance with “Star of Life” criteria.

5.1.5 Painting coloring and marking EMS ambulances in accordance with “Star of Life” standards preparatory to delivery to purchasers.

5.2 This document describes practices for ambulance purchasers for:

5.2.1 Preparation of a purchase description for the procurement of an EMSS ambulance in accordance with this practice, using guidance contained in Section 9.

5.2.2 Specifying ambulance inspections, tests and documentation preparatory to acceptance of delivery.

5.3 This document describes practices for ambulance users for:

5.3.1 Acquainting ambulance service medical directors with features of various ambulance designs and capabilities for planning purposes.

5.3.2 Acquainting ambulance service managers and operators (EMTs) with ambulance designs, equipment, and expected performance characteristics to enable them to safely operate EMS ambulances in accordance with Guide **F 1517**, and effectively prepare patients for medical transport in accordance with Guide **F 1328**.

5.4 *Standard Coverage*—This practice does not include all the varieties of medical service vehicles commercially available. This practice covers only the ambulances approved to display the “Star of Life” symbols and purchased to provide pre-hospital emergency medical services in accordance with provisions of other ASTM Committee F30 standards.

5.5 *Precautions and Observations*—Purchasers should read the entire document before requisitioning an ambulance, in order to be knowledgeable of just what equipment is standard, and which options need to be exercised. Due to the variety of ambulance equipment or features, some options may be incompatible with the model desired (reference chassis and ambulance manufacturer’s data books).

6. Requirements

6.1 *General Vehicular Design, Types, and Floor Plan:*

6.1.1 *Design*—The ambulance and the allied equipment furnished under this practice shall be the manufacturer’s current commercial vehicle of the type, class, and configuration specified. The ambulance shall be complete with the operating accessories, as specified herein. It shall be furnished with such modifications and attachments as may be necessary to enable

¹² Available from the Ambulance Manufacturer’s Division (AMD) of the National Truck Equipment Association, 37400 Hills Tech Dr., Farmington Hills, MI 48331.

the vehicle to function reliably and efficiently in sustained operation. The design of the vehicle and the specified equipment shall permit accessibility for servicing, replacement, and adjustment of component parts and accessories with minimum disturbance to other components and systems. The term “heavy-duty,” as used to describe an item, shall mean in excess of the standard quantity, quality, or capacity and represents the best, most durable, strongest, and so forth part, component, system, and so forth that is commercially available on the Original Equipment Manufacturer’s (OEM) chassis.

NOTE 2—Ambulance crash tests and analysis are being conducted to identify ambulance occupant crash injury mechanisms. Problems identified in these tests should lead to ambulance design changes in 6.4.1, 6.10.5, 6.10.6, 6.10.7, 6.10.8.1, and 6.11.3 which will prevent or reduce the severity of ambulance crash injuries. Appropriate changes, based on automotive crashworthiness principles will be incorporated in future changes to this practice.

6.1.2 *Type I Ambulance*—Type I vehicle, Class 1 or 2, Configuration A or B, shall be a chassis furnished with a 2-door enclosed cab. The chassis-cab shall be suitable for subsequent mounting of a transferable, modular, ambulance body conforming to the requirements specified herein. (See Fig. 2.)

6.1.2.1 *Type I—AD (Additional Duty) Ambulance*—Type I-AD, Class 1 or 2, Configuration A, B, or other user specified configurations such as for critical patient or neonatal transport, shall be a conventional truck, cab-chassis with modular body and increased GVWR, storage, and payload. Additionally, other on board systems or equipment may be specified for rescue or fire suppression or combination of applications. The chassis shall be suitable for mounting of a transferable modular ambulance body conforming to the requirements herein.

6.1.3 *Type II Ambulance*—Type II vehicle, Class 1 or 2, Configuration A or B, shall be OEM chassis manufacturer’s commercial, long wheel base, integral van. This vehicle shall be suitable for subsequent ambulance conversion/modification in compliance with the requirements herein (see Fig. 3.)

6.1.4 *Type III Ambulance*—Type III, Class 1 or 2, Configuration A or B shall be a “cutaway” van with a transferable, modular, ambulance body or unitized cab-body mounted on a chassis. The chassis with unitized cab-body or front section cab-chassis shall be suitable for the subsequent fabrication, conversion, or modification into an ambulance incorporating the requirements and the equipment specified herein. (See Fig. 4.)

6.1.4.1 *Type III—AD (Additional Duty) Ambulance*—Type III-AD, Class 1 or 2, or other user specified configurations, such as for critical patient or neonatal transport, shall be a cutaway cab-chassis with modular body, and increased GVWR, storage, and payload. Additionally, other onboard systems or equipment may be specified for rescue or fire suppression or combination of applications. The chassis shall be suitable for mounting of a transferable modular ambulance body conforming to the requirements herein.

6.1.5 *Configuration of Patient Compartment*—Unless otherwise specified (see 9.2.3), Configuration “B”, Basic Life Support (BLS) shall be provided in the patient compartment. All litters shall be loaded to position the patient’s head forward in the vehicle.

6.1.5.1 *Configuration “A” (ALS)*—When specified for Types I or III (see 9.2.2), Advanced Life Support (ALS) applications, one primary patient shall be on a wheeled elevating cot and a secondary patient lying on a folding stretcher or combination stretcher chair on the squad bench, or one primary patient and three secondary seated patients on the squad bench (see 6.11.4) and one seated EMT/paramedic. The primary cot shall be center mounted or, when specified (see Table 8, Item 21), a dual position mount shall be furnished. Unless otherwise specified (see Table 7, Item 28), a CPR seat conforming to all specification requirements shall be furnished on the left (street) side of the body facing the patient’s thoracic region and include a seat belt and padding at the EMT’s head region. Space shall also be furnished in the action wall/counter area for placement of a cardiac monitor/defibrillator. When specified (see Table 8, Item 25), a crash stable mounting bracket for securing the cardiac monitor/defibrillator shall be furnished. A locking drug kit compartment per Table 7, Item 14 and high intensity light per Table 7, Item 8 also shall be furnished. Two each I.V. hangers, per 6.11.9, shall be provided for the primary patient and the secondary patient, one at the patient’s head and one at the patient’s lower extremities.

6.1.5.2 *Configuration “B” (BLS)*—Unless otherwise specified (see 9.2.3), Configuration “B” shall provide for one primary patient on a wheeled elevating cot and one secondary patient on a folding stretcher or combination stretcher/chair on a squad bench, which is also capable of accommodating three seated patients (see 6.11.5) and one seated EMT (see 6.10.3).

NOTE 3—It is preferable that the primary patient’s cot be positioned on the left (street) side or centered in the ambulance patient compartment. The anatomy of the tracheal bronchial tree is such that an unconscious patient will be less likely to aspirate fluids into the trachea if placed on their left side with the right side up.

6.1.6 *Four Wheel Drive, Class 2, 4x4:*

6.1.6.1 When a 4x4 chassis is specified (see 9.2.2), the additional curb weight of the 4x4 chassis above the 4x2 chassis will reduce the payload proportionally. When available, a Class 2 ambulance shall be an original chassis manufacturer’s (OEM) 4x4 chassis for Type 1 ambulances, or an OEM 4x2 model with a professionally engineered conversion to a four wheel drive (4x4) conforming to all applicable requirements herein. All workmanship, welding, mechanical fit grade, and quality of components and materials used in conversions shall be equal to or greater than OEM manufacturer’s production 4x4 units. Conversion components shall not interfere with other body, chassis, or mechanical parts through the complete

TABLE 1 Wiring Criteria

| Circuit Breaker Rating, Amps | Minimum Wire Size For Circuit Rating and Voltage Drop |
|------------------------------|---|
| 10 | 16 |
| 15 | 14 |
| 20 | 12 |
| 30 | 10 |
| 40 | 8 |
| 50 | 6 |
| 75 | 4 |
| 100 | 2 |
| 125 | 0 |
| 150 | 00 |

TABLE 4 Ambulance Stretchers, Cots, and Litters

| Stretchers, Cots, and Litters | Dimensions, cm/in. | | |
|--|--------------------|--|---------------------------------|
| | Length, Minimum | Width, Minimum | Bed Height, Maximum (Collapsed) |
| Style 1—wheeled cot (elevating) | 191/75 | 56/22 | 38/15 ^A |
| Style 2—wheeled cot (elevating with additional front roll-in wheels) | 200/79 | 56/22 | 33/13 |
| Style 3—folding stretcher or combination stretcher chair | 189/73.5 | 48/19 | 21/8.25 |
| Style 4—navy stokes litter (resting on floor) | 215/84.75 | 60/23.5 | 19/7.5 |
| Style 5—standard army and NATO litters (with poles) ^B | 90 (+0, -¼) | 23 (+ ⁶ / ₁₀ , - ³ / ₄) | 17/6.75 |

^A Measured to top of positioned 7.6-cm (3-in.) thick mattress.

^B Dimensions of Army and NATO litters are in accordance with North Atlantic Treaty Organization Standardization agreement STANAG No. 2040.

TABLE 5 Minimum Interior Storage Requirements

| Item | Minimum Volume | |
|--|----------------|-------------|
| | Cubic Metres | Cubic Feet |
| Medicine dispensary cabinet(s) | 0.17 | 6 |
| Medical supplies cabinet | 0.25 | 9 |
| Linen supplies | 0.11 | 4 |
| Trash receptacle compartment and sharps disposal container | 0.06 | 2 |
| Oxygen installation (main) (see 6.12) | 0.17 | 6 |
| Oxygen unit (portable) | 0.06 | 2 |
| Telemetry equipment | 0.06 | 2 |
| Radio equipment & antenna | 0.03 | 1 |
| Storage, miscellaneous | 0.06 | 2 |
| Vacuum aspirator unit | 0.03 | 1 |
| Air conditioning unit | | as required |
| Heating system | | as required |

range of suspension and wheel angle travel and allow proper alignment of axles. The tracking and wheelbase of the front/rear axles shall be identical on both sides of the vehicle. When available, the chassis manufacturer's OEM components used on the chassis manufacturer's other models with the same or greater GAWRs and GVWRs shall be furnished, including but not limited to: spring hangers, shackles, drive axle, integral transmission/transfer case, universal joints, steering linkage, stabilizer bars, radius and torque rods, transfer case shaft linkage, brake calipers, pads, rotors, shock absorbers and springs. When available, the chassis manufacturer's guidelines/requirements for 4x4 conversions shall be followed. The design of the 4x4 conversion shall minimize the height of the vehicle's chassis. The 4x4 converter shall include a complete chassis modifier FMVSS certification and sticker.

6.1.6.2 The 4x4 converter shall provide to the purchaser a full parts and labor warranty covering all added 4x4 parts and materials, including workmanship and design. The warranty shall also cover all OEM components affected or modified by the conversion process. This warranty shall be at least equivalent, in mileage and time, to the OEM chassis manufacturer's warranty, including any extended warranties required or furnished.

6.1.6.3 Accompanying each conversion shall be complete manuals showing operation, maintenance, and repair procedures, chassis manufacturer's part numbers, drawings for components used in the conversion, and dimensioned drawings for manufactured parts, alignment procedures, and specifications.

6.2 *Vehicle Ambulance Components, Equipment, and Accessories*—The emergency medical care vehicles, including chassis, ambulance body, equipment, device, medical accesso-

ries, and electronic equipment shall be standard commercial products, tested and certified to meet or exceed the requirements of this practice. The ambulance shall comply with all Federal Motor Vehicle Safety Standards (FMVSS) and other federal and state regulations applicable or specified for the year of manufacture. The chassis, components, and optional items shall be as represented in the chassis manufacturers current technical data. The ambulance body, equipment, and accessories shall be as represented in their respective manufacturer's current technical data. Data shall be limited to specifications and technical materials identical to that furnished to the authorized company representatives and shall be furnished to the engineering/technical offices of the procuring activity and the suppliers (contractor's) offices prior to acceptance of the ambulance. The supplier shall provide total standardization and interchangeability between similar vehicles, equipment, items, and accessories specified for all ambulance units under each contract.

6.3 *Recovered Materials*—All equipment, material, and articles required under this practice are to be new or fabricated from new materials produced from recovered materials. The term "recovered materials" means materials that have been collected or recovered from solid waste and reprocessed to become a source of raw materials, as opposed to virgin raw materials. None of the above shall be interpreted to mean that the use of used or rebuilt products is allowed under this practice.

6.4 *Vehicle Operation, Performance, and Physical Characteristics*:

6.4.1 *Operation and Performance*—Unless otherwise specified by the purchaser, all requirements in 6.4 shall be met with the ambulance loaded to meet or exceed the minimum specified payload including all specified equipment and devices installed and operating at the maximum power-consuming condition, for example, air conditioning, lights, radio(s), and so forth, with the chassis performing in accordance with the specified chassis manufacturer's technical data. The vehicle shall be capable of operating safely and efficiently under environmental conditions outlined herein or as specified in the invitation for bid, contract, or order. When specified by the purchaser for ambulances requiring higher GVWRs to carry additional specialty equipment, for example, medical; rescue; neonatal; (see 9.2.4), lower performance levels are acceptable in 6.4.6-6.4.8.2.

6.4.2 *Temperature Conditions*—The ambulance, including all required systems, equipment, and medical devices (except when medical devices are regulated by another agency) furnished inside the ambulance, when serviced and maintained in

accordance with the OEM manufacturer's recommendations (7.4), shall be capable of being stored without damage or deterioration in ambient temperatures of -34 to 52°C (-30 to 125°F). Testing shall be in accordance with AMD Standard 011 (Ambulance Equipment Temperature Test). Medical devices, such as resuscitation and suctioning apparatus, shall be cold tested for the required flow performance on 12-V dc vehicle power and 115 V ac power modes (see 6.12.1.1). Type certification from medical and other equipment manufacturers is acceptable.

6.4.3 *Noise and Sound Level Limits, Exterior*—Unless more stringent sound levels are regulated by the states and municipalities where the ambulance will be based, the exterior noise level produced by the vehicle, except siren, shall not exceed federal regulations.

6.4.4 *Vehicle Performance*—The ambulance shall provide a smooth, stable ride with minimum noise and without abnormal vibration. The ambulance to be certified shall be tested under conditions of 7.4.4.

NOTE 4—ASTM Task Group F30.01.01 recognizes this practice is weak with respect to provisions regarding shock, and vibration. It was previously proposed that this practice be changed by referencing two additional SAE Standards J1490 J1739; however, it was determined that these standards were not applicable. It is noted that with the exception of requirements for vibration, acceleration, and shock testing of ambulance oxygen system components required in Specification F 1949, this practice lacks performance and test requirements for shock and vibration. Task Group F30.01.02 on Air Ambulances currently is considering application of provisions of MIL-STD-810F for air ambulances. When the air ambulance standards are updated, it is planned that applicable improvements in the air ambulance standards will be proposed as changes in this practice.

6.4.5 *Brakes*—The ambulance braking system as delivered to the user shall comply to performance values required by Federal Motor Vehicle Safety Standards (FMVSS), and when available from the chassis manufacturer shall include ABS.

6.4.6 *Speed*—The vehicles shall be capable of a sustained speed of not less than 105 km/h (65 mph) over dry, hard surfaced, level roads, at sea level, and passing speeds of 113 km/h (70 mph) when tested under normal ambient conditions.

6.4.7 *Acceleration*—Vehicle shall have a minimum average acceleration, at sea level, of 0 to 88 km/h (0 to 55 mph) within 25 s. Test shall be performed under normal ambient conditions. Test under 7.4.4.

6.4.8 *Gradeability*—At full payload, the vehicle shall be capable of meeting the following requirements. The determination shall be made by actual test or chassis manufacturer's certified computer prediction or chassis manufacturer's certification.

6.4.8.1 *Gradeability at Speed*—Minimum gradeability at speed shall be 89 km/h (55 mph) on a 3 % (1.72°) grade.

6.4.8.2 *Minimum Low Speed Gradeability*—The minimum low speed gradeability of 8 km/h (5 mph) on a 35 % (19.3°) grade is required for Class I (4x2) vehicles and 45 % (24.2°) grade for Class 2 (4x4) vehicles in the low 4x4 range.

6.4.9 *Fuel Range*—Unless otherwise specified (see 9.2.5), the ambulance shall be capable of being driven for at least 402 km (250 miles) without refueling under the conditions in 7.4.4.

6.4.10 *Fording*—The vehicle shall be capable of three fordings, without water entering patient and equipment compartments while being driven through a minimum of 20 cm (8 in.) of water, at speeds of 8 km/h (5 mph), for a distance of at least 30.5 m (100 ft). Test under 7.4.4.

6.4.11 *Vehicle Physical Dimensional Requirements:*

6.4.11.1 *Length*—Overall length of the ambulance shall not exceed 671 cm (22 ft), including bumpers, but excluding rear step and bumper guards. Purchaser may specify (see 9.2.6) additional length if necessary to accommodate special equipment or larger bodies and crew cabs but should consult with the manufacturer to determine that other safety/handling, and functional characteristics are not compromised.

6.4.11.2 *Width*—Unless otherwise specified (see 9.2.7), the overall (OA) width of ambulance bodies having single rear wheels shall be between 200 and 213 cm (79 and 84 in.), excluding mirrors and lights. The ambulance body sides, on a chassis with dual rear wheels, shall be within ± 6.35 cm (± 2.5 in.) of the overall width of the tires (outside sidewalls) (see 6.5.6, 6.6.5.8, and 6.9.7). Tires shall not extend beyond the fenders. Unless approved by the purchaser and permitted by state laws, the maximum ambulance body width shall not exceed 244 cm (96 in.), excluding mirrors, lights, and other safety appurtenances. The wide track axle shall be furnished on dual rear wheeled vehicles, unless a narrow ambulance body is specified by the purchaser (see 9.2.7).

6.4.11.3 *Height*—Unless otherwise specified (see 9.2.8), overall height of the ambulance at curb weight (see 6.5.1) shall not exceed 279 cm (110 in.), including roof mounted equipment, but excluding two-way radio antenna(s).

6.4.11.4 *Ground Clearance*—With the exception of the chassis manufacturer's furnished and installed components, the lowest part of the vehicle, when loaded to the Gross Vehicle Weight Rating (GVWR), shall have a minimum of 20 cm (8 in.) of ground clearance, and 15 cm (6 in.) for chassis-mounted components.

6.4.11.5 *Angle of Approach, Ramp Breakover, and Departure*—With the exception of the chassis manufacturer's furnished and installed components, the ambulance, loaded to the GVWR, including payload, (see 6.5.2) with bumpers and rear step (down if folding style), shall provide not less than the following clearance, measured in accordance with SAE J689.

Approach angle = 20°

Ramp breakover = 10°

Departure angle = 10°

6.4.11.6 *Turning Radius*—Shall not be greater than chassis OEM standard.

6.4.11.7 *Floor Height*—The finished floor (loading) heights shall not exceed 84 cm (33 in.) on Class I (4x2) vehicles and 97 cm (38 in.) for Class 2 (4x4) vehicles. The height shall be measured at curb weight plus full payload but minus patients and personnel. The use of an automotive "dump valve" on air suspension vehicles is acceptable to achieve the loading height requirement. The system shall include an interlock that only permits vehicle lowering when the vehicle is in neutral or park, and the parking brake is set.

6.5 *Vehicle Weight Ratings and Payload:*

6.5.1 *Curb Weight*—Curb weight is the total weight of the complete ambulance and is defined as: chassis (including batteries, spare tire, jack tire changing tools), cab, body, minimum required equipment per this practice, and a full complement of fuel, lubricants, and coolant, excluding optional equipment in 6.15.3 and 6.15.4, and any nonportable vehicle mounted rescue (extrication) equipment, permanently mounted fire suppression system and equipment including nozzles, hoses, tanks, pumps, and so forth and including a full complement of water and related foam, chemicals, and so forth.

6.5.2 *Payload Allowance*—Each vehicle’s payload allowance shall be determined and displayed in accordance with the weight/payload certification form (sticker) (see Fig. 5). Sticker shall be located in a conspicuous location in the vehicle. Payload shall be over and above the specified curb weight (see 6.5.1) of the vehicle and include specified options, miscellaneous medical equipment, and communications equipment that is appropriately distributed within the vehicle. The usable payload for additional duty modular Type I-AD or Type III-AD (with increased GVWR, for example, 14 000 lbs) ambulances

shall be specified by the customer. (**Warning**—Because of potential hazards and damage to vehicle’s chassis, the ambulance shall not be overloaded. The purchaser should consult with the ambulance and chassis manufacturer(s) or both to determine actual reserve capacity above the specified minimum required herein.) Unless additional payload is specified (see 9.2.9) by the purchaser, the required minimum payload per vehicle shall be as follows:

6.5.2.1 Single, rear wheeled, modular (Type I or III)—680 kg (1500 lbs)

6.5.2.2 Single, rear wheeled, van ambulances (Type II)—771.11kg (1700 lbs)

6.5.2.3 Dual, rear wheeled, modular ambulances (Type I or III)—793.79 kg (1750 lbs)

6.5.2.4 Additional Duty Modular Ambulances (Type I)—payload as specified by customer. The payload shall be evenly distributed throughout the vehicle and shall consist of the following:

(a) Driver and EMT at 79 kg (175 lbs) each (see Fig. 5).

(b) Two patients at 79 kg (175 lbs) each.

| PAYLOAD ALLOWANCE CERTIFICATION | |
|---|------------------|
| NOTICE: THIS VEHICLE, AS MANUFACTURED, CONFORMS TO THE PAYLOAD REQUIREMENTS OF THE ASTM STANDARD PRACTICE FOR EMSS AMBULANCES. USERS SHALL NOTLOAD VEHICLE ABOVE THE GVWR. USERS SHOULD DETERMINE THAT THE ACTUAL LOAD TO BE PLACED ON THE VEHICLE DOES NOT EXCEED THE USABLE PAYLOAD. | |
| Ambulance Manufacturer's Name | _____ |
| Chassis Model, Year of Manufacture | _____ |
| 1. Vehicle Type and Class | _____ |
| 2. Chassis Manufacturer GAWR-Front | _____ kg.(lbs.) |
| 3. Chassis Manufacturer GAWR Rear | _____ kg.(lbs.) |
| 4. Chassis Manufacturer GAWR | _____ kg. (lbs.) |
| 5. Minimum Payload As Specified. (Section 6.5.2) | _____ kg.(lbs.) |
| 6. Curb Weight-Front Base Vehicle | _____ kg.(lbs.) |
| 7. Curb Weight-Rear Base Vehicle | _____ kg.(lbs.) |
| 8. Curb Weight Base Vehicle (Item 6 Plus Item 7) (Section 6.5.1) | _____ kg.(lbs.) |
| 9. Payload of Basic Vehicle (Item 4 Minus Item 8) Must Meet Or Exceed item 5. | _____ kg.(lbs.) |
| 10. Total Weight of Options as Specified on Vehicle | _____ kg.(lbs.) |
| 11. REMAINING USABLE PAYLOAD (ACTUAL WEIGHT USER MAY ADD) (Item 9 Minus item 10) | _____ kg.(lbs.) |
| CAUTION: | |
| THIS STICKER/PLATE SHALL BE MOUNTED ON THE BODY (MODULE) IN A CONSPICUOUS LOCATION. | |
| The certification sticker is shown here as a suggested format. Deviations In dimensions are acceptable. All text must be included in manufacturer's sticker. | |

FIG. 5 Payload Allowance Certification

(c) Main and portable oxygen cylinders, stretchers, cots, and patient handling equipment.

(d) Portable, removable, medical devices.

(e) Durable and disposable medical items.

(f) Optional vehicle equipment such as battery charger, inverter, or any other optional items or equipment not supplied as a base vehicle requirement.

(g) Communications equipment.

(h) Extrication and rescue equipment.

(i) Portable fire extinguishers in addition to units required in 6.15.2 as specified by purchaser.

6.5.3 Gross Vehicle Weight Rating (GVWR)—The ambulance gross vehicle weight rating shall equal or exceed the combination of the vehicle's curb weight and payload weight. The chassis manufacturer's rating label shall show the actual gross vehicle weight rating (GVWR) and the gross axle weight rating (GAWR) of the vehicle (see 6.19).

6.5.4 Weight Distribution—To provide for maximum safety, purchasers and manufacturers shall locate vehicle-mounted components, equipment, and supplies to provide a vehicle that is laterally balanced and has front/rear loading that is proportional to axle ratings. The weight distribution of a properly loaded ambulance on a level surface shall permit conformance to the braking requirements in FMVSS 105 and for air brake vehicles FMVSS 121. The right and left wheel of each axle, at curb weight, (see 6.5.1) of a completed ambulance, shall be weighed to determine weight distribution. The weight between the right and left side of a given axle, when on a level surface, shall be within 5 % when calculated in accordance with 7.4.3.1 and tested in accordance with AMD Standard 013 (Weight Distribution Test). The ambulance manufacturer shall locate the center of gravity (CG) of the ambulance/ambulance body to determine and assure the purchaser that the CG of the completed ambulance does not exceed the maximum limits set by the chassis manufacturer. To meet the above weight distribution requirements, consideration shall be given by the purchaser and manufacturer to locate equipment and components to permit inherently proper lateral balance, front/rear axle loading, and center of gravity. (**Warning**—Ambulance purchasers and manufacturers should pay particular attention to the front/rear weight distribution of the vehicle in order to maximize handling characteristics, traction, and braking performance. Weight distribution should be proportional to the front and rear GAWRs.)

6.5.5 Ratings—Vehicle and component ratings shall be the chassis manufacturer's published ratings and shall not be raised above the chassis manufacturer's rating. When ratings are not published or chassis has been modified, the verification data of the component manufacturer's rating shall be made available to the appropriate offices of the procuring activity.

6.5.6 Cab to Axle (CA), Type I and III Vehicles—Cab to axle (CA) dimension of the vehicle chassis shall permit a minimum of 50 % of the outside body length (including cab extensions) forward of the rear axle centerline, plus cab to body clearance. Bodies designed with wheel openings shall have the rear wheels centered, ± 5 cm (2 in.) longitudinally, within the opening, and ± 13 mm (0.5 in.) laterally.

6.6 Chassis Power Unit, and Components:

6.6.1 Chassis Frame—The chassis shall include the chassis manufacturer's ambulance component package or, if not available, chassis manufacturers heavy-duty components that will enhance vehicle's reliability, durability, safety, and comfort. The chassis frame and components shall be constructed to withstand the strains of on-off road service and any special service and equipment requirements specified herein. All chassis (including cab) components shall be as represented in the chassis manufacturer's technical data.

6.6.2 Vehicle Lubrication—The chassis components, devices, accessories, and added equipment requiring lubrication shall be fully equipped with lubrication fittings, as provided by the chassis or equipment manufacturer.

6.6.3 Power Unit, Engines:

6.6.3.1 Power Unit—The power unit shall meet or exceed the required vehicle performance specified herein (see 6.4), at not more than the engine manufacturer's recommended operating engine speed. It shall be of such design and construction that it will provide a smooth flow of power, at all rpms, without undue vibration, strain, or overheating of engine parts.

6.6.3.2 Engine Low Temperature Starting—The engine shall start satisfactorily without the aid of preheating devices (except glow plugs) at -12°C (10°F), for the diesel engine and -28.9°C (-20°F) when a gasoline engine is specified (see 9.2.10). When specified by the purchaser, auxiliary engine/battery heating and starting devices, or both shall be provided to meet other starting requirements. Verification test to be performed during environmental test.

6.6.3.3 Power Plant Heaters, Minimum -34°C (-30°F) Startability—In addition to the chassis manufacturers standard block heater on diesel engines, when specified (see Table 7, Item 16), the manufacturer's standard power plant heater(s) (coolant or immersion type crankcase heaters and battery heaters) shall be furnished for the gasoline engine, which limits starting an engine at -34°C (-30°F).

6.6.3.4 Diesel Engine—The chassis manufacturer's highest horsepower/displacement diesel engine and power train shall be provided, complying with requirements of 6.4. Net horsepower rating shall conform to SAE J1349. Additionally, the chassis manufacturer's block heater shall also be furnished. For type AD vehicles the power train shall meet the performance requirements specified herein or as specified or approved by the purchaser.

6.6.3.5 Gasoline Engine—When specified (see 9.2.10), a gasoline engine shall be furnished which permits warranted operation on unleaded gasoline, when operated in accordance with OEM's manual. When specified (see 9.2.50) or required for export, the vehicle shall be capable of warranted operation on either leaded or unleaded gasoline. Engine horsepower end torque requirements shall be sufficient to comply with the requirements specified in 6.4. Net horsepower ratings shall conform to SAE J1349. Vehicle(s) being offered/supplied with catalytic converters shall be identified to all purchasers.

NOTE 5—Purchasers should be aware that, because of the severe operating conditions to which an ambulance is exposed, the use of a gasoline engine results in substantially higher underhood and under vehicle temperatures which could seriously impact vehicle reliability, dependability, safety, and may result in some manufacturer's chassis warranty being voided.