



SLOVENSKI STANDARD

SIST EN 14802:2006

01-april-2006

Plastics piping systems - Thermoplastics shafts or risers for inspection chambers and manholes - Determination of resistance against surface and traffic loading

Plastics piping systems - Thermoplastics shafts or risers for inspection chambers and manholes - Determination of resistance against surface and traffic loading

Kunststoff-Rohrleitungssysteme - Kontrollschächte (Inspektionsöffnungen) und Einsteigschächte aus Thermoplasten - Bestimmung der Widerstandsfähigkeit gegen Belastungen der Oberfläche und Verkehrslasten

[SIST EN 14802:2006](https://standards.iteh.ai/catalog/standards/sist/87e8906-f663-4479-a81a-1502ad2ec4/sist-en-14802-2006)

Systemes de canalisations en plastique - Elements de rehausse en thermoplastiques pour boîtes d'inspection et de branchement ou regards - Détermination de la résistance aux charges de remblai et de circulation

Ta slovenski standard je istoveten z: EN 14802:2005

ICS:

23.040.20	Cevi iz polimernih materialov	Plastics pipes
93.025	Zunanji sistemi za prevajanje vode	External water conveyance systems
93.030	Zunanji sistemi za odpadno vodo	External sewage systems

SIST EN 14802:2006

en

iTeh STANDARD PREVIEW
(standards.iteh.ai)

SIST EN 14802:2006

<https://standards.iteh.ai/catalog/standards/sist/f87e8906-f663-4479-a81a-156f2acd2ec4/sist-en-14802-2006>

EUROPEAN STANDARD

EN 14802

NORME EUROPÉENNE

EUROPÄISCHE NORM

December 2005

ICS 93.025; 93.030

English Version

Plastics piping systems - Thermoplastics shafts or risers for inspection chambers and manholes - Determination of resistance against surface and traffic loading

Systèmes de canalisations en plastique - Eléments de rehausse en thermoplastiques pour boîtes d'inspection et de branchement ou regards - Détermination de la résistance aux charges de remblai et de circulation

Kunststoff-Rohrleitungssysteme - Kontrollschächte (Inspektionsöffnungen) und Einsteigschächte aus Thermoplasten - Bestimmung der Widerstandsfähigkeit gegen Belastungen der Oberfläche und Verkehrslasten

This European Standard was approved by CEN on 4 November 2005.

CEN members are bound to comply with the CEN/CENELEC Internal Regulations which stipulate the conditions for giving this European Standard the status of a national standard without any alteration. Up-to-date lists and bibliographical references concerning such national standards may be obtained on application to the Central Secretariat or to any CEN member.

This European Standard exists in three official versions (English, French, German). A version in any other language made by translation under the responsibility of a CEN member into its own language and notified to the Central Secretariat has the same status as the official versions.

CEN members are the national standards bodies of Austria, Belgium, Cyprus, Czech Republic, Denmark, Estonia, Finland, France, Germany, Greece, Hungary, Iceland, Ireland, Italy, Latvia, Lithuania, Luxembourg, Malta, Netherlands, Norway, Poland, Portugal, Slovakia, Slovenia, Spain, Sweden, Switzerland and United Kingdom.



EUROPEAN COMMITTEE FOR STANDARDIZATION
COMITÉ EUROPÉEN DE NORMALISATION
EUROPÄISCHES KOMITEE FÜR NORMUNG

Management Centre: rue de Stassart, 36 B-1050 Brussels

EN 14802:2005 (E)

Contents	Page
Foreword	3
1 Scope	4
2 Normative references.....	4
3 Terms and definitions	4
4 Principle	5
5 Apparatus	5
6 Number of test pieces	7
7 Conditioning and test temperatures	7
8 Procedure	7
9 Test parameters	8
10 Test report	8

iTeh STANDARD PREVIEW
(standards.iteh.ai)

[SIST EN 14802:2006](#)

<https://standards.iteh.ai/catalog/standards/sist/f87e8906-f663-4479-a81a-156f2acd2ec4/sist-en-14802-2006>

Foreword

This European Standard (EN 14802:2005) has been prepared by Technical Committee CEN/TC 155 "Plastics piping systems and ducting systems", the secretariat of which is held by NEN.

This European Standard shall be given the status of a national standard, either by publication of an identical text or by endorsement, at the latest by June 2006, and conflicting national standards shall be withdrawn at the latest by June 2006.

The relevant performance requirements are contained within the referring standard(s) concerned.

This European Standard is one of a series of standards on test methods that support system standards for plastics piping systems and ducting systems.

According to the CEN/CENELEC Internal Regulations, the national standards organizations of the following countries are bound to implement this European Standard: Austria, Belgium, Cyprus, Czech Republic, Denmark, Estonia, Finland, France, Germany, Greece, Hungary, Iceland, Ireland, Italy, Latvia, Lithuania, Luxembourg, Malta, Netherlands, Norway, Poland, Portugal, Slovakia, Slovenia, Spain, Sweden, Switzerland and United Kingdom.

iTeh STANDARD PREVIEW (standards.iteh.ai)

[SIST EN 14802:2006](https://standards.iteh.ai/catalog/standards/sist/f87e8906-f663-4479-a81a-156f2acd2ec4/sist-en-14802-2006)

<https://standards.iteh.ai/catalog/standards/sist/f87e8906-f663-4479-a81a-156f2acd2ec4/sist-en-14802-2006>

EN 14802:2005 (E)**1 Scope**

This European Standard specifies a method of testing the resistance of the upper assembly of inspection chambers and manhole components against surface and traffic loading.

It does not include requirements for testing the cover and frame. These requirements are specified in EN 124 or other standards depending on the material.

NOTE 1 Upper assembly components would normally include riser shafts, tapers, reducing slabs and telescopic joints.

NOTE 2 This test method is intended to support prEN 13598-2 and prEN 15229 (see bibliography)

2 Normative references

The following referenced documents are indispensable for the application of this European Standard. For dated references, only the edition cited applies. For undated references, the latest edition of the referenced document (including any amendments) applies.

EN 124, *Gully tops and manhole tops for vehicular and pedestrian areas — Design requirements, type testing, marking, quality control*

ENV 1046, *Plastics piping and ducting systems — Systems outside building structures for the conveyance of water or sewage — Practices for installation above and below ground*

EN 1437, *Plastics piping systems — Piping systems for underground drainage and sewerage — Test method for resistance to combined temperature cycling and external loading*

[SIST EN 14802:2006](https://standards.iteh.ai/catalog/standards/sist/f87e8906-f663-4479-a81a-156f2acd2ec4/sist-en-14802-2006)

[https://standards.iteh.ai/catalog/standards/sist/f87e8906-f663-4479-a81a-](https://standards.iteh.ai/catalog/standards/sist/f87e8906-f663-4479-a81a-156f2acd2ec4/sist-en-14802-2006)

[156f2acd2ec4/sist-en-14802-2006](https://standards.iteh.ai/catalog/standards/sist/f87e8906-f663-4479-a81a-156f2acd2ec4/sist-en-14802-2006)

3 Terms and definitions

For the purposes of this European Standard, the following terms and definitions apply.

3.1**inspection chamber**

drainage or sewerage fitting used to connect drainage or sewerage installations and/or to change the direction of drainage or sewerage runs, which terminates at ground level and has a riser shaft with a minimum outer diameter of 200 mm and an inner diameter of less than 800 mm (see also EN 476:1997 for non-circular chambers)

NOTE The termination at ground level permits the introduction of cleaning, inspection and test equipment and the removal of debris but does not provide access for personnel.

3.2**manhole**

drainage or sewerage fitting used to connect drainage or sewerage installations and/or to change the direction of drainage or sewerage runs, which terminates at ground level and has a riser shaft with a minimum inner diameter of 800 mm (see also EN 476:1997 for non circular manholes)

NOTE The termination at ground level permits the introduction of cleaning, inspection and test equipment and the removal of debris and provides access for personnel.

4 Principle

A test assembly comprising at least the top 1 m of chamber or manhole components measured from and including any component or recommended installation assembly detail at the top end of the inspection chamber or manhole, is buried either in a soil box or under field conditions and a load is applied (see Figure 1).

During loading, the vertical displacement of the cover assembly is measured. After the test is finished, the test assembly is visually inspected and checked for defects.

NOTE The standard making reference to this European Standard can require test conditions that differ from those set in this European Standard for the following test parameters:

- a) the number of test pieces (see Clause 6);
- b) the maximum load (see Clause 9);
- c) the soil group of granular surround (see Clause 9);
- d) the compaction of the granular surround (see Clause 9).

5 Apparatus

5.1 Soil box, large enough to accommodate at least the first 1 m of the test assembly and such that at all sides of the assembly a free space of 300 mm minimum is available. The box shall conform to the rigidity and other general requirements specified in EN 1437.

5.2 Loading device, capable of applying the required load to the middle of the cover and of maintaining a constant load for a minimum of 15 min. The load shall be applied via a loading plate conforming to the requirements given in EN 124.

NOTE A loading device could comprise a hydraulic actuator, alternatively the load can be applied using dead weight.

5.3 Thermo-couple, capable of measuring temperature to an accuracy of ± 5 °C.

5.4 Test assembly, comprising at least the first 1 m of test assembly measured from and including the top assembly detail of the inspection chamber or manhole (see Figure 1).

EN 14802:2005 (E)

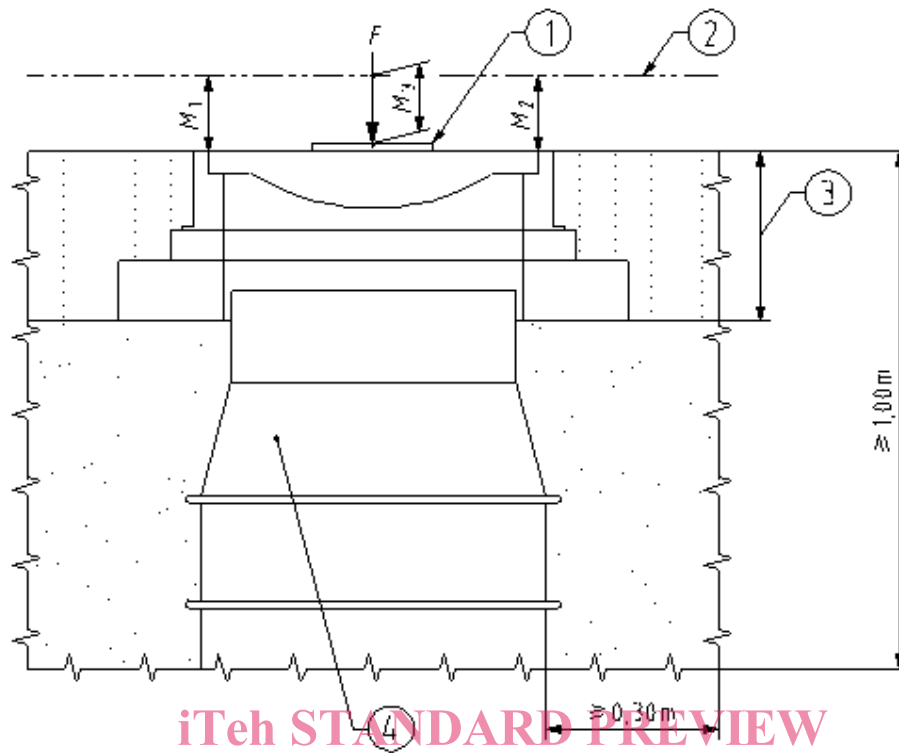
**Key**

- 1 loading plate, size according to EN 124
 - 2 reference line, datum
 - 3 cover-solution
 - 4 top element of chamber or manhole
- M_1 , M_2 and M_3 dimensions for determining the displacement (see 8.2)
- F test load

iTeh STANDARD PREVIEW
(standards.iteh.ai)

SIST EN 14802:2006

<https://standards.iteh.ai/catalog/standards/sist/f87e8906-f663-4479-a81a-156f2acd2ec4/sist-en-14802-2006>

Figure 1a — Test assembly

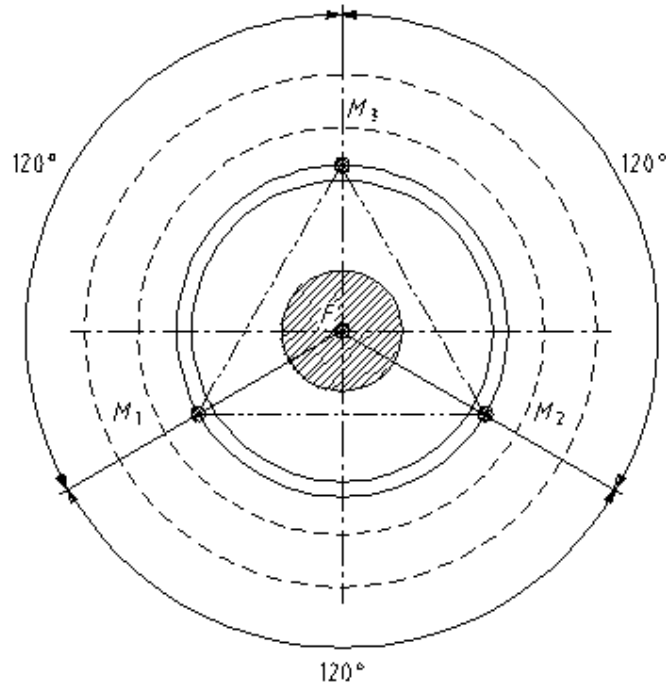

Key
 M1, M2 and M3 points of measurement of displacements
 F centre point of application of the test load

Figure 1b — Position of measuring points

SIST EN 14802:2006

6 Number of test pieces

<https://standards.iteh.ai/catalog/standards/sist/f87e8906-f663-4479-a81a-156f2acd2ec4/sist-en-14802-2006>

Unless otherwise specified in the referring standard, the number of test pieces shall be one.

7 Conditioning and test temperatures

The test pieces shall not be tested for at least 24 h after manufacture.

The test shall be performed at ambient temperature between 5 °C and 25 °C. The test shall not be performed if the granular surround is at a temperature of less than 3 °C. The temperature of the granular surround shall be recorded.

8 Procedure

8.1 Bury the test assembly (5.4) either in the soil box (5.1) or under field conditions using the test parameters given in Table 1 ensuring that there is at least 300 mm of specified granular surround conforming to Clause 9. Where the test assembly is to be buried in the field, excavate enough soil to accommodate at least the first metre of the riser shaft below the test assembly. Bury the thermo-couple in the granular surround at the top of the riser shaft, but below the other assembly components, at a distance of approximately 300 mm.

Where the inspection chamber or manhole incorporates a pavement as an integral part of the cover, apply the pavement as in real practice and bury under field conditions.

Where telescopic joints are supplied, install the support ring and covers in accordance with the manufacturer's product or installation description.