



SLOVENSKI STANDARD

SIST EN 14399-3:2005

01-maj-2005

J]gc_c]fXbcg]bY`g]fi _]hi fbY`j]U bY`nj YnY`nUdfYXbUdYhY`!" "XY.`G]ghYa `<F`!
Nj YnY`j]U_cj `g`yYg]fcVc [`Uj c `]b`yYg]fcVc`a U]W

High-strength structural bolting assemblies for preloading - Part 3: System HR - Hexagon bolt and nut assemblies

Hochfeste planmäßig vorspannbare Schraubenverbindungen für den Metallbau - Teil 3: System HR - Garnituren aus Sechskantschrauben und -muttern

Boulonnerie de construction a haute résistance apte a la précontrainte - Partie 3 : Systeme HR - Boulons a tete hexagonale (vis + écrou)

<https://standards.iteh.ai/catalog/standards/sist/87b9dee7-ec1c-4d8b-9b5f-788d9b1eaa3b/sist-en-14399-3-2005>

Ta slovenski standard je istoveten z: EN 14399-3:2005

ICS:

21.060.10	Sorniki, vijaki, stebelni vijaki	Bolts, screws, studs
21.060.20	Matice	Nuts

SIST EN 14399-3:2005

en

iTeh STANDARD PREVIEW
(standards.iteh.ai)

SIST EN 14399-3:2005

<https://standards.iteh.ai/catalog/standards/sist/87b9dee7-ec1c-4d8b-9b5f-788d9b1eaa3b/sist-en-14399-3-2005>

EUROPEAN STANDARD

EN 14399-3

NORME EUROPÉENNE

EUROPÄISCHE NORM

March 2005

ICS 21.060.10; 21.060.20

English version

High-strength structural bolting assemblies for preloading - Part 3: System HR - Hexagon bolt and nut assemblies

Boulonnerie de construction métallique à haute résistance
apte à la précontrainte - Partie 3 : Système HR - Boulons à
tête hexagonale (vis + écrou)

Hochfeste planmäßig vorspannbare
Schraubenverbindungen für den Metallbau - Teil 3: System
HR - Garnituren aus Sechskantschrauben und -muttern

This European Standard was approved by CEN on 30 April 2004.

CEN members are bound to comply with the CEN/CENELEC Internal Regulations which stipulate the conditions for giving this European Standard the status of a national standard without any alteration. Up-to-date lists and bibliographical references concerning such national standards may be obtained on application to the Central Secretariat or to any CEN member.

This European Standard exists in three official versions (English, French, German). A version in any other language made by translation under the responsibility of a CEN member into its own language and notified to the Central Secretariat has the same status as the official versions.

CEN members are the national standards bodies of Austria, Belgium, Cyprus, Czech Republic, Denmark, Estonia, Finland, France, Germany, Greece, Hungary, Iceland, Ireland, Italy, Latvia, Lithuania, Luxembourg, Malta, Netherlands, Norway, Poland, Portugal, Slovakia, Slovenia, Spain, Sweden, Switzerland and United Kingdom.

[SIST EN 14399-3:2005](https://standards.iteh.ai/catalog/standards/sist/87b9dee7-ec1c-4d8b-9b5f-788d9b1eaa3b/sist-en-14399-3-2005)

<https://standards.iteh.ai/catalog/standards/sist/87b9dee7-ec1c-4d8b-9b5f-788d9b1eaa3b/sist-en-14399-3-2005>



EUROPEAN COMMITTEE FOR STANDARDIZATION
COMITÉ EUROPÉEN DE NORMALISATION
EUROPÄISCHES KOMITEE FÜR NORMUNG

Management Centre: rue de Stassart, 36 B-1050 Brussels

Contents		page
Foreword.....		3
Introduction		4
1 Scope		5
2 Normative references		5
3 Bolts		6
4 Nuts		12
5 Designation of the bolt/nut assembly		16
6 Associated washers		16
7 Functional characteristics of the bolt/nut/washer assembly		17
Bibliography		19

iTeh STANDARD PREVIEW
(standards.iteh.ai)

SIST EN 14399-3:2005

<https://standards.iteh.ai/catalog/standards/sist/87b9dee7-ec1c-4d8b-9b5f-788d9b1eaa3b/sist-en-14399-3-2005>

Foreword

This document (EN 14399-3:2005) has been prepared by Technical Committee CEN/TC 185 “Threaded and non-threaded mechanical fasteners and accessories”, the secretariat of which is held by DIN.

This European Standard shall be given the status of a national standard, either by publication of an identical text or by endorsement, at the latest by September 2005, and conflicting national standards shall be withdrawn at the latest by September 2005.

This document includes a Bibliography.

According to the CEN/CENELEC Internal Regulations, the national standards organizations of the following countries are bound to implement this European Standard: Austria, Belgium, Cyprus, Czech Republic, Denmark, Estonia, Finland, France, Germany, Greece, Hungary, Iceland, Ireland, Italy, Latvia, Lithuania, Luxembourg, Malta, Netherlands, Norway, Poland, Portugal, Slovakia, Slovenia, Spain, Sweden, Switzerland and United Kingdom.

iTeh STANDARD PREVIEW (standards.iteh.ai)

[SIST EN 14399-3:2005](https://standards.iteh.ai/catalog/standards/sist/87b9dee7-ec1c-4d8b-9b5f-788d9b1eaa3b/sist-en-14399-3-2005)

<https://standards.iteh.ai/catalog/standards/sist/87b9dee7-ec1c-4d8b-9b5f-788d9b1eaa3b/sist-en-14399-3-2005>

EN 14399-3:2005 (E)

Introduction

This document on structural bolting reflects the situation in Europe where two technical solutions exist to achieve the necessary ductility of bolt/nut/washer assemblies. These solutions utilize different systems (HR and HV) of bolt/nut/washer assemblies, see Table 1. Both systems are well proved and it is up to the experts responsible for structural bolting whether they use the one or the other system.

It is, however, important for the performance of the assembly to avoid mixing up the components of both systems. Therefore, bolts and nuts for both systems are standardized in one single part of this European Standard each and the marking of the components of the same system is uniform.

Table 1 — Systems of bolt/nut/washer assemblies

	Bolt/nut/washer assembly System HR		Bolt/nut/washer assembly System HV
General requirements	EN 14399-1		
Bolt/nut assembly	EN 14399-3		EN 14399-4
Marking	HR		HV
Property classes	8.8/8	10.9/10	10.9/10
Washer(s)	EN 14399-5 or EN 14399-6		EN 14399-5 or EN 14399-6
Marking	H		H
Suitability test for preloading	EN 14399-2		EN 14399-2

Preloaded bolted assemblies are very sensitive to differences in manufacture and lubrication. Therefore it is important that the assembly is supplied by one manufacturer who is always responsible for the function of the assembly.

For the same reason it is important that coating of the assembly is under the control of one manufacturer.

Beside the mechanical properties of the components, the functionality of the assembly requires that the specified pre-load can be achieved if the assembly is tightened with a suitable procedure. For this purpose a test method for the suitability of the components for preloading was created, which will demonstrate whether the function of the assembly is fulfilled.

It should be pointed out that compared to ISO 272 the widths across flats (large series) for M12 and M20 have been changed to 22 mm and 32 mm respectively. These changes are justified by the following reasons.

Under the specific conditions of structural bolting, the compressive stresses under the bolt head or nut for the sizes M12 may become too large with the width across flats of 21 mm, especially if the washer is fitted excentrically to the bolt axis.

For the size M20, the width across flats of 34 mm is very difficult to be produced. The change to 32 mm is primarily motivated by economics but it should also be pointed out that the width across flats of 32 mm is already common practice in Europe.

For the time being, the product standards EN 14399-3 to EN 14399-6 are the only European Standards which have regard to the general requirements of EN 14399-1. However, further product standards on

- fit bolts,
- countersunk head bolts, and
- load indicating washers

for the use in high strength structural bolting for preloading are under preparation.

1 Scope

This document specifies, together with EN 14399-1, the requirements for assemblies of high-strength structural bolts and nuts of system HR suitable for preloaded joints with large widths across flats, thread sizes M12 to M36 and property classes 8.8/8 and 10.9/10.

Bolt and nut assemblies to this document have been designed to allow preloading of at least $0,7 f_{ub} \times A_s$ ¹⁾ according to ENV 1993-1-1 (Eurocode 3) and to obtain ductility predominantly by plastic elongation of the bolt. For this purpose the components have the following characteristics:

- nut height according to style 1 (see EN ISO 4032)
- thread length of the bolt according to ISO 888

Bolt and nut assemblies to this document include washers according to EN 14399-6 or to EN 14399-5 (under the nut only).

NOTE Attention is drawn to the importance of ensuring that the bolts are correctly used if satisfactory results are to be obtained. For recommendations concerning proper application, reference to ENV 1090-1 is made.

The test method for suitability for preloading is specified in EN 14399-2.

2 Normative references

The following referenced documents are indispensable for the application of this document. For dated references, only the edition cited applies. For undated references, the latest edition of the referenced document (including any amendments) applies.

- SIST EN 14399-3:2005
<https://standards.iteh.ai/catalog/standards/sist/87b9dee7-ec1c-4d8b-9b5f-788d9b1eaa3b/sist-en-14399-3-2005>
- EN 493, *Fasteners — Surface discontinuities — Nuts*.
- EN 10045-1, *Metallic materials — Charpy impact test — Part 1: Test method*.
- EN 14399-1, *High-strength structural bolting assemblies for preloading — Part 1: General requirements*.
- EN 14399-2, *High-strength structural bolting assemblies for preloading — Part 2: Suitability test for preloading*.
- EN 14399-5, *High-strength structural bolting assemblies for preloading — Part 5: Plain washers*.
- EN 14399-6, *High-strength structural bolting assemblies for preloading — Part 6: Plain chamfered washers*.
- EN 20898-2, *Mechanical properties of fasteners — Part 2: Nuts with specified proof load values — Coarse thread (ISO 898-2:1992)*.
- EN 26157-1, *Fasteners — Surface discontinuities — Part 1: Bolts, screws and studs for general requirements (ISO 6157-1:1988)*.
- EN ISO 898-1, *Mechanical properties of fasteners made of carbon steel and alloy steel — Part 1: Bolts, screws and studs (ISO 898-1:1999)*.
- EN ISO 3269, *Fasteners — Acceptance inspection (ISO 3269:2000)*.
- EN ISO 4759-1, *Tolerances for fasteners - Part 1: Bolts, screws, studs and nuts - Product grades A, B and C (ISO 4759-1:2000)*.
- EN ISO 10684, *Fasteners - Hot dip galvanized coatings (ISO 10684:2004)*.

¹⁾ f_{ub} is the nominal tensile strength (R_m) and A_s the stress area of the bolt.

EN 14399-3:2005 (E)

ISO 148, *Steel — Charpy impact test (V-notch)*.

ISO 261, *ISO general-purpose metric screw threads — General plan*.

ISO 965-2, *ISO general purpose metric screw threads — Tolerances — Part 2: Limits of sizes for general purpose external and internal screw threads — Medium quality*.

ISO 965-5, *ISO general purpose metric screw threads — Tolerances — Part 5: Limits of sizes for internal screw threads to mate with hot-dip galvanized external screw threads with maximum size of tolerance position h before galvanizing*.

3 Bolts

3.1 Dimensions of bolts

See Figure 1 and Table 2

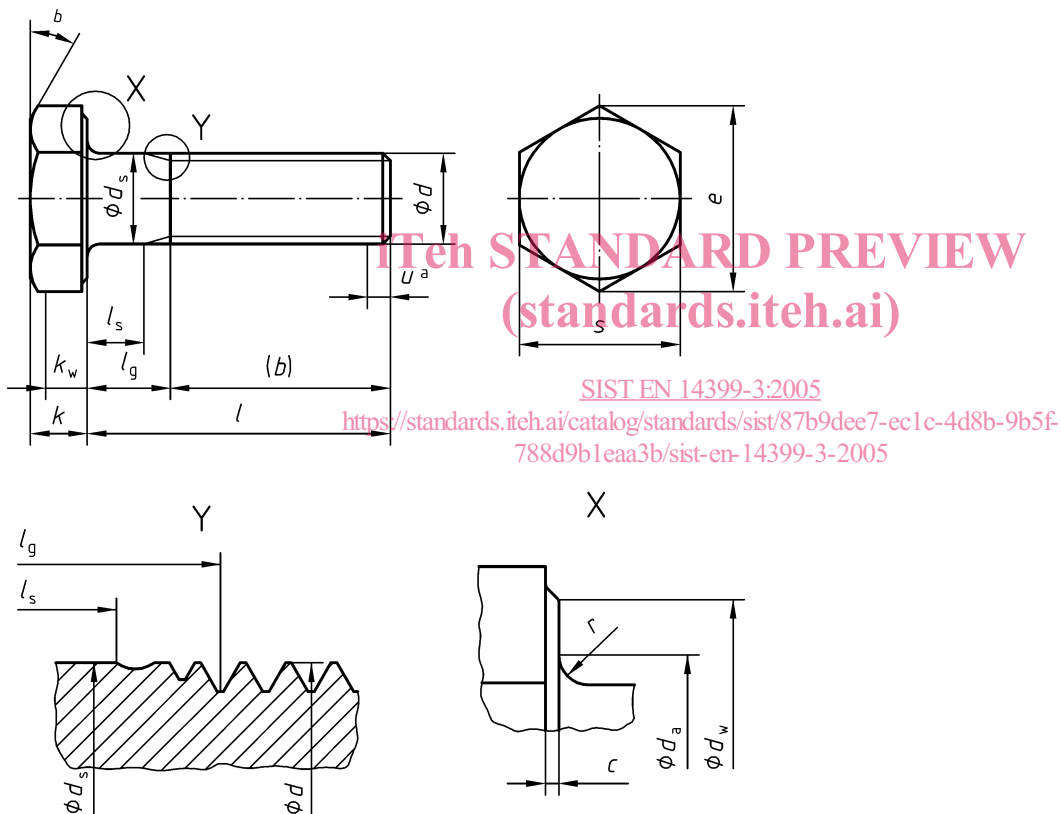

NOTE The difference between l_g and l_s should not be less than $1,5 P$.

Key

- a Incomplete thread $u \leq 2P$
b 15° to 30°

Figure 1 — Dimensions of bolts

Table 2 — Dimensions of bolts ^a

Dimensions in millimetres

Thread <i>d</i>		M12	(M14)^b	M16	(M18)^b	M20
<i>p</i> ^c		1,75	2	2	2,5	2,5
<i>b</i> (ref.)	d	30	34	38	42	46
	e	—	40	44	48	52
	f	—	—	—	—	65
<i>c</i>	max.	0,8	0,8	0,8	0,8	0,8
	min.	0,4	0,4	0,4	0,4	0,4
<i>d_a</i>	max.	15,2	17,2	19,2	21,7	24,4
<i>d_s</i>	max.	12,70	14,70	16,70	18,70	20,84
	min.	11,30	13,3	15,30	17,3	19,16
<i>d_w</i>	max.	g	g	g	g	g
	min.	20,1	22	24,9	27,7	29,5
<i>e</i>	min.	23,91	26,17	29,56	32,95	35,03
<i>k</i>	nom.	7,5	8,8	10	11,5	12,5
	max.	7,95	9,25	10,75	12,4	13,40
	min.	7,05	8,35	9,25	10,6	11,60
<i>k_w</i>	min.	4,9	5,85	6,5	7,42	8,1
<i>r</i>	min.	1,2	1,2	1,2	1,5	1,5
<i>s</i>	max.	22	24	27	30	32
	min.	21,16	23,16	26,16	29,16	31

Table 2 (continued)

Dimensions in millimetres

Thread d			M12		(M14) ^b		M16		(M18) ^b		M20	
l			l_s and l_g ^{h, j}									
nom.	min.	max.	l_s min.	l_g max.	l_s min.	l_g max.	l_s min.	l_g max.	l_s min.	l_g max.	l_s min.	l_g max.
35	33,75	36,25	6	11,25								
40	38,75	41,25	6	11,25			8	14				
45	43,75	46,25	6,25	15			8	14			10	17,5
50	48,75	51,25	11,25	20	7	13	8	14			10	17,5
55	53,5	56,5	16,25	25	11	21	8	14			10	17,5
60	58,5	61,5	21,25	30	16	26	12	22	9	16,5	10	17,5
65	63,5	66,5	26,25	35	21	31	17	27	10,5	23	10	17,5
70	68,5	71,5	31,25	40	26	36	22	32	15,5	28	11,5	24
75	73,5	76,5	36,25	45	31	41	27	37	20,5	33	16,5	29
80	78,5	81,5	41,25	50	36	46	32	42	25,5	38	21,5	34
85	83,25	86,75	46,25	55	41	51	37	47	30,5	43	26,5	39
90	88,25	91,75	51,25	60	46	56	42	52	35,5	48	31,5	44
95	93,25	96,75	56,25	65	51	61	47	57	40,5	53	36,5	49
100	98,25	101,75	61,25	70	56	66	52	62	45,5	58	41,5	54
110	108,25	111,75			66	76	62	72	55,5	68	51,5	64
120	118,25	121,75			76	86	72	82	65,5	78	61,5	74
130	128	132			80	90	76	86	69,5	82	65,5	78
140	138	142			90	100	86	96	79,5	92	75,5	88
150	148	152			100	110	96	106	89,5	102	85,5	98
160	156	164			110	120			99,5	112		
170	166	174										
180	176	184										
190	186	194										
200	196	204										

Table 2 (continued)

Dimensions in millimetres

Thread d		M22	M24	M27	M30	M36
p^c		2,5	3	3	3,5	4
b (ref.)	d	50	54	60	66	78
	e	56	60	66	72	84
	f	69	73	79	85	97
c	max.	0,8	0,8	0,8	0,8	0,8
	min.	0,4	0,4	0,4	0,4	0,4
d_a	max.	26,4	28,4	32,4	35,4	42,4
d_s	max.	22,84	24,84	27,84	30,84	37,00
	min.	21,16	23,16	26,16	29,16	35,00
d_w	max.	g	g	g	g	g
	min.	33,3	38,0	42,8	46,6	55,9
e	min.	39,55	45,20	50,85	55,37	66,44
k	nom.	14	15	17	18,7	22,5
	max.	14,90	15,90	17,90	19,75	23,55
	min.	13,10	14,10	16,10	17,65	21,45
k_w	min.	9,2	9,9	11,3	12,4	15,0
r	min.	1,5	1,5	2,0	2,0	2,0
s	max.	36	41	46	50	60
	min.	35	40	45	49	58,8