



Designation: F 2011 – 02

Standard Specification for Safety and Performance of Fun-Karts¹

This standard is issued under the fixed designation F 2011; the number immediately following the designation indicates the year of original adoption or, in the case of revision, the year of last revision. A number in parentheses indicates the year of last approval. A superscript epsilon (ϵ) indicates an editorial change since the last revision or reapproval.

1. Scope

1.1 This specification relates to the safety performance specifications for commercially manufactured fun-karts intended for private use, on suitable off-road terrain, by consumers.

1.2 This specification is intended to reduce hazards, other than those inherent in the sport of fun-karting, to the users of fun-karts during normal intended use by specifying performance standards of manufacturing.

1.3 This specification applies to fun-karts for private use and does not apply to concession, race, home-made, consumer-modified fun-karts, fun-karts that are pedal-powered, unpowered fun-karts, or fun-karts, which are used for commercial purposes.

1.4 This specification recognizes that there are operational hazards relating to fun-karts, which operators and passengers are deemed to have accepted by their use and operation of the fun-kart including, but not limited to, falling out, running into, through, under or over objects, upsetting the fun-kart, general operator recklessness, pinches, scratches, or bruises, or a combination thereof.

1.5 This specification does not cover labeling, maintenance, or use. For use and maintenance, see Safety Guide F 1928.

2. Referenced Documents

2.1 ASTM Standards:

F 1928 Safety Guide for Consumer Recreational Use of Fun-Karts²

2.2 CPSA Document:³

CFR 1303

2.3 FMVSS Standards:³

FMVSS 571.209

2.4 SAE Standard:⁴

SAE J 386

2.5 ANSI Standard:⁵

ANSI/OPEI B71.1, 1998

3. Terminology

3.1 Definitions of Terms Specific to This Standard:

3.1.1 *axle guard, n*—a device that covers the drive axle on fun-karts so that the possibility of injury resulting from hand, hair, loose clothing, or body parts contacting the axle is reduced.

3.1.2 *brush bars, n*—any device supplied by the manufacturer intended to deflect loose vegetation from the path of the fun-kart operator, and passenger in two-seat fun-karts.

3.1.3 *control pedal pivot, n*—the center point about which the control pedal rotates. Excluded from this definition are any control device(s) attached to the pedal itself.

3.1.4 *deck plates, n*—a form of guarding through the use of relatively flat barriers to cover rotating components.

3.1.5 *engine stop switch, n*—a toggle switch, or other two-position positively engaging switch, which when activated causes the engine to stop or not operate, or both.

3.1.6 *engine throttle system, n*—the throttle mechanism attached to the engine, as provided by the engine manufacturer.

3.1.7 *fun-kart, n*—a motorized vehicle with four wheels, excluding vehicles which the operator, and passenger, if any, sit astride, sold commercially as consumer goods and intended for private personal recreational use by consumers for off-road use on suitable terrain, as recommended by the manufacturer, at maximum speeds over 12 mph (19.3 km/h) but not exceeding 40 mph (64.4 km/h).

3.1.8 *fun-kart accelerator system, n*—the mechanical system, that is, accelerator pedal, actuation rod or linkage, which is separate from the engine throttle system, and which is used to control the throttle position of the fun-kart engine.

3.1.9 *locking fastener, n*—includes prevailing torque lock-nuts, cotter pins, serrated surface lock nuts, pal nuts, safety wire and similar hardware intended to prevent unintended loosening when properly used.

¹ This standard is under the jurisdiction of ASTM Committee F15 on Consumer Products and is the direct responsibility of Subcommittee F15.41 on Fun-Karts.

Current edition approved Nov. 10, 2002. Published January 2003. Originally approved in 2000. Last previous edition approved in 2000 as F 2011 – 00.

² *Annual Book of ASTM Standards*, Vol 15.07.

³ *Code of Federal Regulations*, available from U.S. Government Printing Office, Washington, DC 20402.

⁴ Available from SAE International, 400 Commonwealth Drive, Warrendale, PA 15096-0001.

⁵ Available from American National Standards Institute (ANSI), 25 W. 43rd St., 4th Floor, New York, NY 10036.

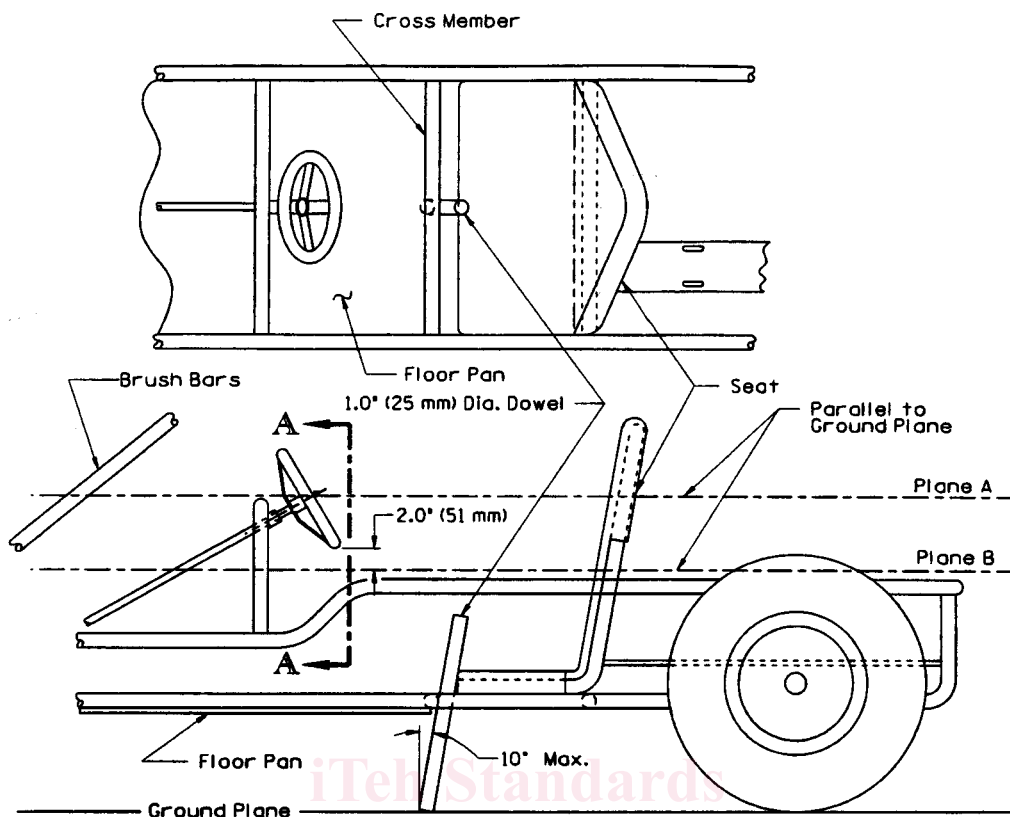

FIG. 1 Diagram of Fun-Kart Frame

3.1.10 *normally-seated position, n*—see Safety Guide F 1928 for specifics.

3.1.11 *over center, n*—a condition where the steering linkages bind when the pitman arm is allowed to travel beyond its normal range of motion.

3.1.12 *pan, n*—the barrier surface extending forward from in front of the seat to where the operator/passengers rest their feet.

3.1.13 *pitman arm, n*—the link between the steering column and the tie rod(s).

3.1.14 *throttle stop, n*—a device used to limit the travel of the accelerator system.

3.1.15 *two-seat fun-kart, n*—a fun-kart with designed seating to accommodate one operator and one passenger.

4. Fun-Kart Frame

4.1 Each fun-kart shall be equipped with a floor pan with the following characteristics:

4.1.1 The back-edge of the pan shall extend to a point that a 1 in. (25 mm) dowel rod between the back of the pan and the front of the seat bottom or its attachment point, with the seat in a full backward position, shall be a maximum of 90° off of vertical (see Fig. 1).

4.1.2 The front-edge of the pan shall extend, at a minimum, to a point in front of the operator’s heel position, with the operator normally seated and able to operate the foot pedal controls.

4.1.3 The pan shall be solid and uninterrupted (comprised of one or more pieces).

4.1.4 The width of the pan (see Fig. 2) shall include any frame rails to which it is mounted, provided there is no vertical gap between the edge of the pan and the frame rails.

4.1.5 The seat shall be centered laterally over the pan.

4.1.6 The pan on single-seat fun-karts must be at least 14 in. (356 mm) wide at its rear-edge.

4.1.7 The pan on two-seat fun-karts must be at least 20 in. (508 mm) wide at its rear-edge.

4.2 Seating:

4.2.1 Fun-karts shall be equipped with a rigid device, along the outer edges of the fun-kart, either integral with the seat itself or located in the frame of the fun-kart, to help maintain the operator’s/passenger’s position in the seat about a lateral axis of the fun-kart. This device shall extend, at a minimum, the full depth of the base of the seat. On fun-karts equipped with adjustable seats, the device shall extend throughout all seat positions or be mounted to the seat itself.

4.2.2 The seat shall not extend more than 3-½ in. (90 mm) per side over the pan.

4.2.3 On two-seat fun-karts, the steering wheel center shall be located within 3 in. (76 mm) of the center line of the seating position of the fun-kart’s operator, when seated in a normal operating position.

4.3 Steering Support Columns:

4.3.1 On fun-karts equipped with steering column support of less than 4 in. (102 mm) of width, measured at a point 2 in. (51 mm) below lower edge of the steering wheel, the steering wheel support shall be padded.

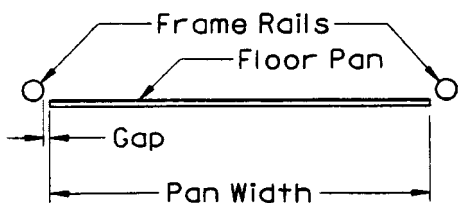
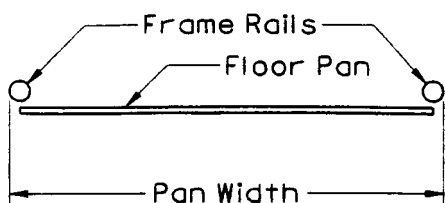

FIG. 2 Floor Pan Width Measurement

4.3.2 No support column shall have a stop switch or other device projecting from the surface facing the operator, unless it is at or above a horizontal parallel plane measured at a point 2 in. (51 mm) below the lower edge of the steering wheel.

4.4 Sharp edge test (Reserved).

4.5 Fun-kart steering mechanisms shall be designed, such that the mechanism cannot go into an “over center” condition.

4.6 The rear of fun-karts shall be designed to prevent any contact with the fuel tank, carburetor, or battery should the kart be backed straight into a vertical wall at a speed of 2 mph (3.2 km/h).

4.7 A front bumper assembly, or the fun-kart frame itself, shall extend in front of the steering tie rods.

5. Fun-Kart Controls

5.1 Fun-karts, or their control pedals, or both, when properly used, shall be designed to help retain the operator’s feet inside the kart.

5.2 Each control pedal pivot shall be of such a design that over-tightening the fastening mechanism will not result in binding of the pivot.

5.3 In two-seat fun-karts, the kart shall be equipped with devices that are designed, when properly used, to help keep the passenger’s feet:

5.3.1 Clear of the fun-kart’s steering mechanism and control pedals, and

5.3.2 Inside the fun-kart.

5.4 *Control Pedal Positions:*

5.4.1 On fun-karts equipped with pedal controls, the controls shall be located as follows:

5.4.1.1 The accelerator pedal shall be to the right of the operator’s seated position and operated by the right foot.

5.4.1.2 The brake pedal shall be to the left of the operator’s seated position and operated by the left foot.

5.4.1.3 Any other configuration of accelerator and brake location shall be labeled clearly and plainly.

5.4.2 With the seat in its full-forward position, there shall be no less than 28 in. (711 mm) between the forward position of the seat back to the pedals at their fully engaged position.

5.4.3 In two-seat fun-karts, any control pedal located in the middle of the kart shall be located within 3 in. (76 mm) of the center line of the kart.

5.5 There shall be a remote engine stop switch, with the operating characteristics specified in 3.1.5, located on the steering wheel or steering column, as directed in 4.3.2, and easily accessible by the operator.

5.6 *Fun-Kart Accelerator System:*

5.6.1 There shall be a return spring attached to the accelerator’s actuating mechanism, that is, accelerator pedal, actuation rod or linkage.

5.6.2 There shall be a stop to limit the travel of the accelerator actuation mechanism. This stop must be external of the engine and its throttle mechanism.

5.7 The attachment point of the steering tie rod to the pitman arm shall be no lower than at the center line of the front axle assembly, unless appropriately guarded to help prevent damage to the steering mechanism from contact with the ground.

6. Tire Capacity

6.1 In specifying tires for use on fun-karts, manufacturers shall specify a tire that has a load bearing capacity, at a minimum, of the maximum gross vehicle weight of the fun-kart divided by four.

7. Paint

7.1 Paint on fun-karts shall comply with the lead content provisions of 16 CFR 1303.

8. Electrical

8.1 On fun-karts equipped with batteries, or electrical systems, or both:

8.1.1 The battery compartment shall be marked permanently to show the correct battery orientation, polarity, voltage, and size.

8.1.2 All vented batteries shall have a vent tube, which is pointed downwards and which extends below the bottom of the battery. The battery end of the vent tube shall be attached securely to the battery. The drain end of the vent tube shall be secured within 1 in. (25 mm) of the end of the tube.

8.1.3 All positively-charged electrical connections shall have insulated coverings.

9. Fun-Kart Engines

9.1 There shall be a throttle return spring as part of the engine throttle system.

9.2 Fun-kart engine exhaust systems shall be equipped with a heat guard.

9.3 There shall be an engine mounted stop switch with the operating characteristics specified in 3.1.5.

9.4 Fun-kart engine rewind starter assemblies shall be guarded.

9.5 Engine standards are currently under development. This area is reserved for standards, test methods, or prints, or a combination thereof, to be incorporated at a later date. The methods, or prints, or both will be a part of this specification.

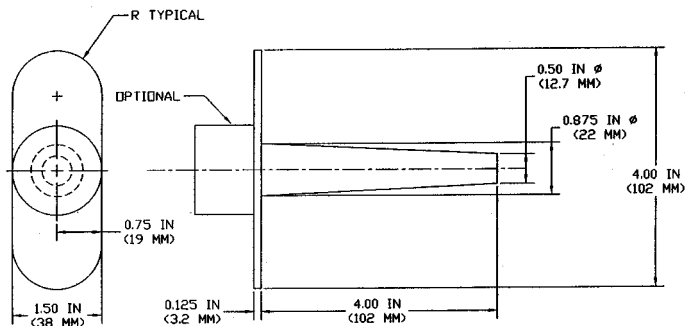

FIG. 3 Finger Probe

10. Shields and Guards

10.1 All power-driven shafts, brakes, chains, belts, gears, sprockets, and pulleys (excluding tires, wheels, outer ends of the axles and cooling openings on the engine) on fun-karts manufactured after July 1, 2003 shall be guarded as follows:

10.1.1 Guards for the rotating components outlined in 10.1 shall be permitted to have multiple holes each no larger than 0.05 in.² (32 mm²) area.

10.1.2 Guard all live axles and jack shafts, including the ends of any jack shaft.

10.1.2.1 If floating axle guards are used, they will operate independently of the axle and the axle-mounted components. Any end clearance as manufactured shall not exceed 1/8 in. (3.2 mm) of total end play.

10.1.3 All guards and shields for pulleys and sprockets shall be secured permanently or attached in order to prevent their removal from the kart without tools. The fasteners for those guards and shields shall be reusable.

10.1.4 Nip and pinch point hazards related to power driven gears, friction drives and brake components, belts, chains, and idlers as well as hazards related to the faces of pulleys, discs, drums, sprockets, and gears shall be guarded by location or otherwise guarded to prevent inadvertent contact by the operator, and passenger on two seat karts, during normal seating, starting of the engine, and operation of the kart.

A component will be considered sufficiently guarded if it cannot be contacted with probe as shown in Fig. 3 when tested in accordance with 10.1.4.1.

These guarding requirements do not pertain to contact during maintenance activities.

These guarding requirements are in addition to the hair entanglement test set out in 10.1.5.

10.1.4.1 (**Warning**—The following procedures should not be conducted with the engine running.) Insert the probe (see Fig. 3) into all openings to its maximum depth (4 in. (102 mm)) or until a force of 1 lb (4.5 n) is attained. As the probe is inserted, rotate and position it in all possible angles within the opening, attempting to contact the part or parts under test. The finger probe shall not be inserted beyond the length of the probe (4 in. (102 mm)). Probe cannot contact any rotating component.

10.1.4.2 The hazards shall be considered “guarded by location” if one of the following applies:

(1) The hazard is covered by other parts or components of the kart, or because of its location, cannot be contacted with the

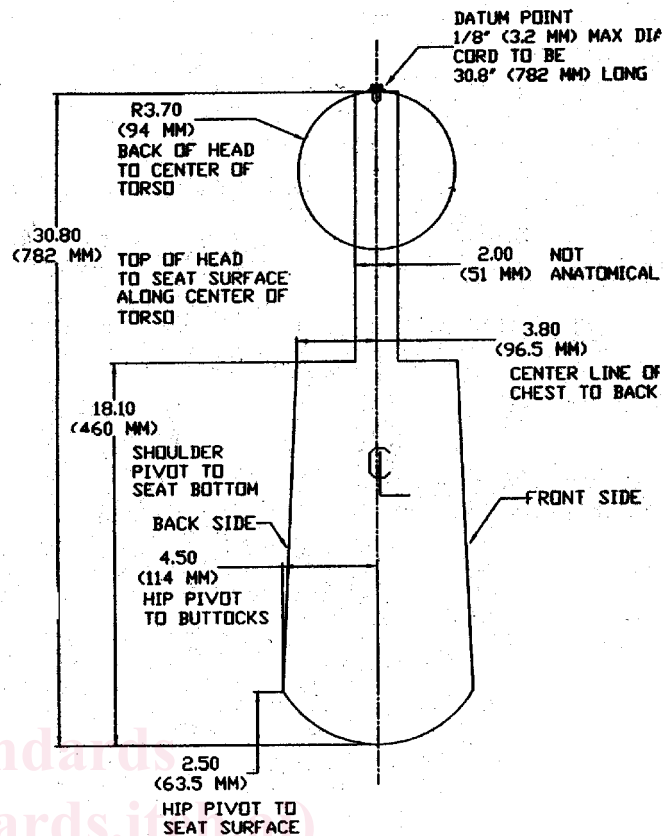

FIG. 4 Test Torso Female Model 2.5 %

finger probe shown in Fig. 3 (see ANSI/OPEI B71.1, 1998) while maneuvering the probe in any manner; or

(2) The hazard is under and within the perimeter of the chassis components, such that the hazard cannot be reached with the finger probe shown in Fig. 3 (see ANSI/OPEI B71.1, 1998) while maneuvering the probe as follows:

(a) From above the chassis, downward through openings in or between the components; and

(b) Underneath the chassis components, allowing only horizontal or downward probe movement, or both.

(3) The hazard does not rotate when the kart is stationary and the operator, and passenger in a two seat kart, cannot reach the hazard while in a Normally Seated Position (see Note 1 and Note 2).

NOTE 1—The entanglement test set out in 10.1.5 must also be complied with.

NOTE 2—Normally Seated Position is defined as the operator, and any passenger in a two seat kart, with their buttocks on the horizontal seating surface and with the small of their back against the seat back with restraint belts properly fastened and adjusted.

10.1.5 The hair entanglement test for the guarding specified in this section is as follows (**Warning**—The following procedures should not be conducted with the engine running.):

10.1.5.1 Select one of the torso and head models as per Fig. 4 and Fig. 5.

10.1.5.2 Locate torso and head model in kart seat, reference Fig. 6 and Fig. 7, as appropriate.

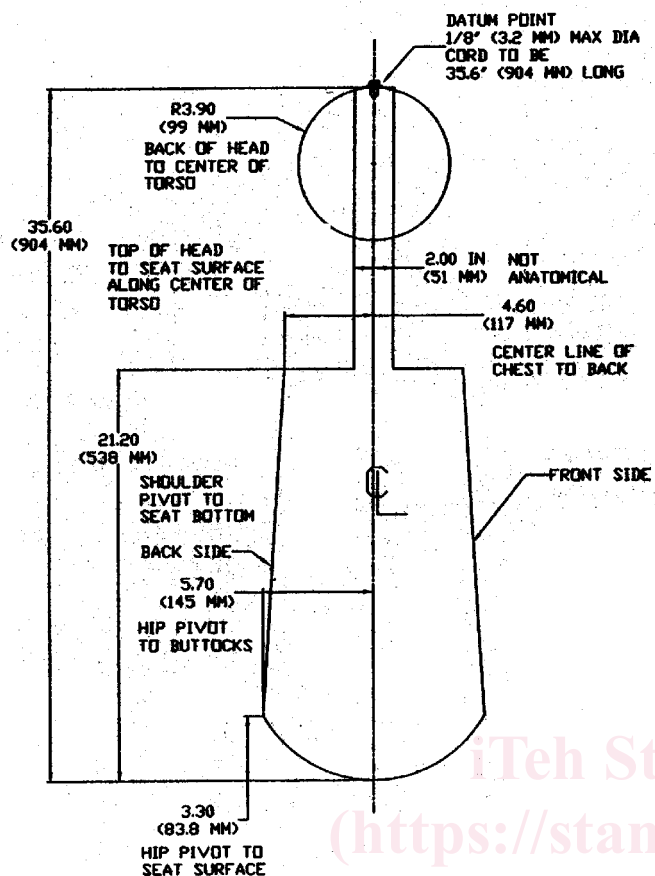

FIG. 5 Test Torso Female Model 97.5 %

10.1.5.3 With the test kart in its original configuration (including all guarding properly installed), no portion of the cord may contact rotating axle, jackshafts, chains, sprockets, or rotating brake components no matter how the cord is routed (see Note 3).

NOTE 3—In the test, do not consider those items excluded in 10.1 of this standard.

(1) Conduct test though entire range specified, 20° of lateral lean either side of center, as set out in Fig. 8 and Fig. 9, as appropriate.

- (2) Repeat test for second seat on two seat karts.
- (3) Repeat test for second torso and head model

11. Brush Bars

11.1 On all fun-karts with a design speed in excess of 15 mph (24.1 km/h), manufactured after July 1, 1999, brush bars shall be provided and meet the following:

11.1.1 Brush bars shall be designed to help provide protection to the occupant(s) of fun-karts, when seated properly in the designated seat(s), from loose vegetation that might be encountered while operating the fun-kart.

11.1.2 Brush bars shall have a minimum width, measured at the center of the steering wheel (see View A-A in Fig. 3) of:

11.1.2.1 10 in. (254 mm) on single-seat fun-karts.

11.1.2.2 18 in. (457 mm) on double-seat fun-karts.

11.1.2.3 This measurement is to be taken across the outside edges of the brush-bar tubing.

11.1.3 The outer edges of the brush-bar assembly shall be symmetrical to the centerline of the fun kart.

11.1.4 Other dimensions, design specifications, and test methods currently are under development. This area is reserved space for the methods, or prints, or both, to be incorporated at a later date. The methods, or prints, or both, will be a part of this specification.

12. Seat Belts

12.1 All fun-karts with a design speed in excess of 15 mph (24.1 km/h), manufactured after July 1, 1999, shall be equipped with Type 2 (see FMVSS 571.209) seat belts.

12.1.1 Seat belts, their hardware, and attachment points shall be in accordance with SAE J386.

12.1.2 Fun-karts with seat belts shall be equipped with a retracting device or other means to help prevent any unfastened belt from becoming entangled in rotating components.

12.1.3 Two-seat fun-karts with seat belts shall have separate seat belts for the operator and passenger.

13. Fasteners

13.1 Fun-kart manufacturers shall provide a schedule for those fasteners originally provided by the fun-kart OEM. Fasteners integral to component parts need not be included in such a schedule.

13.2 Fasteners used for wheel hubs, brake pivots, accelerator pivots, steering linkage pivots, axle attachments and brush-bar attachments shall be locking fasteners.

14. Plastics

14.1 Fun-kart components made of plastic shall be fire retardant.

14.2 Fun-kart components made of plastic shall have a UV inhibitor.

15. Keywords

15.1 fun-kart; go-kart; kart

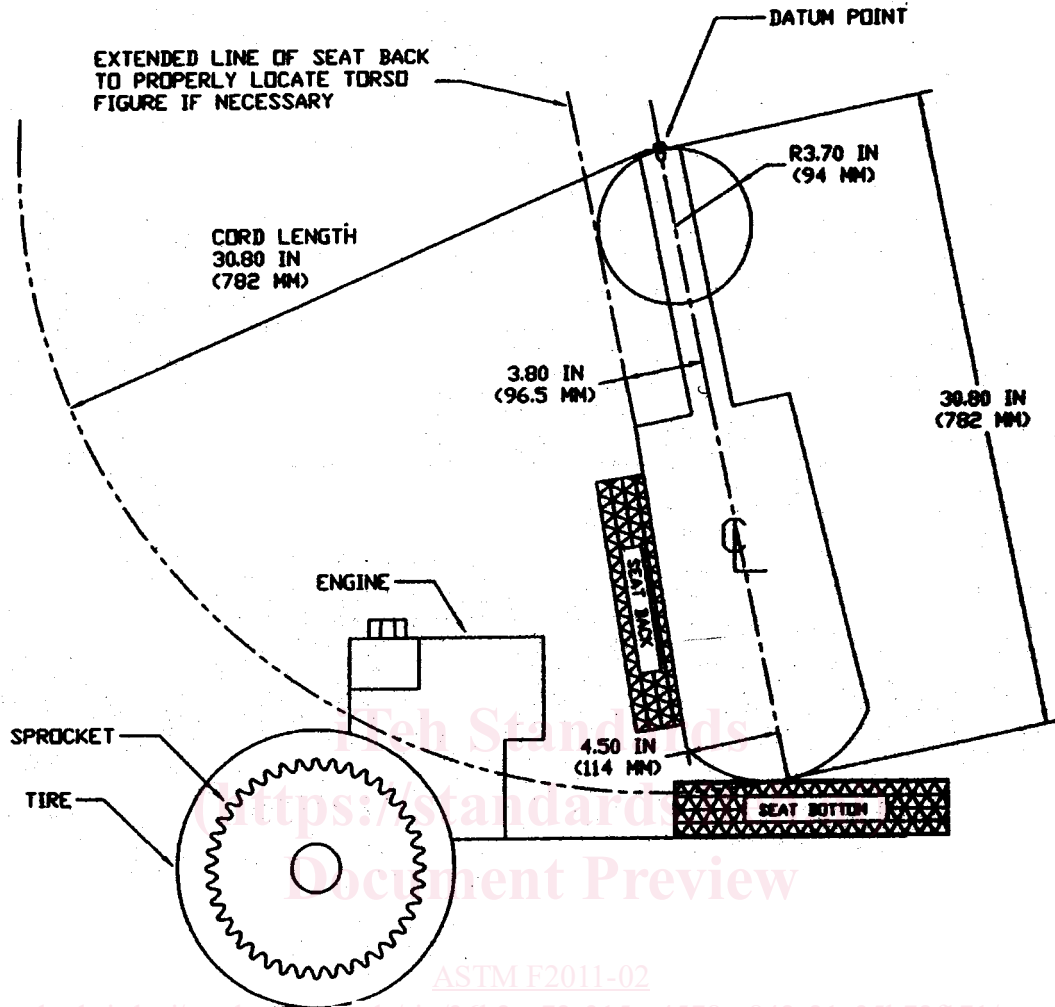

NOTE 1—Position of drive components may vary and are shown for illustration purposes only.

FIG. 6 Side View of Guarding Test - Female 2.5 %