

INTERNATIONAL
STANDARD

ISO
12128

First edition
1995-04-01

**Plain bearings — Lubrication holes,
grooves and pockets — Dimensions, types,
designation and their application to
bearing bushes**
(standards.iteh.ai)

*Paliers lisses — Trous, rainures et poches de graissage — Dimensions,
types, désignation et leurs applications dans les bagues*
<https://standards.iteh.ai/catalog/standards/sist/e06f3d40-c0d8-4974-98ea-22bdb02f39d6/iso-12128-1995>

INTERNATIONAL

ISO



Reference number
ISO 12128:1995(E)

Foreword

ISO (the International Organization for Standardization) is a worldwide federation of national standards bodies (ISO member bodies). The work of preparing International Standards is normally carried out through ISO technical committees. Each member body interested in a subject for which a technical committee has been established has the right to be represented on that committee. International organizations, governmental and non-governmental, in liaison with ISO, also take part in the work. ISO collaborates closely with the International Electrotechnical Commission (IEC) on all matters of electrotechnical standardization.

Draft International Standards adopted by the technical committees are circulated to the member bodies for voting. Publication as an International Standard requires approval by at least 75 % of the member bodies casting a vote.

International Standard ISO 12128 was prepared by Technical Committee ISO/TC 123, *Plain bearings*, Subcommittee SC 3, *Dimensions, tolerances and construction details*.

<https://standards.iteh.ai/catalog/standards/sist/e06f3d40-c0d8-4974-98ea-22bdb02f39d6/iso-12128-1995>

© ISO 1995

All rights reserved. Unless otherwise specified, no part of this publication may be reproduced or utilized in any form or by any means, electronic or mechanical, including photocopying and microfilm, without permission in writing from the publisher.

International Organization for Standardization
Case Postale 56 • CH-1211 Genève 20 • Switzerland

Printed in Switzerland

Plain bearings — Lubrication holes, grooves and pockets — Dimensions, types, designation and their application to bearing bushes

1 Scope

This International Standard specifies dimensions for lubrication holes, grooves and pockets for bearing bushes. These dimensions can be entered, for example on drawings, using the designation examples. Their use depends in particular on the specific operating conditions.

In addition, it enables the user to assign the different types of lubricant feed and distribution to plain bearing bushes made of copper alloys, thermosetting plastics, thermoplastics or of artificial carbon.

NOTE 1 Different types of lubricant feed and distribution for plain bearing bushes made of sintered metals have not been specified due to the fact that these bushes are soaked with lubricant. Plain bearing bushes made of artificial carbon are not lubricated with oil or grease.

ISO 12128:1995

2 Normative references

<https://standards.iteh.ai/catalog/standards/sist/e06f3d40-c0d8-4974-98ea-22bdb02f39d6/iso-12128-1995>

The following standards contain provisions which, through reference in this text, constitute provisions of this International Standard. At the time of publication, the editions indicated were valid. All standards are subject to revision, and parties to agreements based on this International Standard are encouraged to investigate the possibility of applying the most recent editions of the standards indicated below. Members of IEC and ISO maintain registers of currently valid International Standards.

ISO 2768-1:1989, *General tolerances — Part 1: Tolerances for linear and angular dimensions without individual tolerance indications*.

ISO 4379:1993, *Plain bearings — Copper alloy bushes*.

3 Dimensions, types and designation

The dimensions of the lubrication holes, grooves and pockets are related to the bearing wall thickness s . The given diameter d_1 shall only serve as an auxiliary dimension.

All dimensions are given in millimetres.

3.1 Lubrication holes

3.1.1 Dimensions and types

See figure 1 and table 1.

Lubrication holes may be provided in conjunction with lubrication grooves and pockets, or, if the requirement to be met by a lubrication point is less stringent, even without these.

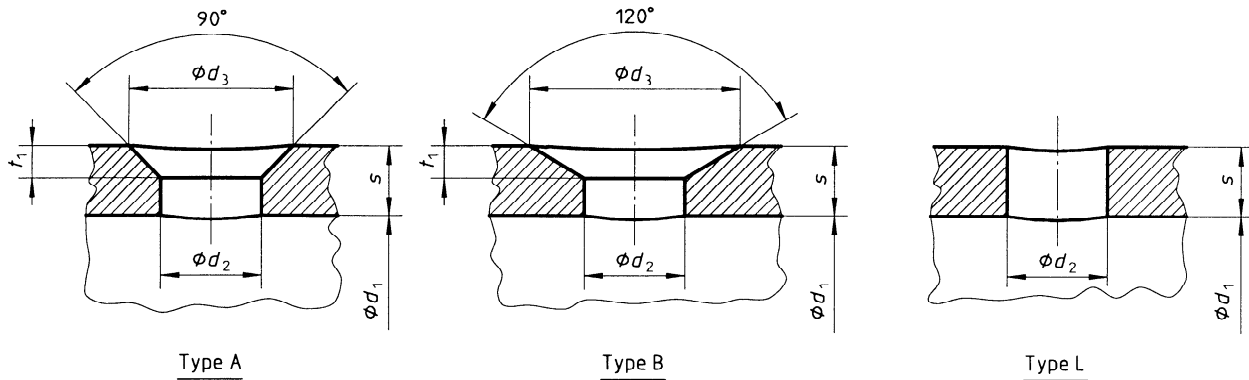

Figure 1 — Lubrication holes
(standards.iteh.ai)

ISO 12128:1995
<https://standards.iteh.ai/catalog/standards/sist/e06f3d40-c0d8-4974-98ea-22bdb02f39d6/iso-12128-1995>

Table 1 — Dimensions of the lubrication holes

$d_2 \approx$		2,5	3	4	5	6	8	10	12
$t_1 \approx$		1	1,5	2	2,5	3	4	5	6
$d_3 \approx$	Type A	4,5	6	8	10	12	16	20	24
	Type B	6	8,2	10,8	13,6	16,2	21,8	27,2	32,6
s	over	—	2	2,5	3	4	5	7,5	10
	up to and incl.	2	2,5	3	4	5	7,5	10	—
d_1	nominal	$d_1 \leq 30$		$30 < d_1 \leq 100$			$d_1 > 100$		

3.1.2 Designation

Designation of a lubrication hole, for example of type A with bore diameter $d_2 = 3$ mm:

Lubrication hole ISO 12128 - A3

3.2 Lubrication grooves

3.2.1 Dimensions and types

See figures 2 and 3 and tables 2 and 3.

Lubrication grooves are mainly provided on plain bearings. Types C, D and E are also used in conjunction with type H (circumferential groove), predominantly on plain bearings made of non-ferrous metal, steel, cast iron or plastics, types F and G predominantly on plain bearings made from artificial carbon.

Type J is a narrow blended groove principally for use with grease lubrication. In order to facilitate machining and avoid burrs, all sharp corners may have a small break edge or radius.

NOTE 2 In order to facilitate manufacture, the dimension of the bearing thickness remaining at the base of the groove may be specified on the drawing as the control dimension.

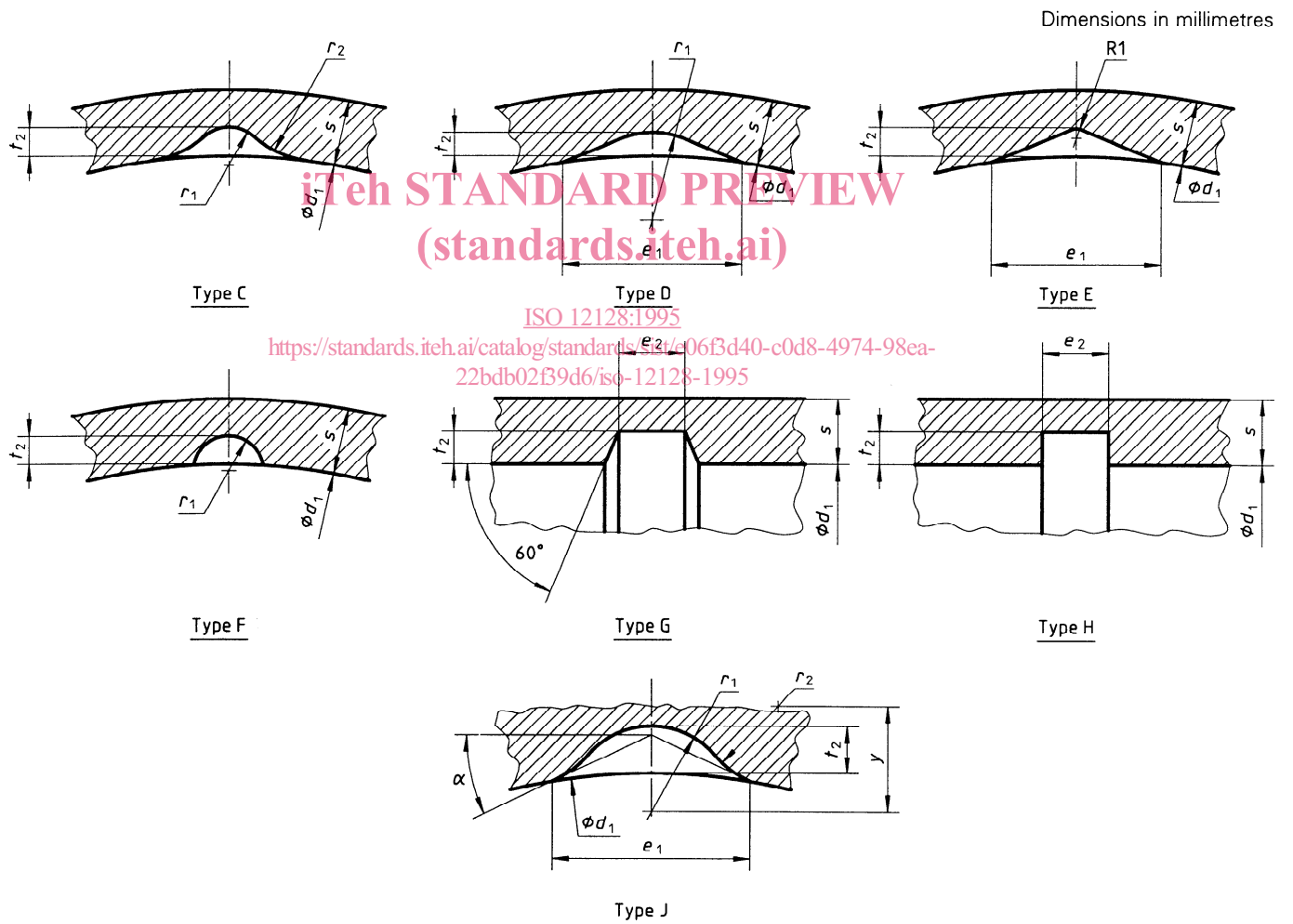

Figure 2 — Lubrication grooves

Table 2 — Dimensions of lubrication grooves

t_2 +0,2 0	e_1 ≈		e_2 ≈		r_1 ≈				r_2 ≈		y ≈	α° ≈	s		d_1	
	Type	Type	Type	Type	Type	Type	Type	Type	Type	Type	Type	Type	over	up to and incl.	Type	Type
C to J	D, E	J	G	H	C	D	F	J	C	J	J	J			C to H	J
0,4	3	3	1,2	3	1,5	1,5	1	1	1,5	1	1,5	28	—	1	$d_1 \leq 30$	16
0,6	4	4	1,6	3	1,5	1,5	1	1,5	2	1,5	2,1	25	1	1,5		20
0,8	5	5	1,8	3	1,5	2,5	1	1,5	3	1,5	2,2	25	1,5	2		30
1	8	6	2	4	2	4	1,5	2	4,5	2	2,8	22	2	2,5		40
1,2	10,5	6	2,5	5	2,5	6	2	2	6	2	2,6	22	2,5	3	$d_1 \leq 100$	40
1,6	14	7	3,5	6	3	8	3	2,5	9	2,5	3	20	3	4		50
2	19	8	4,5	8	4	12	4	2,5	12	2,5	2,6	20	4	5		60
2,5	28	8	7,5	10	5	20	5	3	15	3	2,8	20	5	7,5	$d_1 > 100$	70
3,2	38	—	11	12	7	28	7	—	21	—	—	—	7,5	10		—
4	49	—	14	15	9	35	9	—	27	—	—	—	10	—		—

(standards.iteh.ai)

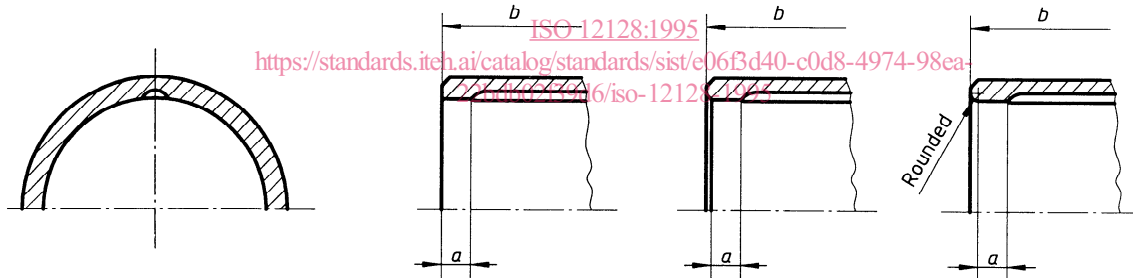

Figure 3 — Lubrication grooves with closed ends

Table 3 — Dimensions for distance a

b nom.	$15 \leq b \leq 30$	$30 < b \leq 60$	$60 < b \leq 100$	$b > 100$
a	3	4	6	10

3.2.2 Designation

Designation of a lubrication groove, for example of type D with groove depth $t_2 = 0,8$ mm:

Lubrication groove ISO 12128 - D0,8

3.3 Lubrication pockets

3.3.1 Dimensions and types

See figure 4 and table 4.

Lubrication pockets shall in general be provided in cases where larger lubrication spaces are required. Type K shall predominantly be used for plain slideways with a to-and-fro movement in a straight line.

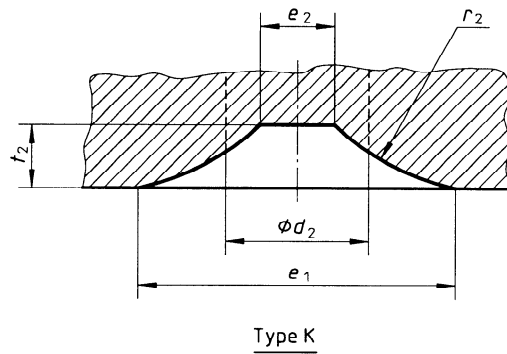

Figure 4 — Lubrication pocket

iTeh STANDARD PREVIEW

(standards.iteh.ai)

Table 4 — Dimensions of the lubrication pockets

t_2	d_2	e_1	e_2	r_2
1,6	6	8	1,8	6,5
2,5	8	15	2,8	14
4	10	24	4,5	20
6	12	35	6,3	30

3.3.2 Designation

Designation of a lubrication pocket type K, for example with pocket depth $t_2 = 2,5$ mm:

Lubrication pocket ISO 12128 - K2,5

3.4 Design

Permissible deviations without tolerance indications shall be in accordance with tolerance class "m" specified in ISO 2768-1. The edges shall be chamfered to 0,5 max. or rounded. Sharp-edged transitions to the sliding surface shall be avoided.

Lubrication holes, grooves and pockets should not be arranged in the stressed zone of the plain bearing. With the exception of plain bearings made from artificial carbon, lubrication grooves and pockets shall in general not be made over the whole length of the bearing. The shape of the groove or pocket runout shall be left to the manufacturer's discretion.

NOTE 3 When producing lubrication grooves and pockets in plain bearings from tough and hard materials, chatter marks may occur on the bottom of the groove, which do not impair the operation of the plain bearing. Lubrication holes, grooves and pockets are not provided on plain bearings made from sintered metal, since these are soaked with lubricant.

4 Lubrication holes, grooves and pockets on bearing bushes (see table 5)

The dimensions and types of the lubrication holes, grooves and pockets on bearing bushes in accordance with this International Standard are given in 3.1 to 3.3.

Examples for the designation of bearing bushes without lubrication holes, grooves and pockets are to be taken from the relevant standards on dimensions.

The symbol x represents in the ISO designation the required distance from the insert side, unless $x = b/2$, and the symbol h represents the required dimension for the groove pitch, which is from $0,1b$ up to $1b$.

If two lubrication holes and grooves are provided, they shall be located at 180° to each other, three holes and grooves at 120° and four at 90° to each other.

Only one type and one bush form are illustrated and designated, each with freely chosen values for the dimensions x and h .

5 Examples of the designation of bushes with lubrication holes and/or grooves

Designation of a bush C $20 \times 24 \times 20$ Y made of CuSn8P in accordance with ISO 4379, with two lubrication holes of type L (2L) corresponding to bush type A of this International Standard, off-centre, with distance $x = 6$ mm:

Bush ISO 4379 - C $20 \times 24 \times 20$ Y - A2L6 - CuSn8P

Designation of the same bush but with two longitudinal grooves of type D (2D) corresponding to bush type C of this International Standard:

Bush ISO 4379 - C $20 \times 24 \times 20$ Y - A2L6C2D - CuSn8P

Designation of a bush C $20 \times 24 \times 20$ Y made of CuSn8P in accordance with ISO 4379, with three longitudinal grooves of type D (3D) corresponding to bush type C of this International Standard, in conjunction with one circumferential groove of type H (1H) corresponding to bush of type E of this International Standard, off-centre, with distance $x = 6$ mm:

Bush ISO 4379 - C $20 \times 24 \times 20$ Y - C3DE1H6 - CuSn8P

Table 5 — Types of bearing bushes

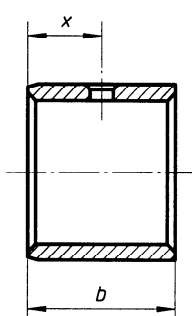
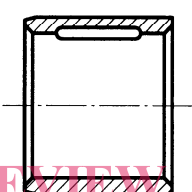
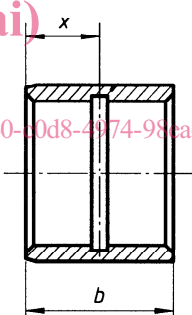
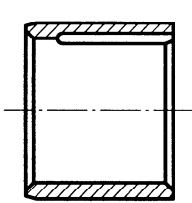
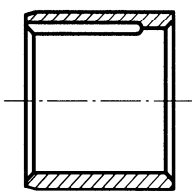
Bush type	Lubrication holes, grooves and pockets		Bearing bush material
	Type in accordance with clause 3	Type and application	
A	A B L J	Lubrication hole, in-centre or off-centre 	Copper alloys Thermosetting plastics Thermoplastics
C	C D E J	Longitudinal groove closed at both ends 	Copper alloys Thermosetting plastics Thermoplastics
E	G H J	Circumferential groove in-centre or off-centre 	Copper alloys Thermosetting plastics Thermoplastics Artificial carbon
G	C D E J	Longitudinal groove open at the end opposite the insert side 	Copper alloys Thermosetting plastics Thermoplastics
H	C D E J	Longitudinal groove open at the end towards the insert side 	Copper alloys Thermosetting plastics Thermoplastics