



SLOVENSKI STANDARD SIST EN 2591-613:2004

01-maj-2004

Aerospace series - Elements of electrical and optical connection - Test methods - Part 613: Optical elements - Impact test

Aerospace series - Elements of electrical and optical connection - Test methods - Part 613: Optical elements - Impact test

Luft- und Raumfahrt - Elektrische und optische Verbindungselemente - Prüfverfahren - Teil 613: Optische Elemente - Fallprüfung

Série aérospatiale - Organes de connexion électrique et optique - Méthodes d'essais - Partie 613: Organes optiques - Résistance à l'impact

<https://standards.iteh.ai/catalog/standards/sist/d2dbab82-668f-4312-9eb2-7da9d7af4655/sist-en-2591-613-2004>

Ta slovenski standard je istoveten z: EN 2591-613:2002

ICS:

49.060 Štejni in optični oprema za letalstvo in vesolje
Aerospace electric equipment and systems

SIST EN 2591-613:2004

en

iTeh STANDARD PREVIEW
(standards.iteh.ai)

SIST EN 2591-613:2004

<https://standards.iteh.ai/catalog/standards/sist/d2dbab82-668f-4312-9eb2-7da9d7af4655/sist-en-2591-613-2004>

EUROPEAN STANDARD
NORME EUROPÉENNE
EUROPÄISCHE NORM

EN 2591-613

June 2002

ICS 49.060

English version

**Aerospace series - Elements of electrical and optical connection
- Test methods - Part 613: Optical elements - Impact test**

Série aérospatiale - Organes de connexion électrique et
optique - Méthodes d'essais - Partie 613: Organes optiques
- Résistance à l'impact

Luft- und Raumfahrt - Elektrische und optische
Verbindungselemente - Prüfverfahren - Teil 613: Optische
Elemente - Fallprüfung

This European Standard was approved by CEN on 8 February 2002.

CEN members are bound to comply with the CEN/CENELEC Internal Regulations which stipulate the conditions for giving this European Standard the status of a national standard without any alteration. Up-to-date lists and bibliographical references concerning such national standards may be obtained on application to the Management Centre or to any CEN member.

This European Standard exists in three official versions (English, French, German). A version in any other language made by translation under the responsibility of a CEN member into its own language and notified to the Management Centre has the same status as the official versions.

CEN members are the national standards bodies of Austria, Belgium, Czech Republic, Denmark, Finland, France, Germany, Greece, Iceland, Ireland, Italy, Luxembourg, Malta, Netherlands, Norway, Portugal, Spain, Sweden, Switzerland and United Kingdom.

[SIST EN 2591-613:2004](https://standards.iteh.ai/catalog/standards/sist/d2dbab82-668f-4312-9eb2-7da9d7af4655/sist-en-2591-613-2004)

<https://standards.iteh.ai/catalog/standards/sist/d2dbab82-668f-4312-9eb2-7da9d7af4655/sist-en-2591-613-2004>



EUROPEAN COMMITTEE FOR STANDARDIZATION
COMITÉ EUROPÉEN DE NORMALISATION
EUROPÄISCHES KOMITEE FÜR NORMUNG

Management Centre: rue de Stassart, 36 B-1050 Brussels

Foreword

This document (EN 2591-613:2002) has been prepared by the European Association of Aerospace Manufacturers (AECMA).

After enquiries and votes carried out in accordance with the rules of this Association, this Standard has received the approval of the National Associations and the Official Services of the member countries of AECMA, prior to its presentation to CEN.

This European Standard shall be given the status of a national standard, either by publication of an identical text or by endorsement, at the latest by December 2002, and conflicting national standards shall be withdrawn at the latest by December 2002.

According to the CEN/CENELEC Internal Regulations, the national standards organizations of the following countries are bound to implement this European Standard: Austria, Belgium, Czech Republic, Denmark, Finland, France, Germany, Greece, Iceland, Ireland, Italy, Luxembourg, Malta, Netherlands, Norway, Portugal, Spain, Sweden, Switzerland and the United Kingdom

1 Scope

This standard specifies a method of determining the impact resistance on a hard surface of optical connection elements (including permanent connections) and fibre optic couplers.

It shall be used together with EN 2591-100.

2 Normative references

This European Standard incorporates by dated or undated reference provisions from other publications. These normative references are cited at the appropriate places in the text and the publications are listed hereafter. For dated references, subsequent amendments to or revisions of any of these publications apply to this European Standard only when incorporated in it by amendment or revision. For undated references the latest edition of the publication referred to applies.

EN 2591-100	Aerospace series – Elements of electrical and optical connection – Test methods – Part 100: General ¹⁾
EN 2591-408	Aerospace series – Elements of electrical and optical connection – Test methods – Part 408: Mating and unmating forces ²⁾
EN 2591-601	Aerospace series – Elements of electrical and optical connection – Test methods – Part 601: Optical elements – Insertion loss ²⁾
EN 2591-6101	Aerospace series – Elements of electrical and optical connection – Test methods – Part 6101: Optical elements – Visual examination
TR 4257	Aerospace series – Elements of electrical and optical connection – Relationship between the numbering systems for parts of EN 2591 ³⁾

[SIST EN 2591-613:2004](https://standards.iteh.ai/catalog/standards/sist/d2dbab82-668f-4312-9eb2-7da9d7af4655/sist-en-2591-613-2004)

<https://standards.iteh.ai/catalog/standards/sist/d2dbab82-668f-4312-9eb2-7da9d7af4655/sist-en-2591-613-2004>

3 Preparation of specimens

3.1 Specimens shall be fitted with normal accessories and terminated in accordance with the product standard. Cavities with unterminated contacts shall have filler plugs fitted (where applicable).

If not at standard test conditions, the specimens shall be subjected to standard test conditions and stabilized at these conditions for 24 h as defined in EN 2591-100.

3.2 Unless otherwise specified in the technical specification, the following details shall be stated:

- mounting fixture if other than stated in figure 1;
- type of cable to be used;
- length of pipe and cable, if other than stated in figure 2;
- drop height, if other than stated in table 1;
- number of individual tests (drops) if other than stated in table 1;
- sequence of individual drop tests, if other than stated in table 1;
- severity level, see table 1;
- impact surface (length, width, thickness, material) if other than stated in 4;
- any other deviations from standard test method;
- maximum value of insertion loss.

1) Published as AECMA Prestandard at the date of publication of this standard

2) See TR 4257.

3) Published as AECMA Technical Report at the date of publication of this standard

4 Apparatus

See EN 2591-601 plus:

- a mounting fixture of the type shown in figure 1 shall be used unless otherwise specified. This fixture shall be mounted on an appropriate, stable vertical arrangement at a height of 0,6 m above the plate on which the specimen shall be dropped.

Unless otherwise stated, the impact surface shall be a steel plate at least 300 mm × 500 mm × 25 mm thick.

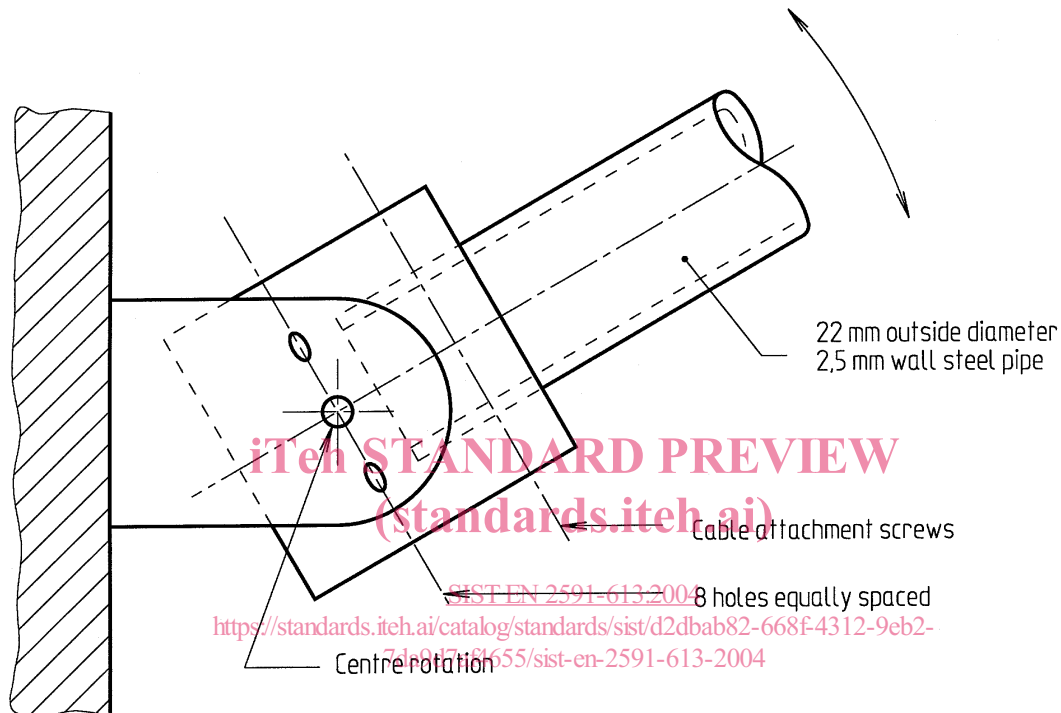

Figure 1

5 Method

5.1 Initial measurements

- EN 2591-6101
- EN 2591-601

5.2 Procedure

The cable plus specimen shall be securely attached to the pipe of the mounting fixture in such a way that the specimen can be held horizontally, at the specified height and is not under tension (see figure 2).

Unless otherwise specified, the cable/specimen arrangement shall be extended to its full length from the mounting fixture and held at the specified height. The specimen shall then be dropped on to the impact surface following a pendulum movement of the pipe and cable. The radial orientation for an individual test (drop) is determined in a series of eight tests using the index position of the mounting fixture. Each individual test shall be performed with another index position which is set by turning clockwise.

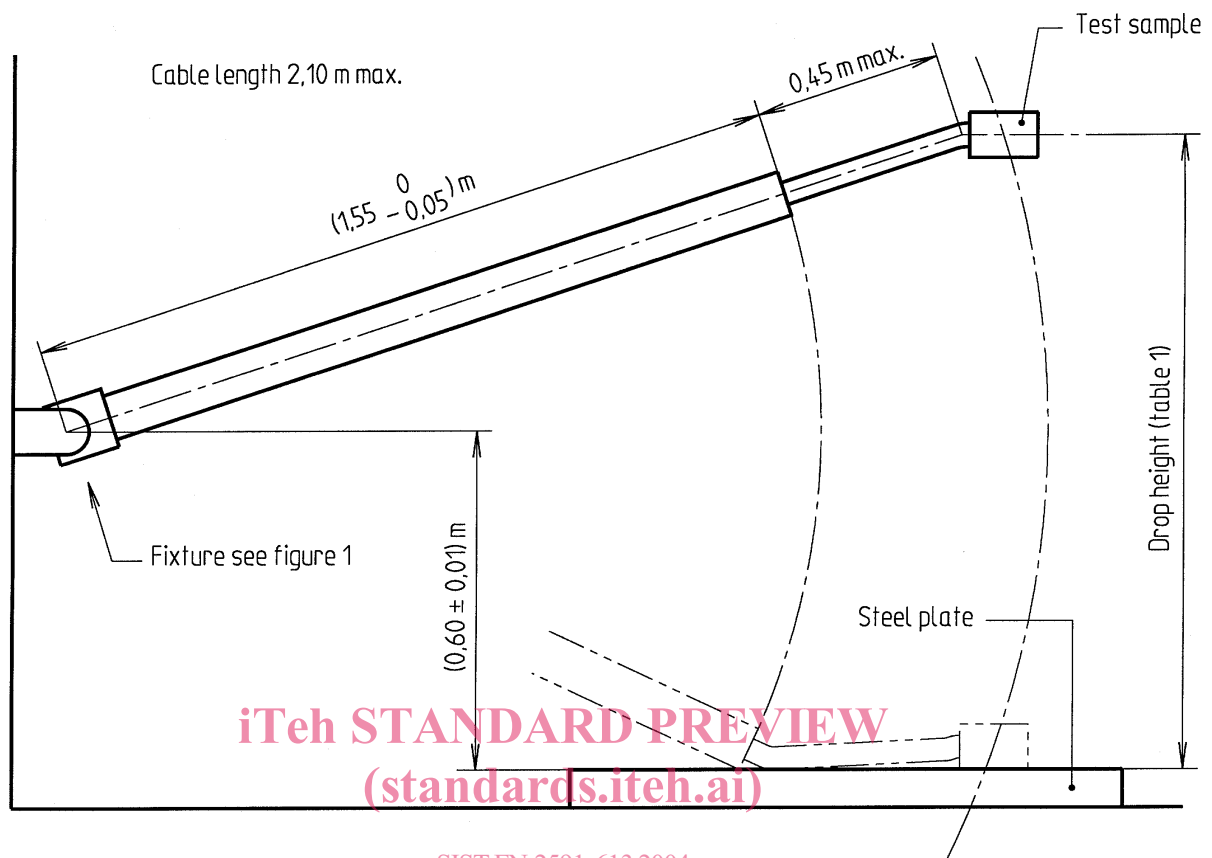

SIST EN 2591-613:2004

<https://standards.iteh.ai/catalog/standards/sist/42dbab82-668f-4312-9eb2-7da9d7af4655/sist-en-2591-613-2004>

Figure 2

Unless otherwise specified, the specimen shall be dropped repeatedly from the specified height in the sequence of severity levels given in table 1 (lowest drop first).

Table 1

Drop height m ± 0,006	Number of individual tests (drops) by severity level	
	light	severe
1,80	8	8
2,40	0	16
Total number of individual tests	8	24

NOTE The first eight drops clear the specimen for "light" use. A further 16 drops from the increased height, following EN 2591-6101, clear the same specimen for "severe" use.

Unless otherwise specified in the product standard, the specimen shall be subjected to EN 2591-6101 after each cycle of eight drops.

5.3 Final measurements and requirements

Unless otherwise specified in the product standard, the specimen shall be subjected to the following tests.

- EN 2591-6101
- EN 2591-601
- EN 2591-408