



Designation: C 885 – 87 (Reapproved 1997)<sup>ε1</sup>

AMERICAN SOCIETY FOR TESTING AND MATERIALS  
100 Barr Harbor Dr., West Conshohocken, PA 19428  
Reprinted from the Annual Book of ASTM Standards. Copyright ASTM

## Standard Test Method for Young's Modulus of Refractory Shapes by Sonic Resonance<sup>1</sup>

This standard is issued under the fixed designation C 885; the number immediately following the designation indicates the year of original adoption or, in the case of revision, the year of last revision. A number in parentheses indicates the year of last reapproval. A superscript epsilon ( $\epsilon$ ) indicates an editorial change since the last revision or reapproval.

<sup>ε1</sup> NOTE—Editorial changes were made in Sections 10 and 11 in November 1997.

### 1. Scope

1.1 This test method covers a procedure for measuring the resonance frequency in the flexural (transverse) mode of vibration of rectangular refractory brick or rectangularly shaped monoliths at room temperature. Young's modulus is calculated from the resonance frequency of the shape, its mass (weight) and dimensions.

1.2 *This standard does not purport to address all of the safety concerns, if any, associated with its use. It is the responsibility of the user of this standard to establish appropriate safety and health practices and determine the applicability of regulatory limitations prior to use.*

### 2. Referenced Documents

#### 2.1 ASTM Standards:

- C 134 Test Methods for Size, Dimensional Measurements, and Bulk Density of Refractory Brick and Insulating Firebrick<sup>2</sup>
- C 215 Test Method for Fundamental Transverse, Longitudinal, and Torsional Frequencies of Concrete Specimens<sup>3</sup>
- C 623 Test Method for Young's Modulus, Shear Modulus, and Poisson's Ratio for Glass and Glass-Ceramics by Resonance<sup>4</sup>
- C 747 Test Method for Moduli of Elasticity and Fundamental Frequencies of Carbon and Graphite Materials by Sonic Resonance<sup>2</sup>
- C 848 Test Method for Young's Modulus, Shear Modulus, and Poisson's Ratio for Ceramic Whitewares by Resonance<sup>4</sup>

### 3. Summary of Test Method

3.1 Test specimens are vibrated in flexure over a broad frequency range; mechanical excitation is provided through the use of a vibrating driver that transforms an initial electrical

signal into a mechanical vibration. A detector senses the resulting mechanical vibrations of the specimen and transforms them into an electrical signal that can be displayed on the screen of an oscilloscope to detect resonance by a Lissajous figure. The calculation of Young's modulus from the resonance frequency measured is simplified by assuming that Poisson's ratio is  $\frac{1}{6}$  for all refractory materials.

### 4. Significance and Use

4.1 Young's modulus is a fundamental mechanical property of a material.

4.2 This test method is used to determine the dynamic modulus of elasticity of rectangular shapes. Since the test is nondestructive, specimens may be used for other tests as desired.

4.3 This test method is useful for research and development, engineering application and design, manufacturing process control, and for developing purchasing specifications.

4.4 The fundamental assumption inherent in this test method is that a Poisson's ratio of  $\frac{1}{6}$  is typical for heterogeneous refractory materials. The actual Poisson's ratio may differ.

### 5. Apparatus

5.1 A block diagram of a suggested test apparatus arrangement is shown in Fig. 1. Details of the equipment are as follows:

5.1.1 *Audio Oscillator*, having a continuously variable calibrated-frequency output from about 50 Hz to at least 10 kHz.

5.1.2 *Audio Amplifier*, having a power output sufficient to ensure that the type of driver used can excite the specimen; the output of the amplifier must be adjustable.

5.1.3 *Driver*, which may consist of a transducer or a loudspeaker from which the cone has been removed and replaced with a probe (connecting rod) oriented parallel to the direction of the vibration; suitable vibration-isolating mounts.

NOTE 1—For small specimens, an air column may preferably be used for "coupling" the loudspeaker to the specimen.

5.1.4 *Detector*, which may be a transducer or a balance-mounted monaural (crystal or magnetic) phonograph pick-up

<sup>1</sup> This test method is under the jurisdiction of ASTM Committee C-8 on Refractories, and is the direct responsibility of Subcommittee C08.01 on Strength Properties.

Current edition approved July 31, 1987. Published August 1987. Originally published as C 885 – 78. Last previous edition C 885 – 81<sup>ε1</sup>.

<sup>2</sup> *Annual Book of ASTM Standards*, Vol 15.01.

<sup>3</sup> *Annual Book of ASTM Standards*, Vol 04.02.

<sup>4</sup> *Annual Book of ASTM Standards*, Vol 15.02.

ASTM C 885

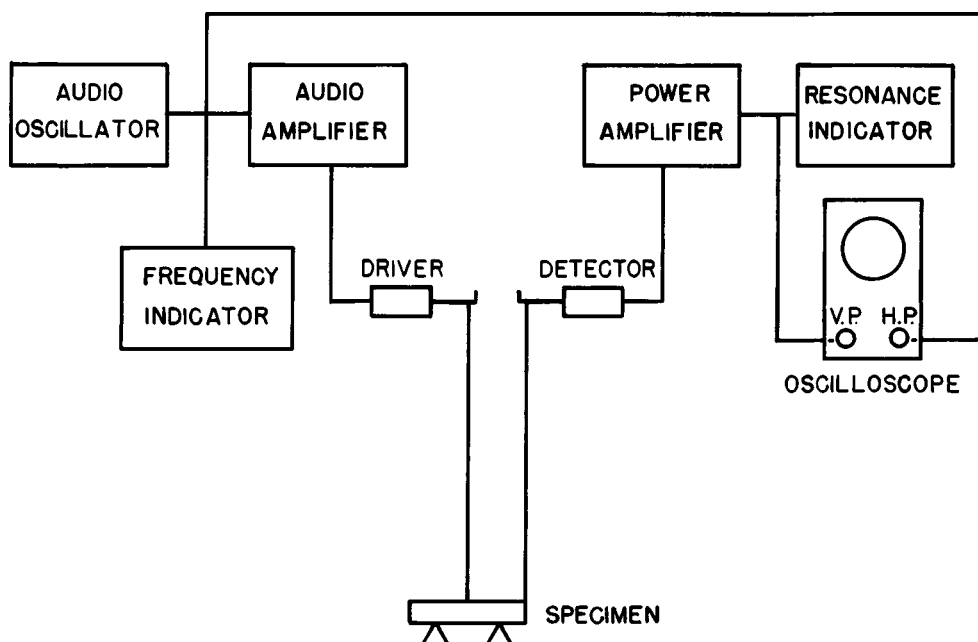

FIG. 1 Block Diagram of Apparatus

cartridge of good frequency response; the detector should be movable across the specimen; suitable vibration-isolating mounts.

5.1.5 *Pre-Scope Amplifier* in the detector circuit, impedance-matched with the detector used; the output must be adjustable.

5.1.6 *Indicating Devices*, including an oscilloscope, a resonance indicator (voltmeter or ammeter), and a frequency indicator, which may be the control dial of the audio-oscillator (accurately readable to  $\pm 30$  Hz or better) or, preferably, a frequency meter, for example, a digital frequency counter.

5.1.7 *Specimen Support*, consisting of two knife edges (can be steel, rubber-coated steel, or medium-hard rubber) of a length at least equal to the width of the specimens; the distance between the knife edges must be adjustable.

NOTE 2—The support for the knife edges may be a foam rubber pad, and should be vibration-isolated from drive and detector supports.

NOTE 3—Alternatively, knife edges can be omitted and the specimen may be placed directly on a foam rubber pad if the test material is easily excitable due to its composition and geometry.

## 6. Sampling and Specimen Preparation

6.1 Specimens must be rectangular prisms. They may be full straight brick or rectangular samples cut from brick shapes; rectangular straight shapes of monolithic refractories, or rectangular specimens cut from monolithic shapes. For best results, their length to thickness ratio should be at least 3 to 1. Maximum specimen size and mass are primarily determined by the test system's energy capability and by the resonance response characteristics of the material. Minimum specimen size and mass are primarily determined by adequate and optimum coupling of the driver and the detector to the specimen, and by the resonance response characteristics of the material. Measure the mass (weight) and dimensions of the dry specimens in accordance with Test Methods C 134 and record.

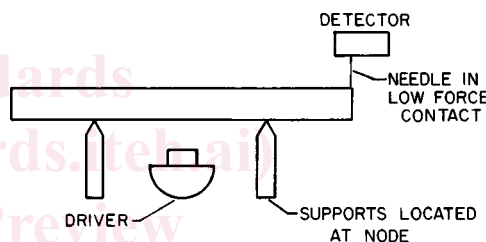

FIG. 2 Typical Specimen Positioning for Measurement of Flexural Resonance

## 7. Procedure

7.1 Refractories can vary markedly in their response to the driver's frequency; the geometry of the specimens also plays a significant role in their response characteristics. Variations in the following procedure are permissible as long as flexural and fundamental resonance are verified (Note 6 and Note 7). Fig. 2 and Fig. 3 illustrate a typical specimen positioning and the desired mode of vibration, respectively.

7.2 *Sample Placement*—Place the specimen “flat” (thickness dimension perpendicular to supports) on parallel knife edges at  $0.224 l$  (where  $l$  is the length of the specimen) from its ends. Optionally, the specimen can be placed on a foam rubber pad.

7.3 *Driver Placement*—Place the driver preferably at the center of the top or bottom face of the specimen using moderate balanced pressure or spring action.

NOTE 4—Especially with small (thin) specimens, the lightest possible driver pressure to ensure adequate “coupling” must be used in order to achieve proper resonance response. In small specimens, exact placement of the driver at the very center of the flat specimen is important; also, an air column may be used for “coupling.”

7.4 *Detector Placement*—Place the detector preferably at one end of the specimen and at the center of either the width or thickness (considering the orientation of maximum response of the detector) using minimal pressure.

**C 885**

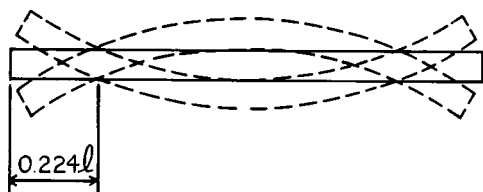

**FIG. 3 Fundamental Mode of Vibration in Flexure (Side View)**

NOTE 5—Make sure that the stylus of the phonograph cartridge (if used) is well secured.

7.5 Activate and warm up the equipment so that power adequate to excite the specimen is delivered to the driver. Set the gain on the detector circuit high enough to detect vibration in the specimen, and to display it on the oscilloscope screen with sufficient amplitude to measure accurately the frequency at which the signal amplitude is maximized. Adjust the oscilloscope so that a sharply defined horizontal baseline exists when the specimen is not excited. Scan frequency with the audio oscillator until fundamental flexural specimen resonance is indicated by an oval to circular Lissajous figure at the oscilloscope and maximum output is shown at the resonance indicator. Record the resonance frequency.

NOTE 6—To verify the flexural mode of vibration, move the detector to the top center of the specimen. The oval or circular oscilloscope pattern shall be maintained. Placement of the detector above the nodal points (at 0.224 *l*) shall cause a Lissajous pattern and high output at the resonance indicator to disappear.

NOTE 7—To verify the fundamental mode of flexural resonance, excite the specimen at one half of the frequency established in 7.5. A “figure eight” Lissajous pattern should appear at the oscilloscope when the detector is placed at the end center or at the top center of the specimen.

**8. Calculation**

8.1 Data determined on individual specimens include:

- 8.1.1 *l* = length of specimen, in.,
- 8.1.2 *b* = width of specimen, in.,
- 8.1.3 *t* = thickness of specimen, in.,
- 8.1.4 *w* = mass (weight) of specimen, lb, and
- 8.1.5 *f* = fundamental flexural resonance frequency, Hz.

8.2 Calculate Young’s modulus *E*, in psi, of the specimen as follows:

$$E = C_1 \cdot w \cdot f^2 \tag{1}$$

where  $C_1 = [C_1b]/b$  (in  $s^2/in.^2$ ) is calculated from values of  $[C_1b]$  listed in Table 1 for various *l/t* ratios based on Pickett’s<sup>5</sup> equations solved for a Poisson’s ratio of 1/6. Alternatively,  $[C_1b]$  can be computed directly from *l* and *t* using Pickett’s original equations and correction factors, as described in Appendix X1.

<sup>5</sup> Pickett, G., “Equations for Computing Elastic Constants from Flexural and Torsional Resonant Frequencies of Vibration of Prisms and Cylinders,” *Proceedings, ASTM*, Vol 45, 1945, pp. 846–863.

**TABLE 1  $[C_1b]$  Values**

<i>l/t</i> $[C_1b]$	<i>l/t</i> $[C_1b]$	<i>l/t</i> $[C_1b]$	<i>l/t</i> $[C_1b]$	<i>l/t</i> $[C_1b]$	<i>l/t</i> $[C_1b]$
2.50 0.0750	3.10 0.1200	3.70 0.1815	4.30 0.2627	4.90 0.3665	5.50 0.4963
2.51 0.0756	3.11 0.1209	3.71 0.1827	4.31 0.2642	4.91 0.3685	5.51 0.4988
2.52 0.0763	3.12 0.1218	3.72 0.1839	4.32 0.2657	4.92 0.3704	5.52 0.5012
2.53 0.0769	3.13 0.1227	3.73 0.1851	4.33 0.2673	4.93 0.3724	5.53 0.5036
2.54 0.0776	3.14 0.1236	3.74 0.1863	4.34 0.2688	4.94 0.3743	5.54 0.5060
2.55 0.0782	3.15 0.1245	3.75 0.1875	4.35 0.2704	4.95 0.3763	5.55 0.5084
2.56 0.0789	3.16 0.1254	3.76 0.1887	4.36 0.2720	4.96 0.3783	5.56 0.5109
2.57 0.0795	3.17 0.1263	3.77 0.1899	4.37 0.2735	4.97 0.3803	5.57 0.5133
2.58 0.0802	3.18 0.1272	3.78 0.1911	4.38 0.2751	4.98 0.3823	5.58 0.5158
2.59 0.0808	3.19 0.1281	3.79 0.1924	4.39 0.2767	4.99 0.3843	5.59 0.5183
2.60 0.0815	3.20 0.1291	3.80 0.1936	4.40 0.2783	5.00 0.3863	5.60 0.5207
2.61 0.0822	3.21 0.1300	3.81 0.1948	4.41 0.2799	5.01 0.3883	5.61 0.5232
2.62 0.0828	3.22 0.1309	3.82 0.1961	4.42 0.2815	5.02 0.3903	5.62 0.5257
2.63 0.0835	3.23 0.1318	3.83 0.1973	4.43 0.2831	5.03 0.3924	5.63 0.5282
2.64 0.0842	3.24 0.1328	3.84 0.1986	4.44 0.2847	5.04 0.3944	5.64 0.5307
2.65 0.0849	3.25 0.1337	3.85 0.1999	4.45 0.2864	5.05 0.3964	5.65 0.5332
2.66 0.0856	3.26 0.1347	3.86 0.2011	4.46 0.2880	5.06 0.3985	5.66 0.5358
2.67 0.0863	3.27 0.1356	3.87 0.2024	4.47 0.2896	5.07 0.4005	5.67 0.5383
2.68 0.0870	3.28 0.1366	3.88 0.2037	4.48 0.2913	5.08 0.4026	5.68 0.5408
2.69 0.0877	3.29 0.1376	3.89 0.2050	4.49 0.2929	5.09 0.4047	5.69 0.5434
2.70 0.0884	3.30 0.1385	3.90 0.2062	4.50 0.2946	5.10 0.4068	5.70 0.5459
2.71 0.0891	3.31 0.1395	3.91 0.2075	4.51 0.2963	5.11 0.4089	5.71 0.5485
2.72 0.0898	3.32 0.1405	3.92 0.2088	4.52 0.2979	5.12 0.4110	5.72 0.5511
2.73 0.0905	3.33 0.1415	3.93 0.2101	4.53 0.2996	5.13 0.4131	5.73 0.5537
2.74 0.0912	3.34 0.1425	3.94 0.2115	4.54 0.3013	5.14 0.4152	5.74 0.5562
2.75 0.0920	3.35 0.1435	3.95 0.2128	4.55 0.3030	5.15 0.4173	5.75 0.5588
2.76 0.0927	3.36 0.1445	3.96 0.2141	4.56 0.3047	5.16 0.4194	5.76 0.5615
2.77 0.0934	3.37 0.1455	3.97 0.2154	4.57 0.3064	5.17 0.4216	5.77 0.5641
2.78 0.0942	3.38 0.1465	3.98 0.2168	4.58 0.3081	5.18 0.4237	5.78 0.5667
2.79 0.0949	3.39 0.1475	3.99 0.2181	4.59 0.3098	5.19 0.4258	5.79 0.5693
2.80 0.0957	3.40 0.1485	4.00 0.2194	4.60 0.3116	5.20 0.4280	5.80 0.5720
2.81 0.0964	3.41 0.1496	4.01 0.2208	4.61 0.3133	5.21 0.4302	5.81 0.5746