**Textiles — Test methods for
evaluating the electrostatic
propensity of fabrics —**

**Part 2:
Test method using rotary mechanical
friction**

iTeh STANDARD PREVIEW

(standards.iteh.ai)
*Textiles — Méthodes d'essai pour l'évaluation de la propension des
étoffes électrostatique —*

Partie 2: Méthode d'essai de frottement mécanique rotatif

<https://standards.iteh.ai/catalog/standards/sist/c3a8d157-70a6-41d1-b3fl-51fc266e1936/iso-18080-2-2015>

iTeh STANDARD PREVIEW
(standards.iteh.ai)

ISO 18080-2:2015

<https://standards.iteh.ai/catalog/standards/sist/c3a8d157-70a6-41d1-b3fl-51fc266e1936/iso-18080-2-2015>



COPYRIGHT PROTECTED DOCUMENT

© ISO 2015, Published in Switzerland

All rights reserved. Unless otherwise specified, no part of this publication may be reproduced or utilized otherwise in any form or by any means, electronic or mechanical, including photocopying, or posting on the internet or an intranet, without prior written permission. Permission can be requested from either ISO at the address below or ISO's member body in the country of the requester.

ISO copyright office
Ch. de Blandonnet 8 • CP 401
CH-1214 Vernier, Geneva, Switzerland
Tel. +41 22 749 01 11
Fax +41 22 749 09 47
copyright@iso.org
www.iso.org

Contents

	Page
Foreword.....	iv
Introduction.....	v
1 Scope	1
2 Normative references	1
3 Terms and definitions	1
4 Principle	2
5 Conditioning and testing atmosphere	2
6 Apparatus	2
7 Preparation of specimen	4
7.1 Sampling.....	4
7.2 Cleansing of sample.....	4
7.2.1 General.....	4
7.2.2 Wash by water.....	4
7.2.3 Dry cleaning.....	5
7.3 Conditioning of sample.....	5
8 Preparation for the apparatus	5
8.1 Specimen thickness.....	5
8.2 Adjustment of the height of detector electrode.....	5
8.3 Adjustment of the height of rubbing cloth clamps.....	5
8.4 Connection to recording device.....	5
9 Testing method	5
10 Test report	6
Annex A (informative) Interpretation of the test result	7
Annex B (informative) Round robin test result	8
Bibliography	14

Foreword

ISO (the International Organization for Standardization) and IEC (the International Electrotechnical Commission) are worldwide federations of national standards bodies (ISO member bodies and IEC national committees). The work of preparing International Standards is normally carried out through ISO and IEC technical committees. Each member body interested in a subject for which a technical committee has been established has the right to be represented on that committee. International organizations, governmental and non-governmental, in liaison with ISO, also take part in the work. ISO collaborates closely with IEC on all matters of electrotechnical standardization.

The procedures used to develop this document and those intended for its further maintenance are described in the ISO/IEC Directives, Part 1. In particular the different approval criteria needed for the different types of ISO documents should be noted. This document was drafted in accordance with the editorial rules of the ISO/IEC Directives, Part 2 (see www.iso.org/directives).

Attention is drawn to the possibility that some of the elements of this document may be the subject of patent rights. ISO shall not be held responsible for identifying any or all such patent rights. Details of any patent rights identified during the development of the document will be in the Introduction and/or on the ISO list of patent declarations received (see www.iso.org/patents).

Any trade name used in this document is information given for the convenience of users and does not constitute an endorsement.

For an explanation on the meaning of ISO specific terms and expressions related to conformity assessment, as well as information about ISO's adherence to the WTO principles in the Technical Barriers to Trade (TBT) see the following URL: [Foreword - Supplementary information](#)

The committees responsible for this document are Technical Committee ISO/TC 38, *Textiles* and IEC/TC 101 *Electrostatics* as JWG 26, *Antistatic*, in the lead of ISO/TC 38.

ISO 18080 consists of the following parts under the general title *Textiles — Test methods for evaluating the electrostatic propensity of fabrics*:

- *Part 1: Test method using corona charging*
- *Part 2: Test method using rotary mechanical friction*
- *Part 3: Test method using manual friction*
- *Part 4: Test method using horizontal mechanical friction*

Introduction

In addition to safety hazards and damage or disruption of sensitive electronic devices and systems which are covered by other International Standards, electrostatic charging of clothing can also cause problems of clinging, uncomfortable shocks and the attraction of airborne dust and other contaminants.

Clothing designed to avoid airborne dust contamination is required in a number of expanding industries relating to precision technology, biotechnology, food, hygiene, etc. It is also generally desirable to have clothing that does not cling or cause uncomfortable shocks.

Test methods are required to evaluate the propensity of fabrics used to make clothing designed to avoid problems associated with electrostatic charging. Test methods are specified in a number of National and International Standards, including those published by ISO and IEC. However, the relationship between measurable electrostatic properties and end use performance is rather complex and may require a combination of different test methods depending on application.

The test method described in this International Standard is one of a number of test methods that can be used to evaluate the electrostatic propensity of textile materials. Definitive performance requirements are not given, but guidance on the interpretation of results is given in informative Annex A. The qualitative interpretation scheme is based on anecdotal experience in industry in controlling clinging, uncomfortable shocks and attraction of particulate contaminants. Nevertheless, it is provided for guidance only and users of this International Standard are advised to check its validity for their own applications.

This test method simulates electrostatic charging typically experienced in wearing conditions. The standard rubbing cloths and mechanical conditions have been selected from long experience.

ITEH STANDARD PREVIEW
(standards.iteh.ai)
ISO 18080-2:2015
<https://standards.iteh.ai/catalog/standards/sist/c3a8d157-70a6-41d1-b3f1-51fc266e1936/iso-18080-2-2015>

iTeh STANDARD PREVIEW
(standards.iteh.ai)

[ISO 18080-2:2015](https://standards.iteh.ai/catalog/standards/sist/c3a8d157-70a6-41d1-b3f1-51fc266e1936/iso-18080-2-2015)

<https://standards.iteh.ai/catalog/standards/sist/c3a8d157-70a6-41d1-b3f1-51fc266e1936/iso-18080-2-2015>

Textiles — Test methods for evaluating the electrostatic propensity of fabrics —

Part 2: Test method using rotary mechanical friction

1 Scope

This part of ISO 18080 specifies a test method using rotary mechanical friction with measurement of the friction-charged electrostatic potential on specimens of fabric. The test method is suitable for fabrics of all types of composition and construction that are capable of withstanding frictional charging.

Some fabrics, e.g. fabrics of low strength or loose construction, may not be physically capable of withstanding the mechanical friction used in this test method or may give false results. In such cases, the test method described in ISO 18080-1 can be used to evaluate electrostatic propensity.

The test method described may not be suitable for evaluating garments and garment materials in relation to safety of personnel and protection of electrostatic discharge sensitive devices.

iTeh STANDARD PREVIEW

2 Normative references (standards.iteh.ai)

The following documents, in whole or in part, are normatively referenced in this document and are indispensable for its application. For dated references, only the edition cited applies. For undated references, the latest edition of the referenced document (including any amendments) applies.

ISO 105-F01, *Textiles — Tests for colour fastness — Part F01: Specification for wool adjacent fabric*

ISO 105-F02, *Textiles — Tests for colour fastness — Part F02: Specification for cotton and viscose adjacent fabrics*

ISO 3175-2, *Textiles — Professional care, drycleaning and wetcleaning of fabrics and garments — Part 2: Procedure for testing performance when cleaning and finishing using tetrachloroethene*

ISO 3175-3, *Textiles — Professional care, drycleaning and wetcleaning of fabrics and garments — Part 3: Procedure for testing performance when cleaning and finishing using hydrocarbon solvents*

ISO 5084, *Textiles — Determination of thickness of textiles and textile products*

ISO 6330, *Textiles — Domestic washing and drying procedures for textile testing*

3 Terms and definitions

For the purposes of this document, the following terms and definitions apply.

3.1

antistatic

property of a material that reduces its propensity to acquire electrostatic charges or allows electrostatic charges to dissipate quickly

3.2

friction-charged electrostatic potential

potential generated on a material by friction with another or same material obtained as voltage

3.3 conductive

providing a sufficiently high conductivity so that potential differences over any parts of a material or object are not sufficiently large as to be of practical significance

Note 1 to entry: In general, a conductive material has a resistance below about $10^5 \Omega$, but different standards may define different resistance ranges for this term.

4 Principle

A fabric specimen is mounted on a rotary drum and mechanically rubbed against a stationary rubbing cloth as the drum rotates. The electrostatic potential caused by the friction between the specimen and the rubbing cloth is measured by a detector electrode during the rotation cycle.

5 Conditioning and testing atmosphere

Unless otherwise agreed or specified, the atmosphere for conditioning and testing shall be a temperature of $(20 \pm 2) ^\circ\text{C}$ and a relative humidity of $(40 \pm 4) \%$. If a different temperature or humidity is used for conditioning or testing, record it in the test report.

NOTE For measurements, refer to ISO 139.

6 Apparatus

iTeh STANDARD PREVIEW

6.1 **Testing apparatus**, one possible test apparatus is shown in [Figures 1](#) to [3](#) as an example with further details shown below. Other apparatus may also be used after appropriate validation.

6.2 **Rotary drum** ([Figure 1](#), key 5), aluminium drum with specimen mounting holders. The outside diameter of the drum is $150 \text{ mm} \pm 1 \text{ mm}$, the width is $60 \text{ mm} \pm 1 \text{ mm}$, and it is rotated at $(400 \pm 1) \text{ rpm}$ by a motor.

— **Mounting pedestal for specimen** ([Figure 1](#), key 3, and [Figure 2](#)), made from a metal frame with an insulating plastic insert such as polytetrafluoroethylene, the surface of which is level with the upper edge of the metal frame and of the same radius of curvature.

NOTE [Figure 1](#) shows a drum fitted with four mounting pedestals. This is necessary to keep the drum in balance as it rotates. Only one pedestal is used for mounting the test specimen.

— **Specimen cover** ([Figure 3](#)), made of stainless steel with a thickness of $1 \text{ mm} \pm 0,1 \text{ mm}$.

— **Friction position** (shown in [Figure 1](#)), a rubbing cloth (key 1) of $25 \text{ mm} \pm 1 \text{ mm}$ width by $150 \text{ mm} \pm 1 \text{ mm}$ length is held by clamps (key 2) at both ends with a distance of $130 \text{ mm} \pm 3 \text{ mm}$ between the clamps and held in tension by a load of $4,9 \text{ N} \pm 0,1 \text{ N}$ (key 6). The vertical distance between the rubbing cloth surface and a horizontal line tangential to the specimen pedestal surface shall be $1,0 \text{ mm} \pm 0,1 \text{ mm}$ measured at the left side clamp and $3,0 \text{ mm} \pm 0,1 \text{ mm}$ measured at the right side clamp.

— **Detector electrode** ([Figure 1](#), key 4) a plate type field sensor with a plate diameter of $20 \text{ mm} \pm 1 \text{ mm}$, measurement range from 0 kV to 10 kV with an accuracy of $\pm 5 \%$, and response time less than 7 ms. Other types of electrostatic fieldmeters or non-contacting voltmeters of suitable dimensions can be used.

Dimensions in millimetres

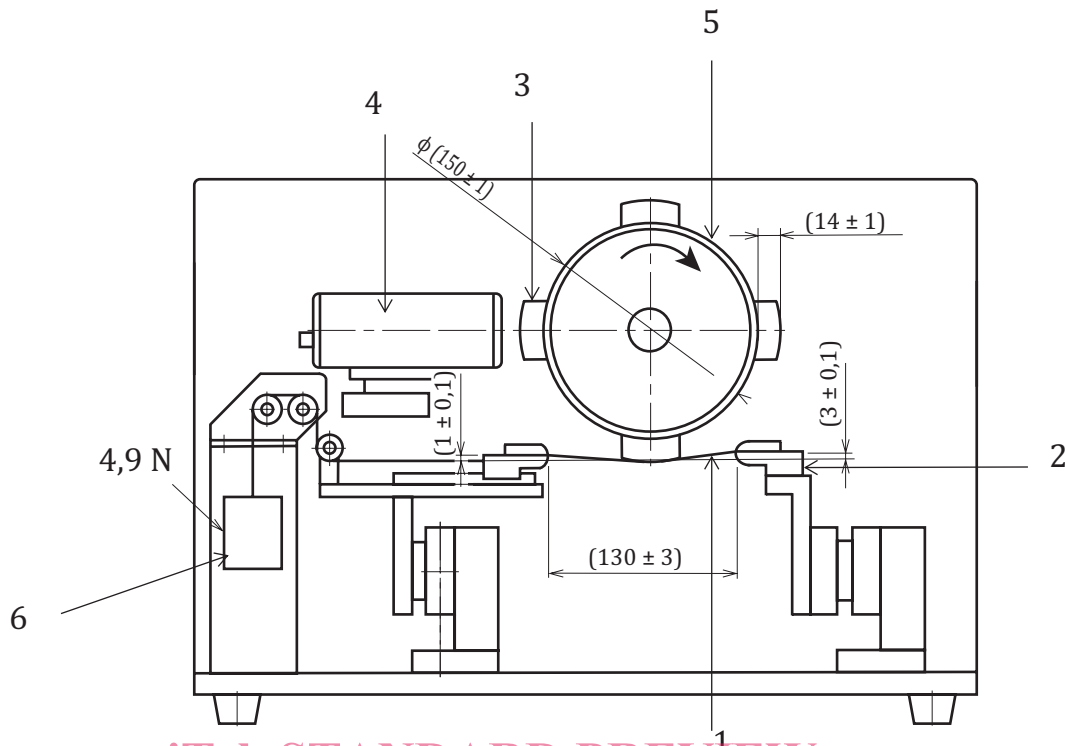

iTeh STANDARD PREVIEW
(standards.iteh.ai)

Key

- 1 rubbing cloth
- 2 clamp for rubbing cloth
- 3 mounting pedestal for specimen (only one pedestal is used for mounting the test specimen)
- 4 detector electrode
- 5 rotary drum
- 6 load (tolerance: $\pm 0,1\text{ N}$)

Figure 1 — Example of a testing apparatus

Dimensions in millimetres

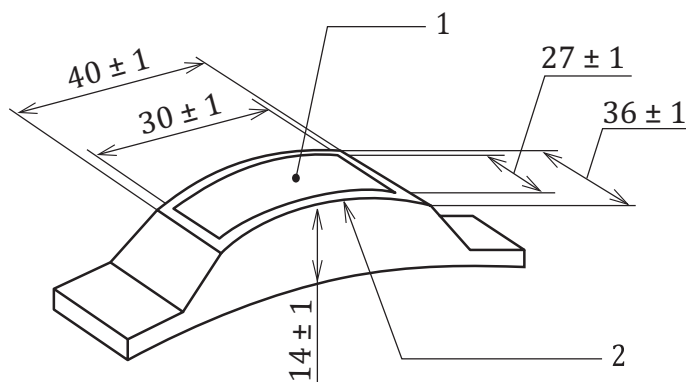

Key

- 1 insulating plastic pedestal
- 2 metal frame with a radius of curvature approximately $90\text{ mm} \pm 1\text{ mm}$

Figure 2 — Mounting pedestal

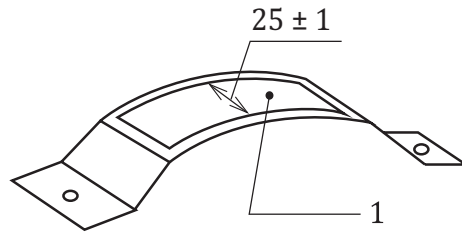

Key

- 1 open space (25 mm ± 1 mm width by 30 mm ± 1 mm length)

Figure 3 — Specimen cover

Metal and other conductive components of the test apparatus shall be connected to the ground with a resistance to the ground of less than 10 Ω.

6.3 Recording device.

6.4 Static electricity elimination equipment, self-discharge type or superimposed voltage type.

6.5 Rubbing cloth, wool and cotton standard adjacent fabrics specified in ISO 105-F01 and ISO 105-F02.

If other rubbing cloths are used, a complete description shall be included in the test report.

6.6 Oven, used to dry samples at (70 ± 3) °C.

iTeH STANDARD PREVIEW
(standards.iteh.ai)

[ISO 18080-2:2015](https://standards.iteh.ai/catalog/standards/sist/c3a8d157-70a6-41d1-b3fl-51fc266e1936/iso-18080-2-2015)

<https://standards.iteh.ai/catalog/standards/sist/c3a8d157-70a6-41d1-b3fl-51fc266e1936/iso-18080-2-2015>

7 Preparation of specimen

7.1 Sampling

7.1.1 Prepare a sample for the test from a fabric roll or clothing.

7.1.2 Careful handling and the use of clean, lint free gloves is recommended to avoid contaminating the samples.

7.2 Cleansing of sample

7.2.1 General

In case cleansing of the samples is required, use one of the following procedures.

If the procedure used for cleansing differs from those detailed below, either in the method, number of cycles, or any other condition, details of such deviations shall be included in the test report.

7.2.2 Wash by water

Wash the samples three cycles according to ISO 6330 Procedure 4 N or 4 M at 40 °C water temperature using reference detergent according to ISO 6330. Dry them by one of the natural drying procedures according to ISO 6330.

Residual detergent from previous use of the washing machine can affect test results. Careful cleaning of the washing machine before use is recommended.

7.2.3 Dry cleaning

Dry clean samples through three cycles according to ISO 3175-2 or ISO 3175-3.

7.3 Conditioning of sample

Condition samples as follows:

- dry two samples for one hour at 70 °C;
- place the samples in the conditioning atmosphere specified in [Clause 5](#) for at least 24 h.

8 Preparation for the apparatus

8.1 Specimen thickness

Measure the thickness (t mm) of the specimen to be tested according to ISO 5084.

8.2 Adjustment of the height of detector electrode

Adjust the distance from the detector electrode to the surface of specimen cover on the mounting pedestal ([Figure 1](#), key 4) to be $15 \text{ mm} + t \text{ mm}$.

8.3 Adjustment of the height of rubbing cloth clamps

The standard clamp positions over horizontal tangent line are $1 \text{ mm} \pm 0,1 \text{ mm}$ for left clamp and $3 \text{ mm} \pm 0,1 \text{ mm}$ for right clamp. According to the thickness of specimen, adjust the height of clamps down by the amount of the specimen thickness (t).

For the left clamp position: $1 \text{ mm} - t \text{ mm}$

For the right clamp position: $3 \text{ mm} - t \text{ mm}$

8.4 Connection to recording device

Connect the apparatus to recording device.

9 Testing method

9.1 After conditioning as specified in [7.3](#), cut five test specimens from the sample of dimensions $50 \text{ mm} \pm 1 \text{ mm}$ by $80 \text{ mm} \pm 1 \text{ mm}$ with the longer dimension in the direction of the warp in woven fabrics, the wale in knitted fabrics, or machine direction in nonwoven fabrics. Cut a further five specimens with the longer dimension in the direction of the weft in woven fabrics, the course in knitted fabrics, and the cross direction in nonwoven fabrics.

9.2 After conditioning as specified in [7.3](#), cut 10 pieces of each type of rubbing cloth of dimensions $150 \text{ mm} \pm 1 \text{ mm}$ by $25 \text{ mm} \pm 1 \text{ mm}$ with the longer dimension in the warp direction.

9.3 Eliminate static electricity from the specimen and rubbing cloth by using static electricity elimination equipment ([6.4](#)).

9.4 Set the rubbing cloth ([Figure 1](#), key 1) in the clamps ([Figure 1](#), key 2) and ensure the position of the clamps is adjusted as specified in [8.3](#).