



SLOVENSKI STANDARD SIST EN 4165-006:2009

01-april-2009

5 YfcbUj h_U! ?cbY_lcf [ZYY_hf] b]ždfUj c_ctb]ža cXi `Urb]!'GHUbuXY'cj bU
hYa dYfUi fU%#) š7 '!\$\$* "XY. Jh 'n&U]('a cXi `žgYf]U&!'GHUbuX'X'nUdfc]nj cX

Aerospace series - Connectors, electrical, rectangular, modular - Operating temperature 175 °C continuous - Part 006: Plug for 2 and 4 modules, series 2 - Product standard

Luft- und Raumfahrt - Elektrischer Rechtecksteckverbinder in modularer Bauweise - Betriebstemperatur 175 °C konstant - Teil 006: Freier Steckverbinder mit 2 und 4 Modulen, Serie 2 - Produktnorm

ITEH STANDARD PREVIEW
(standards.iteh.ai)

Série aérospatiale - Connecteurs électriques modulaires - Températures d'utilisation 175°C continu - Partie 006 : Fiches 2 et 4 modules, série 2 - Norme de produit

SIST EN 4165-006:2009
<https://standards.iteh.ai/catalog/standards/sist/19060/d7-3cca-4194-9c68/05f0e53bdab0/sist-en-4165-006-2009>

Ta slovenski standard je istoveten z: EN 4165-006:2007

ICS:

49.060 Š^æp \ æš Á^• [|b \ æ Aerospace electric
^|\ dã } æ] !^ { æš Áã c { ã equipment and systems

SIST EN 4165-006:2009

en,de

iTeh STANDARD PREVIEW
(standards.iteh.ai)

SIST EN 4165-006:2009

<https://standards.iteh.ai/catalog/standards/sist/196b67d7-3eca-4194-9cb8-05f0e53bdab0/sist-en-4165-006-2009>

EUROPEAN STANDARD

EN 4165-006

NORME EUROPÉENNE

EUROPÄISCHE NORM

April 2007

ICS 49.060

English Version

Aerospace series - Connectors, electrical, rectangular, modular -
Operating temperature 175 °C continuous - Part 006: Plug for 2
and 4 modules, series 2 - Product standard

Série aéronautique - Connecteurs électriques modulaires -
Températures d'utilisation 175 °C continu - Partie 006 :
Fiches 2 et 4 modules, série 2 - Norme de produit

Luft- und Raumfahrt - Elektrischer Rechtecksteckverbinder
in modularer Bauweise - Betriebstemperatur 175 °C
konstant - Teil 006: Freier Steckverbinder mit 2 und 4
Modulen, Serie 2 - Produktnorm

This European Standard was approved by CEN on 30 September 2005.

CEN members are bound to comply with the CEN/CENELEC Internal Regulations which stipulate the conditions for giving this European Standard the status of a national standard without any alteration. Up-to-date lists and bibliographical references concerning such national standards may be obtained on application to the CEN Management Centre or to any CEN member.

This European Standard exists in three official versions (English, French, German). A version in any other language made by translation under the responsibility of a CEN member into its own language and notified to the CEN Management Centre has the same status as the official versions.

CEN members are the national standards bodies of Austria, Belgium, Bulgaria, Cyprus, Czech Republic, Denmark, Estonia, Finland, France, Germany, Greece, Hungary, Iceland, Ireland, Italy, Latvia, Lithuania, Luxembourg, Malta, Netherlands, Norway, Poland, Portugal, Romania, Slovakia, Slovenia, Spain, Sweden, Switzerland and United Kingdom.



EUROPEAN COMMITTEE FOR STANDARDIZATION
COMITÉ EUROPÉEN DE NORMALISATION
EUROPÄISCHES KOMITEE FÜR NORMUNG

Management Centre: rue de Stassart, 36 B-1050 Brussels

Contents

Page

Foreword.....	3
1 Scope	4
2 Normative references	4
3 Terms and definitions	4
4 Required characteristics	4
5 Clicker-nut plug.....	5
5.1 For 2 modules classes W, F, J, M and A	5
5.2 For 4 modules classes W, F, J, M and A	6
5.3 Plug class	6
6 Designation	8
7 Marking	8
8 Technical specification	8

iTeh STANDARD PREVIEW
(standards.iteh.ai)

[SIST EN 4165-006:2009](https://standards.iteh.ai/catalog/standards/sist/196b67d7-3eca-4194-9cb8-05f0e53bdab0/sist-en-4165-006-2009)

<https://standards.iteh.ai/catalog/standards/sist/196b67d7-3eca-4194-9cb8-05f0e53bdab0/sist-en-4165-006-2009>

Foreword

This document (EN 4165-006:2007) has been prepared by the Aerospace and Defence Industries Association of Europe - Standardization (ASD-STAN).

After enquiries and votes carried out in accordance with the rules of this Association, this Standard has received the approval of the National Associations and the Official Services of the member countries of ASD, prior to its presentation to CEN.

This European Standard shall be given the status of a national standard, either by publication of an identical text or by endorsement, at the latest by October 2007, and conflicting national standards shall be withdrawn at the latest by October 2007.

Attention is drawn to the possibility that some of the elements of this document may be the subject of patent rights. CEN [and/or CENELEC] shall not be held responsible for identifying any or all such patent rights.

According to the CEN/CENELEC Internal Regulations, the national standards organizations of the following countries are bound to implement this European Standard: Austria, Belgium, Bulgaria, Cyprus, Czech Republic, Denmark, Estonia, Finland, France, Germany, Greece, Hungary, Iceland, Ireland, Italy, Latvia, Lithuania, Luxembourg, Malta, Netherlands, Norway, Poland, Portugal, Romania, Slovakia, Slovenia, Spain, Sweden, Switzerland and the United Kingdom.

ITIH STANDARD PREVIEW
(standards.iteh.ai)

[SIST EN 4165-006:2009](https://standards.iteh.ai/catalog/standards/sist/196b67d7-3eca-4194-9cb8-05f0e53bdab0/sist-en-4165-006-2009)

<https://standards.iteh.ai/catalog/standards/sist/196b67d7-3eca-4194-9cb8-05f0e53bdab0/sist-en-4165-006-2009>

EN 4165-006:2007 (E)**1 Scope**

This standard defines the plug series 2, for 2 and 4 modules used in the family of rectangular electrical connectors. The receptacles corresponding to those plugs are defined in EN 4165-002.

2 Normative references

The following referenced documents are indispensable for the application of this document. For dated references, only the edition cited applies. For undated references, the latest edition of the referenced document (including any amendments) applies.

EN 2424, *Aerospace series – Marking of aerospace products.*

EN 4165-001, *Aerospace series – Connectors, electrical, rectangular, modular – Operating temperature 175 °C continuous – Part 001: Technical specification.*

EN 4165-002, *Aerospace series – Connectors, electrical, rectangular, modular – Operating temperature 175 °C continuous – Part 002: Specification of performance and contact arrangements.*

EN 4165-021, *Aerospace series – Connectors, electrical, rectangular, modular – Operating temperature 175 °C continuous – Part 021: Coupling system keyway for plug – Product standard.*

3 Terms and definitions

For the purposes of this document, the terms and definitions given in EN 4165-001 apply.

4 Required characteristics

See Figure 1 and Table 1 for 2 modules.

See Figure 2 and Table 2 for 4 modules.

ITeh STANDARD PREVIEW

(standards.iteh.ai)

[SIST EN 4165-006:2009](https://standards.iteh.ai/catalog/standards/sist/196b67d7-3eca-4194-9cb8-05f0e53bdab0/sist-en-4165-006-2009)

<https://standards.iteh.ai/catalog/standards/sist/196b67d7-3eca-4194-9cb8-05f0e53bdab0/sist-en-4165-006-2009>

5 Clicker-nut plug

5.1 For 2 modules classes W, F, J, M and A

Dimensions are in millimetres.

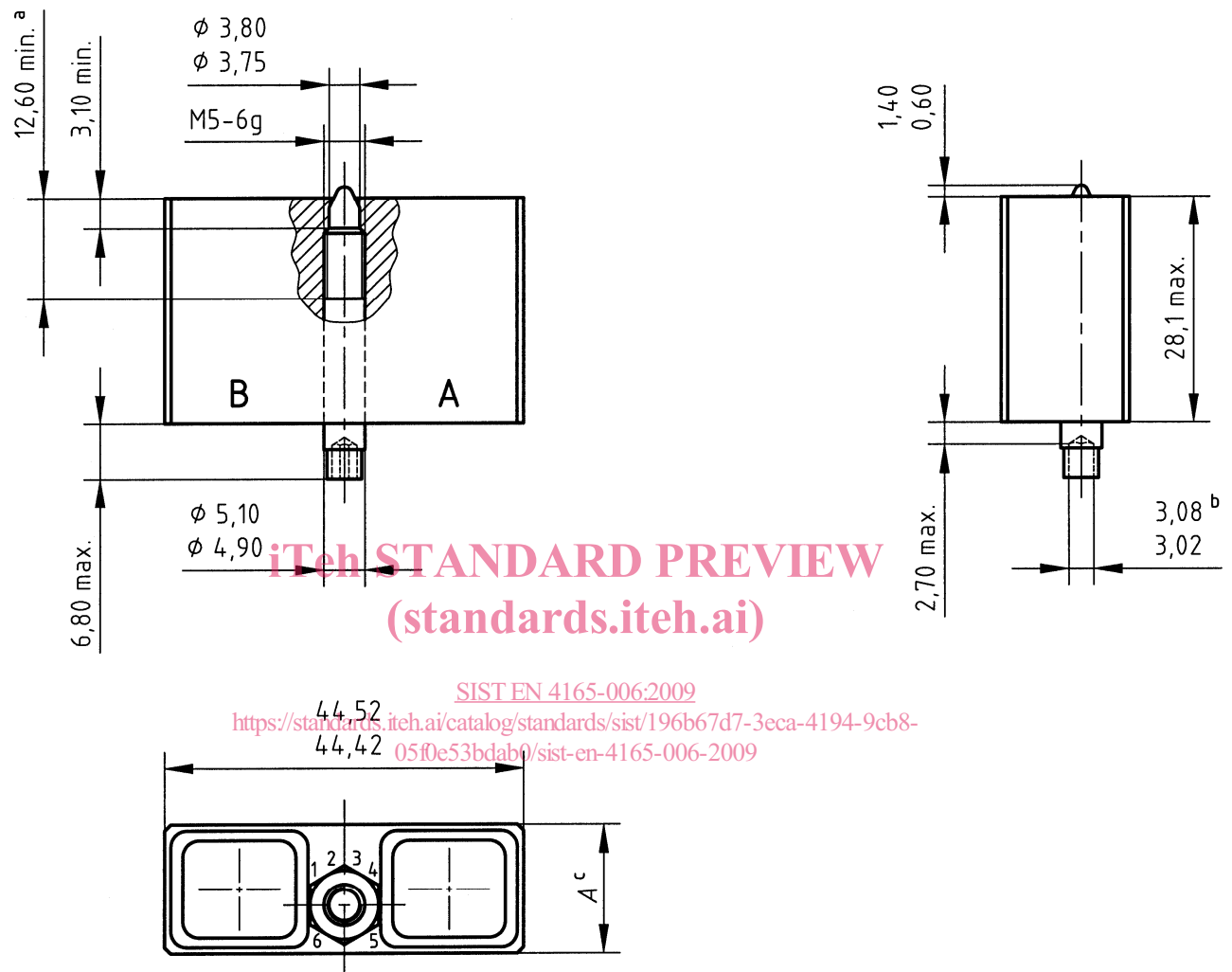

Figure 1

Table 1

Class	A max.
W, F, A	15,10
J, M	15,90

EN 4165-006:2007 (E)

5.2 For 4 modules classes W, F, J, M and A

Dimensions are in millimetres.

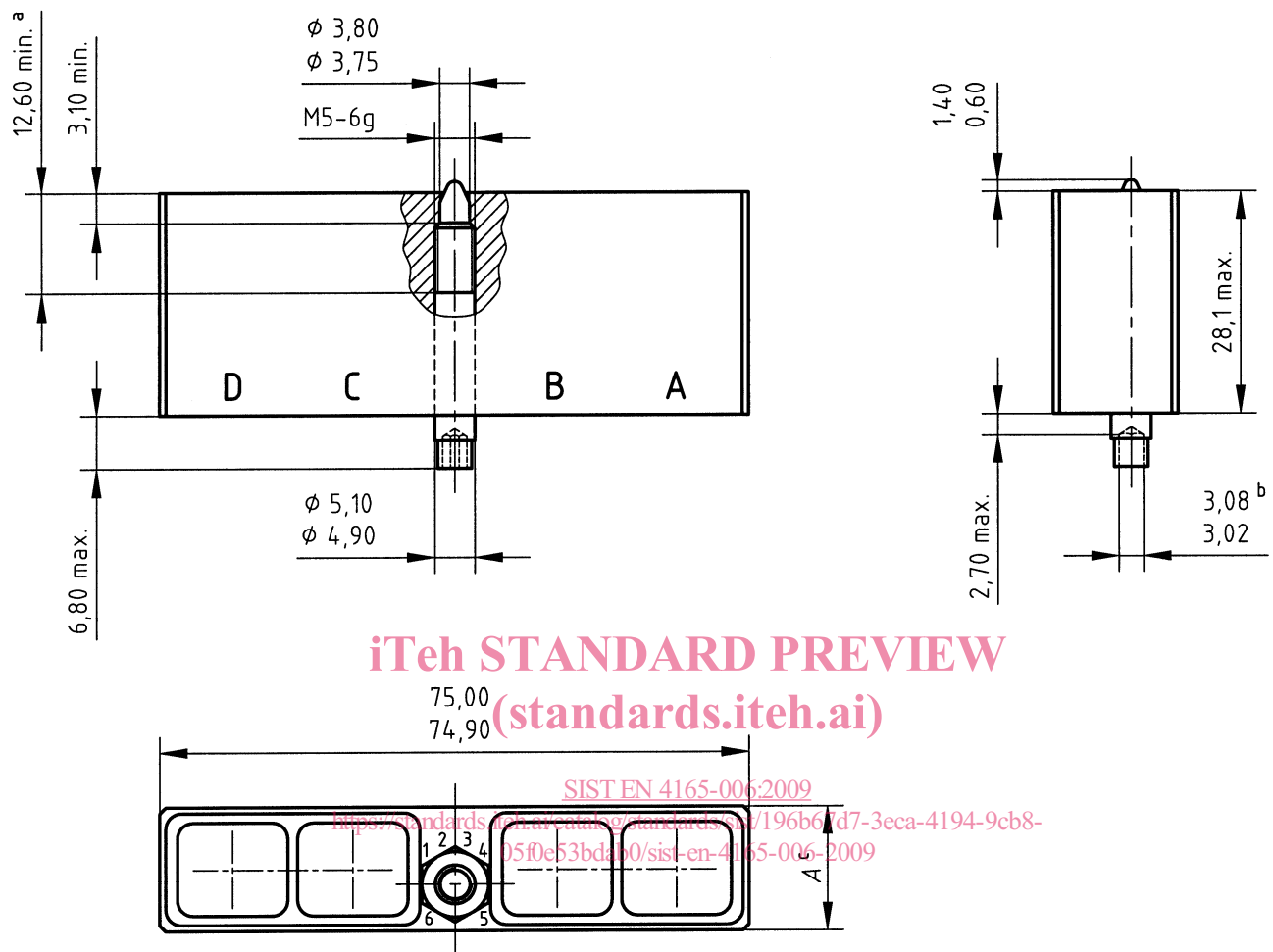

Key

- a active thread
- b hexagonal drive
- c see Table 2.

Figure 2

Table 2

Class	A max.
W, F, A	15,10
J, M	15,90

5.3 Plug class

See Table 3.

Table 3

Class	Description
W	Plug with housing (shell) olive drab cadmium plated, aluminium alloy, conductive finish, 500 hours resistance to salt mist, maximum operating temperature 175 °C continuous
F	Plug with housing (shell) black nickel plated, aluminium alloy, 96 hours resistance to salt mist, maximum operating temperature 175 °C continuous
J	Plug with housing (shell) olive drab cadmium plated, composite material, conductive finish, 500 hours resistance to salt mist, maximum operating temperature 175 °C continuous
M	Plug with housing (shell) nickel plated, composite material, conductive finish, 500 hours resistance to salt mist, maximum operating temperature 175 °C continuous
A	Plug with housing (shell) black anodised plated, aluminium alloy, non-conductive finish, 48 hours resistance to salt mist, maximum operating temperature 175 °C continuous

iTeh STANDARD PREVIEW (standards.iteh.ai)

[SIST EN 4165-006:2009](https://standards.iteh.ai/catalog/standards/sist/196b67d7-3eca-4194-9cb8-05f0e53bdab0/sist-en-4165-006-2009)

<https://standards.iteh.ai/catalog/standards/sist/196b67d7-3eca-4194-9cb8-05f0e53bdab0/sist-en-4165-006-2009>