



SLOVENSKI STANDARD
SIST EN 71-1:2000/A9:2004
01-julij-2004

JUfbcgh][fU '!%XY. AY Ubg_Y]b`Zn] UbY`UgfbcgH]!`8cdc`b]c`5-

Safety of Toys - Part 1: Mechanical and physical properties

Sicherheit von Spielzeug - Teil 1: Mechanische und physikalische Eigenschaften

Sécurité des jouets - Partie 1: Propriétés mécaniques et physiques

Ta slovenski standard je istoveten z: EN 71-1:1998/A9:2004

[SIST EN 71-1:2000/A9:2004](https://standards.iteh.ai/catalog/standards/sist/3b1d6a1a-e05f-480d-bcdc-f436dd9ea874/sist-en-71-1-2000-a9-2004)

<https://standards.iteh.ai/catalog/standards/sist/3b1d6a1a-e05f-480d-bcdc-f436dd9ea874/sist-en-71-1-2000-a9-2004>

ICS:

97.200.50 Q|æ^ Toys

SIST EN 71-1:2000/A9:2004 **en,fr,de**

iTeh STANDARD PREVIEW
(standards.iteh.ai)

[SIST EN 71-1:2000/A9:2004](https://standards.iteh.ai/catalog/standards/sist/3b1d6a1a-e05f-480d-bcdc-f436dd9ea874/sist-en-71-1-2000-a9-2004)

<https://standards.iteh.ai/catalog/standards/sist/3b1d6a1a-e05f-480d-bcdc-f436dd9ea874/sist-en-71-1-2000-a9-2004>

EUROPEAN STANDARD
NORME EUROPÉENNE
EUROPÄISCHE NORM

EN 71-1:1998/A9

May 2004

ICS 97.200.50

English version

Safety of Toys - Part 1: Mechanical and physical properties

Sécurité des jouets - Partie 1: Propriétés mécaniques et
physiques

Sicherheit von Spielzeug - Teil 1: Mechanische und
physikalische Eigenschaften

This amendment A9 modifies the European Standard EN 71-1:1998; it was approved by CEN on 2 January 2004.

CEN members are bound to comply with the CEN/CENELEC Internal Regulations which stipulate the conditions for inclusion of this amendment into the relevant national standard without any alteration. Up-to-date lists and bibliographical references concerning such national standards may be obtained on application to the Central Secretariat or to any CEN member.

This amendment exists in three official versions (English, French, German). A version in any other language made by translation under the responsibility of a CEN member into its own language and notified to the Central Secretariat has the same status as the official versions.

CEN members are the national standards bodies of Austria, Belgium, Cyprus, Czech Republic, Denmark, Estonia, Finland, France, Germany, Greece, Hungary, Iceland, Ireland, Italy, Latvia, Lithuania, Luxembourg, Malta, Netherlands, Norway, Poland, Portugal, Slovakia, Slovenia, Spain, Sweden, Switzerland and United Kingdom.

(standards.iteh.ai)

SIST EN 71-1:2000/A9:2004

<https://standards.iteh.ai/catalog/standards/sist/3b1d6a1a-e05f-480d-bcdc-f436dd9ea874/sist-en-71-1-2000-a9-2004>



EUROPEAN COMMITTEE FOR STANDARDIZATION
COMITÉ EUROPÉEN DE NORMALISATION
EUROPÄISCHES KOMITEE FÜR NORMUNG

Management Centre: rue de Stassart, 36 B-1050 Brussels

iTeh STANDARD PREVIEW
(standards.iteh.ai)

SIST EN 71-1:2000/A9:2004

<https://standards.iteh.ai/catalog/standards/sist/3b1d6a1a-e05f-480d-bcdc-f436dd9ea874/sist-en-71-1-2000-a9-2004>

iTeh STANDARD PREVIEW
(standards.iteh.ai)

SIST EN 71-1:2000/A9:2004

<https://standards.iteh.ai/catalog/standards/sist/3b1d6a1a-e05f-480d-bcdc-f436dd9ea874/sist-en-71-1-2000-a9-2004>

iTeh STANDARD PREVIEW
(standards.iteh.ai)

SIST EN 71-1:2000/A9:2004

<https://standards.iteh.ai/catalog/standards/sist/3b1d6a1a-e05f-480d-bcdc-f436dd9ea874/sist-en-71-1-2000-a9-2004>

iTeh STANDARD PREVIEW **(standards.iteh.ai)**

SIST EN 71-1:2000/A9:2004

<https://standards.iteh.ai/catalog/standards/sist/3b1d6a1a-e05f-480d-bcdc-f436dd9ea874/sist-en-71-1-2000-a9-2004>

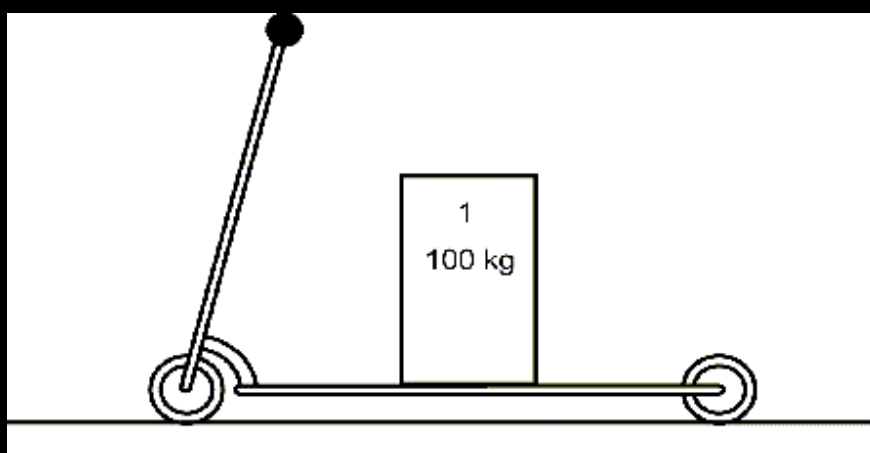

iTeh STANDARD PREVIEW (standards.iteh.ai)

SIST EN 71-1:2000/A9:2004

<https://standards.iteh.ai/catalog/standards/sist/3b1d6a1a-e05f-480d-bcdc-f436dd9ea874/sist-en-71-1-2000-a9-2004>

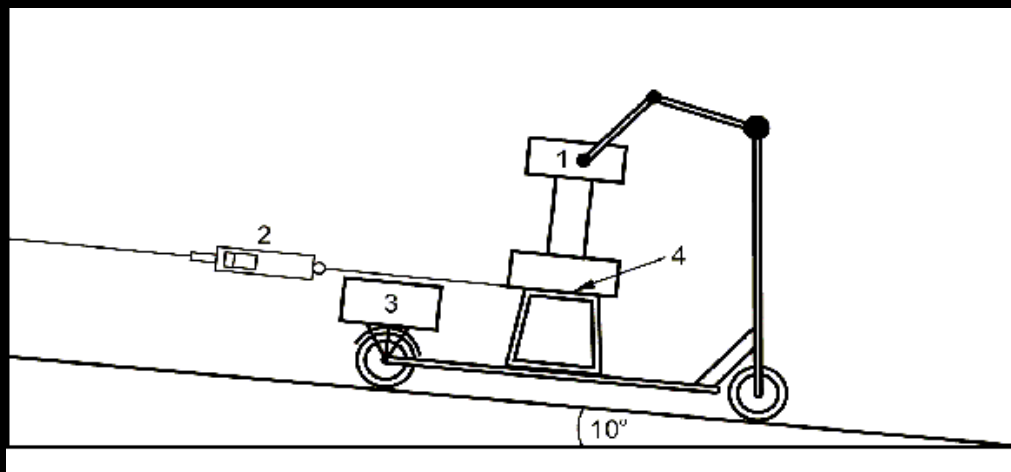

iTeh STANDARD PREVIEW (standards.iteh.ai)

SIST EN 71-1:2000/A9:2004

<https://standards.iteh.ai/catalog/standards/sist/3b1d6a1a-e05f-480d-bcdc-f436dd9ea874/sist-en-71-1-2000-a9-2004>

