

INTERNATIONAL STANDARD

NORME INTERNATIONALE



**Industrial communication networks – Profiles –
Part 5–18: Installation of fieldbuses – Installation profiles for CPF 18**

**Réseaux de communication industriels – Profils –
Partie 5-18: Installation des bus de terrain – Profils d'installation pour CPF 18**

IEC 61784-5-18:2013

<https://standards.iteh.ai/cou/standards/iec/bd/35926-8c62-4c91-b694-ade8337167b2/iec-61784-5-18-2013>



THIS PUBLICATION IS COPYRIGHT PROTECTED
Copyright © 2013 IEC, Geneva, Switzerland

All rights reserved. Unless otherwise specified, no part of this publication may be reproduced or utilized in any form or by any means, electronic or mechanical, including photocopying and microfilm, without permission in writing from either IEC or IEC's member National Committee in the country of the requester.
If you have any questions about IEC copyright or have an enquiry about obtaining additional rights to this publication, please contact the address below or your local IEC member National Committee for further information.

Droits de reproduction réservés. Sauf indication contraire, aucune partie de cette publication ne peut être reproduite ni utilisée sous quelque forme que ce soit et par aucun procédé, électronique ou mécanique, y compris la photocopie et les microfilms, sans l'accord écrit de la CEI ou du Comité national de la CEI du pays du demandeur.
Si vous avez des questions sur le copyright de la CEI ou si vous désirez obtenir des droits supplémentaires sur cette publication, utilisez les coordonnées ci-après ou contactez le Comité national de la CEI de votre pays de résidence.

IEC Central Office
3, rue de Varembe
CH-1211 Geneva 20
Switzerland

Tel.: +41 22 919 02 11
Fax: +41 22 919 03 00
info@iec.ch
www.iec.ch

About the IEC

The International Electrotechnical Commission (IEC) is the leading global organization that prepares and publishes International Standards for all electrical, electronic and related technologies.

About IEC publications

The technical content of IEC publications is kept under constant review by the IEC. Please make sure that you have the latest edition, a corrigenda or an amendment might have been published.

Useful links:

IEC publications search - www.iec.ch/searchpub

The advanced search enables you to find IEC publications by a variety of criteria (reference number, text, technical committee,...).

It also gives information on projects, replaced and withdrawn publications.

IEC Just Published - webstore.iec.ch/justpublished

Stay up to date on all new IEC publications. Just Published details all new publications released. Available on-line and also once a month by email.

Electropedia - www.electropedia.org

The world's leading online dictionary of electronic and electrical terms containing more than 30 000 terms and definitions in English and French, with equivalent terms in additional languages. Also known as the International Electrotechnical Vocabulary (IEV) on-line.

Customer Service Centre - webstore.iec.ch/csc

If you wish to give us your feedback on this publication or need further assistance, please contact the Customer Service Centre: csc@iec.ch.

A propos de la CEI

La Commission Electrotechnique Internationale (CEI) est la première organisation mondiale qui élabore et publie des Normes internationales pour tout ce qui a trait à l'électricité, à l'électronique et aux technologies apparentées.

A propos des publications CEI

Le contenu technique des publications de la CEI est constamment revu. Veuillez vous assurer que vous possédez l'édition la plus récente. un corrigendum ou amendement peut avoir été publié.

Liens utiles:

Recherche de publications CEI - www.iec.ch/searchpub

La recherche avancée vous permet de trouver des publications CEI en utilisant différents critères (numéro de référence, texte, comité d'études,...).

Elle donne aussi des informations sur les projets et les publications remplacées ou retirées.

Just Published CEI - webstore.iec.ch/justpublished

Restez informé sur les nouvelles publications de la CEI. Just Published détaille les nouvelles publications parues. Disponible en ligne et aussi une fois par mois par email.

Electropedia - www.electropedia.org

Le premier dictionnaire en ligne au monde de termes électroniques et électriques. Il contient plus de 30 000 termes et définitions en anglais et en français, ainsi que les termes équivalents dans les langues additionnelles. Egalement appelé Vocabulaire Electrotechnique International (VEI) en ligne.

Service Clients - webstore.iec.ch/csc

Si vous désirez nous donner des commentaires sur cette publication ou si vous avez des questions contactez-nous: csc@iec.ch.

INTERNATIONAL STANDARD

NORME INTERNATIONALE



**Industrial communication networks – Profiles –
Part 5–18: Installation of fieldbuses – Installation profiles for CPF 18**

**Réseaux de communication industriels – Profils –
Partie 5-18: Installation des bus de terrain – Profils d'installation pour CPF 18**

IEC 61784-5-18:2013

<https://standards.iteh.ai/cou/standards/iec/bd/35926-8c62-4c91-b694-ade8337167b2/iec-61784-5-18-2013>

INTERNATIONAL
ELECTROTECHNICAL
COMMISSION

COMMISSION
ELECTROTECHNIQUE
INTERNATIONALE

PRICE CODE
CODE PRIX

U

ICS 25.040.40; 35.100.40

ISBN 978-2-8322-1071-0

**Warning! Make sure that you obtained this publication from an authorized distributor.
Attention! Veuillez vous assurer que vous avez obtenu cette publication via un distributeur agréé.**

CONTENTS

FOREWORD.....	6
INTRODUCTION.....	8
1 Scope.....	9
2 Normative references	9
3 Terms, definitions and abbreviated terms	9
4 CPF 18: Overview of installation profiles	9
5 Installation profile conventions	9
6 Conformance to installation profiles.....	10
Annex A (normative) CP 18/1 and CP 18/2 (SafetyNET p) specific installation profile	11
A.1 Installation profile scope.....	11
A.2 Normative references	11
A.3 Installation profile terms, definitions, and abbreviated terms.....	11
A.3.1 Terms and definitions	11
A.3.2 Abbreviated terms	11
A.3.3 Conventions for installation profiles.....	11
A.4 Installation planning	11
A.4.1 Général.....	11
A.4.1.1 Objective.....	11
A.4.1.2 Cabling in industrial premises.....	11
A.4.1.3 The planning process	11
A.4.1.4 Specific requirements for CPs	11
A.4.1.5 Specific requirements for generic cabling in accordance with ISO/IEC 24702.....	11
A.4.2 Planning requirements.....	11
A.4.2.1 Safety.....	11
A.4.2.2 Security.....	11
A.4.2.3 Environmental considerations and EMC.....	12
A.4.2.4 Specific requirements for generic cabling in accordance with ISO/IEC 24702	12
A.4.3 Network capabilities	12
A.4.3.1 Network topology.....	12
A.4.3.2 Network characteristics	12
A.4.4 Selection and use of cabling components.....	14
A.4.4.1 Cable selection	14
A.4.4.2 Connecting hardware selection	15
A.4.4.3 Connections within a channel/permanent link.....	16
A.4.4.4 Terminators	17
A.4.4.5 Device location and connection.....	17
A.4.4.6 Coding and labelling	17
A.4.4.7 Earthing and bonding of equipment and devices and shielded cabling.....	18
A.4.4.8 Storage and transportation of cables.....	18
A.4.4.9 Routing of cables	19
A.4.4.10 Separation of circuit.....	19
A.4.4.11 Mechanical protection of cabling components	19

A.4.4.12	Installation in special areas	19
A.4.5	Cabling planning documentation	19
A.4.5.1	Common description	19
A.4.5.2	Cabling planning documentation for CPs	19
A.4.5.3	Network certification documentation	19
A.4.5.4	Cabling planning documentation for generic cabling in accordance with ISO/IEC 24702	19
A.4.6	Verification of cabling planning specification	19
A.5	Installation implementation	19
A.5.1	General requirements	19
A.5.1.1	Common description	19
A.5.1.2	Installation of CPs	19
A.5.1.3	Installation of generic cabling in industrial premises	19
A.5.2	Cable installation	20
A.5.2.1	General requirements for all cabling types	20
A.5.2.2	Installation and routing	21
A.5.2.3	Specific requirements for CPs	21
A.5.2.4	Specific requirements for wireless installation	21
A.5.2.5	Specific requirements for generic cabling in accordance with ISO/IEC 24702	21
A.5.3	Connector installation	22
A.5.3.1	Common description	22
A.5.3.2	Shielded connectors	22
A.5.3.3	Unshielded connectors	22
A.5.3.4	Specific requirements for CPs	22
A.5.3.5	Specific requirements for generic cabling in accordance with ISO/IEC 24702	22
A.5.4	Terminator installation	22
A.5.5	Device installation	22
A.5.5.1	Common description	22
A.5.5.2	Specific requirements for CPs	22
A.5.6	Coding and labelling	22
A.5.6.1	Common description	22
A.5.6.2	Specific requirements for CPs	22
A.5.7	Earthing and bonding of equipment and devices and shield cabling	22
A.5.7.1	Common description	22
A.5.7.2	Bonding and earthing of enclosures and pathways	22
A.5.7.3	Earthing methods	22
A.5.7.4	Shield termination methods	22
A.5.7.5	Specific requirements for CPs	23
A.5.7.6	Specific requirements for generic cabling in accordance with ISO/IEC 24702	23
A.5.8	As-implemented cabling documentation	23
A.6	Installation verification and installation acceptance test	23
A.6.1	General	23
A.6.2	Installation verification	23
A.6.2.1	General	23
A.6.2.2	Verification according to cabling planning documentation	23
A.6.2.3	Verification of earthing and bonding	23
A.6.2.4	Verification of shield earthing	23

A.6.2.5	Verification of cabling system.....	23
A.6.2.6	Cable selection verification	23
A.6.2.7	Connector verification	23
A.6.2.8	Connection verification.....	23
A.6.2.9	Terminators verification.....	24
A.6.2.10	Coding and labelling verification	24
A.6.2.11	Verification report	24
A.6.3	Installation acceptance test	24
A.6.3.1	General	24
A.6.3.2	Acceptance test of Ethernet-based cabling	24
A.6.3.3	Acceptance test of non-Ethernet-based cabling	24
A.6.3.4	Specific requirements for wireless installation.....	24
A.6.3.5	Acceptance test report.....	24
A.7	Installation administration.....	25
A.7.1	General	25
A.7.2	Fields covered by the administration	25
A.7.3	Basic principles for the administration system.....	25
A.7.4	Working procedures	25
A.7.5	Device location labelling.....	25
A.7.6	Component cabling labelling.....	25
A.7.7	Documentation	25
A.7.8	Specific requirements for administration.....	25
A.8	Installation maintenance and installation troubleshooting	25
A.8.1	General	25
A.8.2	Maintenance.....	25
A.8.2.1	Scheduled maintenance	25
A.8.2.2	Condition-based maintenance	25
A.8.2.3	Corrective maintenance.....	25
A.8.3	Troubleshooting	25
A.8.3.1	General description	25
A.8.3.2	Evaluation of the problem	25
A.8.3.3	Typical problems	25
A.8.3.4	Troubleshooting procedure	25
A.8.3.5	Simplified troubleshooting procedure.....	25
A.8.4	Specific requirements for maintenance and troubleshooting	25
Bibliography.....		26
Figure 1 – Standards relationships.....		8
Table A.1 – Network characteristics for balanced cabling based on Ethernet		13
Table A.2 – Network characteristics for optical fibre cabling.....		13
Table A.3 – Information relevant to copper cable: fixed cables.....		14
Table A.4 – Information relevant to copper cable: cords.....		14
Table A.5 – Information relevant to optical fibre cables		15
Table A.6 – Connectors for balanced cabling CPs based on Ethernet		15
Table A.7 – Optical fibre connecting hardware		16
Table A.8 – Relationship between FOC and fibre types (CP 18/1 and CP 18/2)		16
Table A.9 – Parameters for balanced cables		20

Table A.10 – Parameters for silica optical fibre cables 20
Table A.11 – Parameters for POF optical fibre cables 20
Table A.12 – Parameters for hard clad silica optical fibre cables 21

Withdrawing

iTech Standards
(<https://standards.iteh.ai>)
Document Preview

<https://standards.iteh.ai/standards/iec/bd/25926-8c62-4c91-b694-ade8337167b2/iec-61784-5-18-2013>

<https://standards.iteh.ai/standards/iec/bd/25926-8c62-4c91-b694-ade8337167b2/iec-61784-5-18-2013>

INTERNATIONAL ELECTROTECHNICAL COMMISSION

**INDUSTRIAL COMMUNICATION NETWORKS –
PROFILES –**

**Part 5–18: Installation of fieldbuses –
Installation profiles for CPF 18**

FOREWORD

- 1) The International Electrotechnical Commission (IEC) is a worldwide organization for standardization comprising all national electrotechnical committees (IEC National Committees). The object of IEC is to promote international co-operation on all questions concerning standardization in the electrical and electronic fields. To this end and in addition to other activities, IEC publishes International Standards, Technical Specifications, Technical Reports, Publicly Available Specifications (PAS) and Guides (hereafter referred to as “IEC Publication(s)”). Their preparation is entrusted to technical committees; any IEC National Committee interested in the subject dealt with may participate in this preparatory work. International, governmental and non-governmental organizations liaising with the IEC also participate in this preparation. IEC collaborates closely with the International Organization for Standardization (ISO) in accordance with conditions determined by agreement between the two organizations.
- 2) The formal decisions or agreements of IEC on technical matters express, as nearly as possible, an international consensus of opinion on the relevant subjects since each technical committee has representation from all interested IEC National Committees.
- 3) IEC Publications have the form of recommendations for international use and are accepted by IEC National Committees in that sense. While all reasonable efforts are made to ensure that the technical content of IEC Publications is accurate, IEC cannot be held responsible for the way in which they are used or for any misinterpretation by any end user.
- 4) In order to promote international uniformity, IEC National Committees undertake to apply IEC Publications transparently to the maximum extent possible in their national and regional publications. Any divergence between any IEC Publication and the corresponding national or regional publication shall be clearly indicated in the latter.
- 5) IEC itself does not provide any attestation of conformity. Independent certification bodies provide conformity assessment services and, in some areas, access to IEC marks of conformity. IEC is not responsible for any services carried out by independent certification bodies.
- 6) All users should ensure that they have the latest edition of this publication.
- 7) No liability shall attach to IEC or its directors, employees, servants or agents including individual experts and members of its technical committees and IEC National Committees for any personal injury, property damage or other damage of any nature whatsoever, whether direct or indirect, or for costs (including legal fees) and expenses arising out of the publication, use of, or reliance upon, this IEC Publication or any other IEC Publications.
- 8) Attention is drawn to the Normative references cited in this publication. Use of the referenced publications is indispensable for the correct application of this publication.
- 9) Attention is drawn to the possibility that some of the elements of this IEC Publication may be the subject of patent rights. IEC shall not be held responsible for identifying any or all such patent rights.

International Standard IEC 61784-5-18 has been prepared by subcommittee 65C: Industrial networks, of IEC technical committee 65: Industrial-process measurement, control and automation.

This standard is to be used in conjunction with IEC 61918:2013.

The text of this standard is based on the following documents:

FDIS	Report on voting
65C/738/FDIS	65C/743/RVD

Full information on the voting for the approval of this standard can be found in the report on voting indicated in the above table.

This publication has been drafted in accordance with the ISO/IEC Directives, Part 2.

A list of all parts of the IEC 61784-5 series, published under the general title *Industrial communication networks – Profiles – Installation of fieldbuses*, can be found on the IEC website.

The committee has decided that the contents of this publication will remain unchanged until the maintenance result date indicated on the IEC web site under "<http://webstore.iec.ch>" in the data related to the specific publication. At this date, the publication will be

- reconfirmed,
- withdrawn,
- replaced by a revised edition, or
- amended.

IMPORTANT – The 'colour inside' logo on the cover page of this publication indicates that it contains colours which are considered to be useful for the correct understanding of its contents. Users should therefore print this document using a colour printer.

iTech Standards
(<https://standards.itih.ai>)
Document Preview

[IEC 61784-5-18:2013](https://standards.itih.ai/standards/iec/bd325926-8c62-4c91-b694-ade8337167b2/iec-61784-5-18-2013)

<https://standards.itih.ai/standards/iec/bd325926-8c62-4c91-b694-ade8337167b2/iec-61784-5-18-2013>

INTRODUCTION

This International Standard is one of a series produced to facilitate the use of communication networks in industrial control systems.

IEC 61918:2013 provides the common requirements for the installation of communication networks in industrial control systems. This installation profile standard provides the installation profiles of the communication profiles (CP) of a specific communication profile family (CPF) by stating which requirements of IEC 61918 fully apply and, where necessary, by supplementing, modifying, or replacing the other requirements (see Figure 1).

For general background on fieldbuses, their profiles, and relationship between the installation profiles specified in this standard, see IEC 61158-1.

Each CP installation profile is specified in a separate annex of this standard. Each annex is structured exactly as the reference standard IEC 61918 for the benefit of the persons representing the roles in the fieldbus installation process as defined in IEC 61918 (planner, installer, verification personnel, validation personnel, maintenance personnel, administration personnel). By reading the installation profile in conjunction with IEC 61918, these persons immediately know which requirements are common for the installation of all CPs and which are modified or replaced. The conventions used to draft this standard are defined in Clause 5.

The provision of the installation profiles in one standard for each CPF (for example IEC 61784-5-18 for CPF 18), allows readers to work with standards of a convenient size.

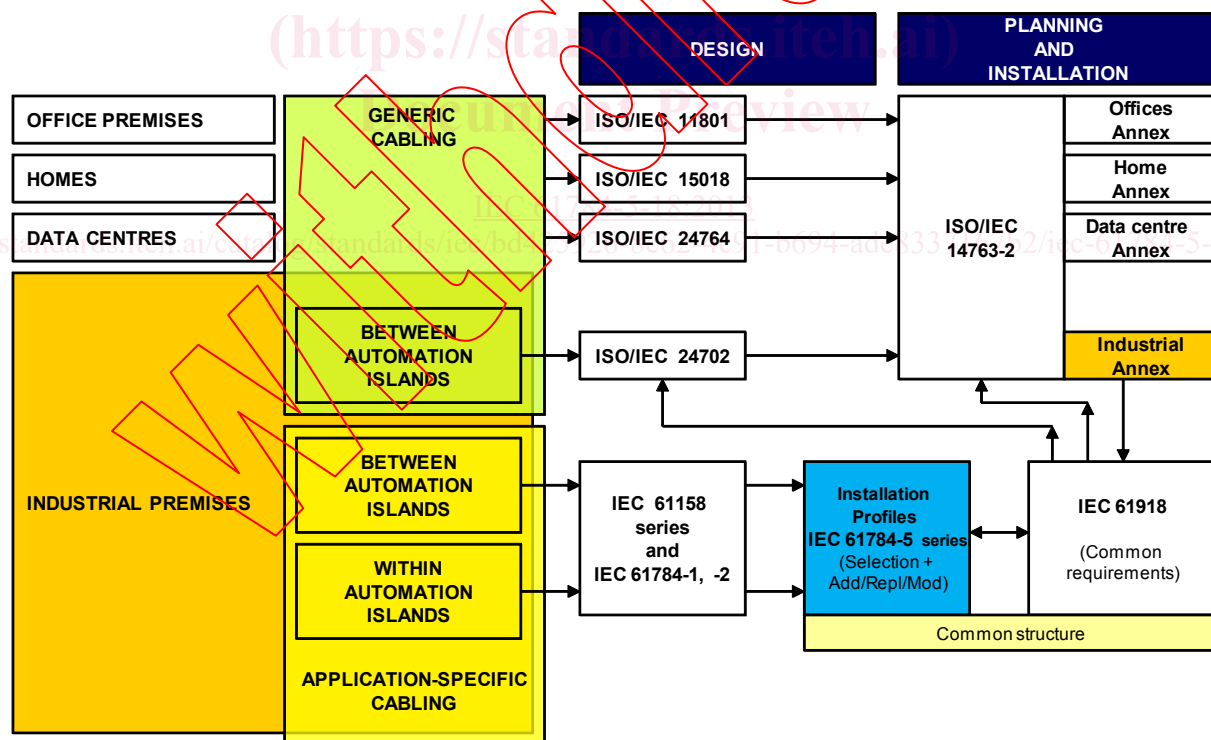

Figure 1 – Standards relationships

INDUSTRIAL COMMUNICATION NETWORKS – PROFILES –

Part 5–18: Installation of fieldbuses – Installation profiles for CPF 18

1 Scope

This part of IEC 61784-5 specifies the installation profiles for CPF 18 (SafetyNET p¹).

The installation profiles are specified in the annex. This annex is read in conjunction with IEC 61918:2013.

2 Normative references

The following documents, in whole or in part, are normatively referenced in this document and are indispensable for its application. For dated references, only the edition cited applies. For undated references, the latest edition of the referenced document (including any amendments) applies.

IEC 61918:2013, *Industrial communication networks – Installation of communication networks in industrial premises*

The normative references of IEC 61918:2013, Clause 2, apply.

3 Terms, definitions and abbreviated terms

For the purpose of this document, the terms, definitions and abbreviated terms given in IEC 61918:2013 Clause 3, apply.

4 CPF 18: Overview of installation profiles

CPF 18 consists of two Communication Profiles as specified in IEC 61784-2.

The installation requirements for CP 18/1 (SafetyNET p RTFL) and CP 18/2 (SafetyNET p RTFN) are specified in Annex A.

5 Installation profile conventions

The numbering of the clauses and subclauses in the annexes of this standard corresponds to the numbering of IEC 61918 main clauses and subclauses.

The annex clauses and subclauses of this standard supplement, modify, or replace the respective clauses and subclauses in IEC 61918.

¹ SafetyNET p is trade name of Pilz GmbH & Co. KG. This information is given for the convenience of users of this document and does not constitute an endorsement by IEC of the trade name holder or any of its products. Compliance does not require use of the trade name SafetyNET p. Use of the trade name SafetyNET p requires permission of the trade name holder.

Where there is no corresponding subclause of IEC 61918 in the normative annexes in this standard, the subclause of IEC 61918 applies without modification.

The annex heading letter represents the installation profile assigned in Clause 4. The annex heading number shall represent the corresponding numbering of IEC 61918.

EXAMPLE "Subclause A.4.4" in IEC 61784-5-18 means that CP 18/1 and CP 18/2 specify the subclause 4.4 of IEC 61918.

All main clauses of IEC 61918 are cited and apply in full unless otherwise stated in each normative installation profile annex.

If all subclauses of a (sub)clause are omitted, then the corresponding IEC 61918 (sub)clause applies.

If in a (sub)clause it is written "Not applicable.", then the corresponding IEC 61918 (sub)clause does not apply.

If in a (sub)clause it is written "*Addition:*", then the corresponding IEC 61918 (sub)clause applies with the additions written in the profile.

If in a (sub)clause it is written "*Replacement:*", then the text provided in the profile replaces the text of the corresponding IEC 61918 (sub)clause.

NOTE A replacement can also comprise additions.

If in a (sub)clause it is written "*Modification:*", then the corresponding IEC 61918 (sub)clause applies with the modifications written in the profile.

If all (sub)clauses of a (sub)clause are omitted but in this (sub)clause it is written "*(Sub)clause x has addition:*" (or "*replacement:*") or "*(Sub)clause x is not applicable.*", then (sub)clause x becomes valid as declared and all the other corresponding IEC 61918 (sub)clauses apply.

6 Conformance to installation profiles

Each installation profile within this standard includes part of IEC 61918:2013. It may also include defined additional specifications.

A statement of compliance to an installation profile of this standard shall be stated² as either

Compliance to IEC 61784-5-18:2013³ for CP 18/m <name> or

Compliance to IEC 61784-5-18 (Ed.1.0) for CP 18/m <name>

where the name within the angle brackets < > is optional and the angle brackets are not to be included. The m within CP 18/m shall be replaced by the profile number 1 to 2.

NOTE The name can be the name of the profile, for example SafetyNET p.

If the name is a trade name then the permission of the trade name holder shall be required.

Product standards shall not include any conformity assessment aspects (including quality management provisions), neither normative nor informative, other than provisions for product testing (evaluation and examination).

² In accordance with ISO/IEC Directives.

³ The date should not be used when the edition number is used.

Annex A (normative)

CP 18/1 and CP 18/2 (SafetyNET p) specific installation profile

A.1 Installation profile scope

Addition:

This standard specifies the installation profile for Communication Profile CP 18/1 and CP 18/2 (SafetyNET p). The CP 18/1 and CP 18/2 are specified in IEC 61784-2.

A.2 Normative references

A.3 Installation profile terms, definitions, and abbreviated terms

A.3.1 Terms and definitions

A.3.2 Abbreviated terms

A.3.3 Conventions for installation profiles

Not applicable.

A.4 Installation planning

A.4.1 General

A.4.1.1 Objective

A.4.1.2 Cabling in industrial premises

A.4.1.3 The planning process

A.4.1.4 Specific requirements for CPs

Not applicable.

A.4.1.5 Specific requirements for generic cabling in accordance with ISO/IEC 24702

A.4.2 Planning requirements

A.4.2.1 Safety

A.4.2.1.1 General

A.4.2.1.2 Electric safety

A.4.2.1.3 Functional safety

A.4.2.1.4 Intrinsic safety

Not applicable.

A.4.2.1.5 Safety of optical fibre communication systems

A.4.2.2 Security

A.4.2.3 Environmental considerations and EMC

A.4.2.3.1 Description methodology

A.4.2.3.2 Use of the described environment to produce a bill of material

A.4.2.4 Specific requirements for generic cabling in accordance with ISO/IEC 24702

A.4.3 Network capabilities

A.4.3.1 Network topology

A.4.3.1.1 Common description

A.4.3.1.2 Basic physical topologies for passive networks

Not applicable.

A.4.3.1.3 Basic physical topologies for active networks

Addition:

Ring topology shall be used when cable redundancy is required.

A.4.3.1.4 Combination of basic topologies

A.4.3.1.5 Specific requirements for CPs

Not applicable.

A.4.3.1.6 Specific requirements for generic cabling in accordance with ISO/IEC 24702

A.4.3.2 Network characteristics

A.4.3.2.1 General

A.4.3.2.2 Network characteristics for balanced cabling not based on Ethernet

Not applicable.

A.4.3.2.3 Network characteristics for balanced cabling based on Ethernet

Replacement:

Table A.1 provides values based on the template given in IEC 61918:2013, Table 2.