



SLOVENSKI STANDARD

SIST EN 61230:2009

01-januar-2009

Nadomešča:

SIST EN 61230:2000

SIST EN 61230:2000/A11:2000

Delo pod napetostjo - Prenosna oprema za ozemljitev ali ozemljitev in kratkostičenje (IEC 61230:2008)

Live working - Portable equipment for earthing or earthing and short-circuiting

Arbeiten unter Spannung - Ortsveränderliche Geräte zum Erden oder Erden und Kurzschließen

Travaux sous tension - Equipements portables de mise à la terre ou de mise à la terre et en court-circuit

Ta slovenski standard je istoveten z: EN 61230:2008

ICS:

13.260	Varstvo pred električnim udarom. Delo pod napetostjo	Protection against electric shock. Live working
29.260.01	Električna oprema za delo v posebnih razmerah na splošno	Electrical equipment for working in special conditions in general

SIST EN 61230:2009

en,fr,de

iTeh STANDARD PREVIEW
(standards.iteh.ai)

SIST EN 61230:2009

<https://standards.iteh.ai/catalog/standards/sist/3a337f26-f4e1-4b62-b6d9-2d7251d08a28/sist-en-61230-2009>

EUROPEAN STANDARD
NORME EUROPÉENNE
EUROPÄISCHE NORM

EN 61230

November 2008

ICS 13.260; 29.240.20; 29.260.99

Supersedes EN 61230:1995 + A11:1999

English version

**Live working -
Portable equipment for earthing or earthing and short-circuiting
(IEC 61230:2008)**

Travaux sous tension -
Equipements portables de mise à la terre
ou de mise à la terre et en court-circuit
(CEI 61230:2008)

Arbeiten unter Spannung -
Ortsveränderliche Geräte zum Erden
oder Erden und Kurzschließen
(IEC 61230:2008)

This European Standard was approved by CENELEC on 2008-10-01. CENELEC members are bound to comply with the CEN/CENELEC Internal Regulations which stipulate the conditions for giving this European Standard the status of a national standard without any alteration.

Up-to-date lists and bibliographical references concerning such national standards may be obtained on application to the Central Secretariat or to any CENELEC member.

This European Standard exists in three official versions (English, French, German). A version in any other language made by translation under the responsibility of a CENELEC member into its own language and notified to the Central Secretariat has the same status as the official versions.

CENELEC members are the national electrotechnical committees of Austria, Belgium, Bulgaria, Cyprus, the Czech Republic, Denmark, Estonia, Finland, France, Germany, Greece, Hungary, Iceland, Ireland, Italy, Latvia, Lithuania, Luxembourg, Malta, the Netherlands, Norway, Poland, Portugal, Romania, Slovakia, Slovenia, Spain, Sweden, Switzerland and the United Kingdom.

CENELEC

European Committee for Electrotechnical Standardization
Comité Européen de Normalisation Electrotechnique
Europäisches Komitee für Elektrotechnische Normung

Central Secretariat: rue de Stassart 35, B - 1050 Brussels

Foreword

The text of document 78/741/FDIS, future edition 2 of IEC 61230, prepared by IEC TC 78, Live working, was submitted to the IEC-CENELEC parallel vote and was approved by CENELEC as EN 61230 on 2008-10-01.

This European Standard supersedes EN 61230:1995 + A11:1999.

The major changes are:

- extension of the scope to cover the use of equipment on d.c. installations;
- extension of the use of aluminium to all conductive parts of the device;
- extension of the application to silicone rubber cables made by the revision of TC 20 document EN 61138;
- possibility of using this standard for separate components of the equipment;
- general revision of requirements and tests;
- deletion of the marking requirement of the double triangle to clarify that the products covered by the standard are not appropriate for performing live working;
- clarification and modification to the procedure for short-circuit test:
 - change of the number of devices submitted to test,
 - change of the pre-conditioning time to 48 h,
 - clarification of the test procedure for separate components.
- application of conformity assessment for products having completed the production phase, according to EN 61318:2008;
- revision of existing annexes;
- change of normative Annexes A and C into informative Annexes C and B with a reviewed wording;
- deletion of Annex B, not applicable according to EN 61318:2008;
- deletion of Annex D, its requirements and tests being now included in the body of the standard;
- introduction of a new informative Annex A on railway application;
- introduction of a new informative Annex D giving guidelines for determination of the equivalent r.m.s. value of a short-circuit current;
- revision of the list of type tests, which now appears in normative Annex E;
- introduction of a new normative Annex F on classification of defects.

The following dates were fixed:

- | | | |
|--|-------|------------|
| – latest date by which the EN has to be implemented at national level by publication of an identical national standard or by endorsement | (dop) | 2009-07-01 |
| – latest date by which the national standards conflicting with the EN have to be withdrawn | (dow) | 2011-10-01 |

Annex ZA has been added by CENELEC.

Endorsement notice

The text of the International Standard IEC 61230:2008 was approved by CENELEC as a European Standard without any modification.

In the official version, for Bibliography, the following notes have to be added for the standards indicated:

IEC 60071-1	NOTE Harmonized as EN 60071-1:2006 (not modified).
IEC 60071-2	NOTE Harmonized as EN 60071-2:1997 (not modified).
IEC 60228	NOTE Harmonized as EN 60228:2005 (not modified).
IEC 60743 + A1	NOTE Harmonized as EN 60743:2001 + A1:2008 (not modified).
IEC 60832	NOTE Harmonized as EN 60832:1996 (modified).
IEC 60855	NOTE Harmonized as EN 60855:1996 (modified).
IEC 60865-1	NOTE Harmonized as EN 60865-1:1993 (not modified).
IEC 60909-0	NOTE Harmonized as EN 60909-0:2001 (not modified).
IEC 61235	NOTE Harmonized as EN 61235:1995 (modified).
IEC 61472	NOTE Harmonized as EN 61472:2004 (not modified).
ISO 9000	NOTE Harmonized as EN ISO 9000:2005 (not modified).

iTeh STANDARD PREVIEW
(standards.iteh.ai)

[SIST EN 61230:2009](#)

<https://standards.iteh.ai/catalog/standards/sist/3a337f26-f4e1-4b62-b6d9-2d7251d08a28/sist-en-61230-2009>

Annex ZA (normative)

Normative references to international publications with their corresponding European publications

The following referenced documents are indispensable for the application of this document. For dated references, only the edition cited applies. For undated references, the latest edition of the referenced document (including any amendments) applies.

NOTE When an international publication has been modified by common modifications, indicated by (mod), the relevant EN/HD applies.

<u>Publication</u>	<u>Year</u>	<u>Title</u>	<u>EN/HD</u>	<u>Year</u>
IEC 60060-1	1989	High-voltage test techniques - Part 1: General definitions and test requirements	HD 588.1 S1	1991
IEC 60068-2-11	1981	Environmental testing - Part 2: Tests - Test Ka: Salt mist	EN 60068-2-11	1999
IEC 60068-2-42	2003	Environmental testing - Part 2-42: Tests - Test Kc: Sulphur dioxide test for contacts and connections	EN 60068-2-42	2003
IEC 60811-1-4 + corr. May + A1 A2	1985 1986 1993 2001	Common test methods for insulating and sheathing materials of electric cables - Part 1: Methods for general application - Section 4: Tests at low temperature	EN 60811-1-4 A2	1995 2001
IEC 60811-2-1 A1	1998 2001	Insulating and sheathing materials of electric and optical cables - Common test methods - Part 2-1: Methods specific to elastomeric compounds - Ozone resistance, hot set and mineral oil immersion tests	EN 60811-2-1 A1	1998 2001
IEC 60811-3-1 A1 A2	1985 1994 2001	Common test methods for insulating and sheathing materials of electric cables - Part 3: Methods specific to PVC compounds - Section 1: Pressure test at high temperature - Tests for resistance to cracking	EN 60811-3-1 A1 A2	1995 1996 2001
IEC 61138 (mod)	2007	Cables for portable earthing and short-circuiting equipment	EN 61138	2007
IEC 61318	2007	Live working - Conformity assessment applicable to tools, devices and equipment	EN 61318	2008
IEC 61477 A1 A2 (mod)	2001 2002 2004	Live working - Minimum requirements for the utilization of tools, devices and equipment	EN 61477 A1 A2	2002 2002 2005



IEC 61230

Edition 2.0 2008-07

INTERNATIONAL STANDARD

NORME INTERNATIONALE

Live working – Portable equipment for earthing or earthing and short-circuiting

Travaux sous tension – Equipements portables de mise à la terre ou de mise à la terre et en court-circuit

[SIST EN 61230:2009](https://standards.iteh.ai/catalog/standards/sist/3a337f26-f4e1-4b62-b6d9-2d7251d08a28/sist-en-61230-2009)

<https://standards.iteh.ai/catalog/standards/sist/3a337f26-f4e1-4b62-b6d9-2d7251d08a28/sist-en-61230-2009>

INTERNATIONAL
ELECTROTECHNICAL
COMMISSION

COMMISSION
ELECTROTECHNIQUE
INTERNATIONALE

PRICE CODE
CODE PRIX

XB

ICS 13.260; 29.240.20; 29.260.99

ISBN 2-8318-9875-7

CONTENTS

FOREWORD.....	5
INTRODUCTION.....	7
1 Scope.....	8
2 Normative references.....	12
3 Terms and definitions.....	13
4 Requirements.....	17
4.1 General.....	17
4.2 Electrical rating.....	18
4.3 Cables for earthing and short-circuiting.....	18
4.3.1 Selection of cables.....	18
4.3.2 Earthing cables used on solidly earthed (neutral) systems.....	19
4.3.3 Earthing cables used on non-solidly earthed (neutral) systems.....	19
4.4 Short-circuiting bars.....	19
4.5 Connections of cables to rigid parts within devices.....	20
4.6 Clamps.....	20
4.7 Earthing and short-circuiting device.....	20
4.8 Basic safety requirements for the insulating element(s) of the insulating component.....	21
4.9 Marking.....	21
4.9.1 General.....	21
4.9.2 Marking on earthing and short-circuiting device.....	21
4.9.3 Marking on clamp.....	22
4.9.4 Marking on cable.....	22
4.9.5 Marking on other components.....	22
4.10 Instructions for use.....	22
5 Tests.....	23
5.1 General.....	23
5.2 Verification and checking.....	23
5.3 Tests for the selection of cables.....	24
5.3.1 Cables complying with IEC 61138.....	24
5.3.2 Cables not complying with IEC 61138.....	24
5.4 Fatigue and humidity penetration tests on cable with end fittings.....	24
5.4.1 Fatigue test.....	24
5.4.2 Humidity penetration test.....	26
5.5 Tension test on cable with end fittings.....	26
5.6 Test on clamps, permanent connection points and connections.....	27
5.6.1 Tests for tightening types.....	27
5.6.2 Tests for non-tightening types.....	27
5.7 Short-circuit current test.....	27
5.7.1 General.....	27
5.7.2 Preparation of test pieces.....	29
5.7.3 Test set-ups and test arrangements.....	33
5.7.4 Test current, Joule-integral and duration.....	34
5.7.5 Documentation and evaluation of the test.....	35
5.7.6 Alternative means to short-circuit current test for conformity assessment during production phase.....	36

5.8 Durability of marking	36
6 Conformity assessment	36
7 Modifications	36
Annex A (informative) Guidelines for portable equipment for earthing to be used on railway systems	37
Annex B (informative) Guidelines for earthing sticks	41
Annex C (informative) Guidelines for selection, use and maintenance of portable earthing or earthing and short-circuiting equipment.....	45
Annex D (informative) Guideline for determination of the equivalent r.m.s. value of a short-time current during a short-circuit of a given duration.....	56
Annex E (normative) List of type tests.....	58
Annex F (normative) Classification of defects	59
Bibliography.....	60
Figure 1 – Examples of portable equipment and device for installations, network and railway systems application.....	9
Figure 2 – Connection diagrams of single and multi-phase earthing and short-circuiting devices for network application	11
Figure 3 – Illustration of a three-phase earthing and short-circuiting device with short-circuiting bar and earthing cable(s) for installation and network application.....	12
Figure 4 – Apparatus for fatigue testing with bending and twisting	25
Figure 5 – Examples of multiple combinations of clamps accommodating different shapes and sizes of connection points	29
Figure 6 – Test set-ups for testing multi-phase devices connected between rigid conductors for substations	31
Figure 7 – Test set-ups for testing multi-phase short-circuiting devices for overhead lines.....	32
Figure 8 – Test set-ups for testing single-phase devices for overhead lines and for open air substations.....	33
Figure 9 – Shape of the short-circuit current during test.....	35
Figure A.1 – Test set-up for testing single phase equipment for railway systems	39
Figure B.1 – Arrangement for bending tests on earthing sticks of circular cross-section.....	43
Figure B.2 – Arrangement for torsion tests on earthing sticks of circular cross-section.....	44
Figure C.1 – Curves representing the temperature heating of different nature of conductors related to the value of the Joule-integral J^2_t	49
Figure C.2 – Determination of conductor temperature from heating.....	50
Figure C.3 – Determination of J^2_t	51
Figure C.4 – Example of the usable region for a device	53
Figure D.1 – Determination of short-time current.....	57
Table 1 – Usual lengths of earthing and short-circuiting cables for different types of installations and different voltage levels.....	11
Table 2 – Minimum cross-section of earthing cables related to the cross-section of the short-circuiting cables and/or bars on non-solidly earthed (neutral) systems	19
Table 3 – Tension test force on cable with end fittings	27
Table A.1 – Short circuit values for copper cable with a maximum temperature of 450 °C	40

Table B.1 – Maximum deflection	43
Table C.1 – Comparison of different standard values of nominal cross-sections.....	47
Table C.2 – Short-circuit close to generator – Short-circuit current values in kA for copper cables with a maximum temperature of 300°C	48
Table E.1 – List of type tests referred to subclauses	58
Table F.1 – Classification of defects and associated requirements and tests	59

iTeh STANDARD PREVIEW
(standards.iteh.ai)

[SIST EN 61230:2009](#)

<https://standards.iteh.ai/catalog/standards/sist/3a337f26-f4e1-4b62-b6d9-2d7251d08a28/sist-en-61230-2009>

INTERNATIONAL ELECTROTECHNICAL COMMISSION

**LIVE WORKING –
PORTABLE EQUIPMENT FOR EARTHING OR
EARTHING AND SHORT-CIRCUITING****FOREWORD**

- 1) The International Electrotechnical Commission (IEC) is a worldwide organization for standardization comprising all national electrotechnical committees (IEC National Committees). The object of IEC is to promote international co-operation on all questions concerning standardization in the electrical and electronic fields. To this end and in addition to other activities, IEC publishes International Standards, Technical Specifications, Technical Reports, Publicly Available Specifications (PAS) and Guides (hereafter referred to as "IEC Publication(s)"). Their preparation is entrusted to technical committees; any IEC National Committee interested in the subject dealt with may participate in this preparatory work. International, governmental and non-governmental organizations liaising with the IEC also participate in this preparation. IEC collaborates closely with the International Organization for Standardization (ISO) in accordance with conditions determined by agreement between the two organizations.
- 2) The formal decisions or agreements of IEC on technical matters express, as nearly as possible, an international consensus of opinion on the relevant subjects since each technical committee has representation from all interested IEC National Committees.
- 3) IEC Publications have the form of recommendations for international use and are accepted by IEC National Committees in that sense. While all reasonable efforts are made to ensure that the technical content of IEC Publications is accurate, IEC cannot be held responsible for the way in which they are used or for any misinterpretation by any end user.
- 4) In order to promote international uniformity, IEC National Committees undertake to apply IEC Publications transparently to the maximum extent possible in their national and regional publications. Any divergence between any IEC Publication and the corresponding national or regional publication shall be clearly indicated in the latter.
- 5) IEC provides no marking procedure to indicate its approval and cannot be rendered responsible for any equipment declared to be in conformity with an IEC Publication.
- 6) All users should ensure that they have the latest edition of this publication.
- 7) No liability shall attach to IEC or its directors, employees, servants or agents including individual experts and members of its technical committees and IEC National Committees for any personal injury, property damage or other damage of any nature whatsoever, whether direct or indirect, or for costs (including legal fees) and expenses arising out of the publication, use of, or reliance upon, this IEC Publication or any other IEC Publications.
- 8) Attention is drawn to the Normative references cited in this publication. Use of the referenced publications is indispensable for the correct application of this publication.
- 9) Attention is drawn to the possibility that some of the elements of this IEC Publication may be the subject of patent rights. IEC shall not be held responsible for identifying any or all such patent rights.

International Standard IEC 61230 has been prepared by IEC technical committee 78: Live working.

This second edition cancels and replaces the first edition published in 1993. It constitutes a technical revision.

The major changes are:

- extension of the scope to cover the use of equipment on d.c. installations;
- extension of the use of aluminium to all conductive parts of the device;
- extension of the application to silicone rubber cables made by the revision of TC 20 document IEC 61138;
- possibility of using this standard for separate components of the equipment;
- general revision of requirements and tests;
- deletion of the marking requirement of the double triangle to clarify that the products covered by the standard are not appropriate for performing live working;

- clarification and modification to the procedure for short-circuit test:
 - change of the number of devices submitted to test,
 - change of the pre-conditioning time to 48 h,
 - clarification of the test procedure for separate components,
- application of conformity assessment for products having completed the production phase, according to IEC 61318 Ed.3;
- revision of existing annexes;
- change of normative Annexes A and C into informative Annexes C and B with a reviewed wording;
- deletion of Annex B, not applicable according to IEC 61318 Ed.3;
- deletion of Annex D, its requirements and tests being now included in the body of the standard;
- introduction of a new informative Annex A on railway application;
- introduction of a new informative Annex D giving guidelines for determination of the equivalent r.m.s. value of a short-circuit current;
- revision of the list of type tests, which now appears in normative Annex E;
- introduction of a new normative Annex F on classification of defects.

The text of this standard is based on the following documents:

FDIS	Report on voting
78/741/FDIS	78/748/RVD

Full information on the voting for the approval of this standard can be found in the report on voting indicated in the above table.

This publication has been drafted in accordance with the ISO/IEC Directives, Part 2.

The committee has decided that the contents of this publication will remain unchanged until the maintenance result date indicated on the IEC web site under "http://webstore.iec.ch" in the data related to the specific publication. At this date, the publication will be

- reconfirmed,
- withdrawn,
- replaced by a revised edition, or
- amended.

INTRODUCTION

This International Standard has been prepared in accordance with the requirements of IEC 61477.

An agreement may be made between manufacturer and customer for additional requirements, and tests. These additional requirements are prescribed in the customer's specification on the basis of an acceptance procedure.

iTeh STANDARD PREVIEW (standards.iteh.ai)

[SIST EN 61230:2009](https://standards.iteh.ai/catalog/standards/sist/3a337f26-f4e1-4b62-b6d9-2d7251d08a28/sist-en-61230-2009)

<https://standards.iteh.ai/catalog/standards/sist/3a337f26-f4e1-4b62-b6d9-2d7251d08a28/sist-en-61230-2009>

LIVE WORKING – PORTABLE EQUIPMENT FOR EARTHING OR EARTHING AND SHORT-CIRCUITING

1 Scope

This International Standard is applicable to portable equipment, with or without matching connection points, for temporary earthing or earthing and short-circuiting of electrically isolated or de-energized a.c. and d.c. installations, distribution and transmission networks, whether they are overhead or underground or of low or high voltage.

NOTE Annex A provides guidance for application to railway systems.

This standard covers equipment comprising an earthing or a short-circuiting or an earthing and short-circuiting device and insulating component. An example is given in Figure 1a and Figure 1b.

It also covers:

- earthing or short-circuiting or earthing and short-circuiting devices intended to be installed with insulating means. An example of an earthing device is given in Figure 1c;
- separate components, such as conductive extension (see Figure 1b) or clamp or cable with end fittings.

The performance of equipment, devices and components covered by this standard is based on electro-dynamic and electro-thermal effects acting during short-circuit. The withstand capability of the devices and equipment is expressed by their rated values of current, time and peak factor. No rated voltage is given, but the geometrical dimensions of the equipment are also linked to the voltage of the installation.

Examples of connection diagrams of earthing and short-circuiting devices are given in Figures 2 and 3. Associated usual lengths of cables are given in Table 1.

Not covered in this standard are:

- insulating means, such as insulating sticks, telescopic sticks, insulating handles, insulating gloves, aerial devices with insulating booms, insulating ropes to be used to install the earthing and short-circuiting device;
 - insulating components, except for basic safety requirements for the insulating element;
- NOTE Basic safety recommendations for earthing sticks are given in Annex B.
- devices meant only for the draining of induced currents;
 - relevant working procedures for using portable equipment for earthing or earthing and short-circuiting.

NOTE The equipment complying with this standard should be used according to safe working procedures and according to local or national regulation, such as live working or dead working procedures.

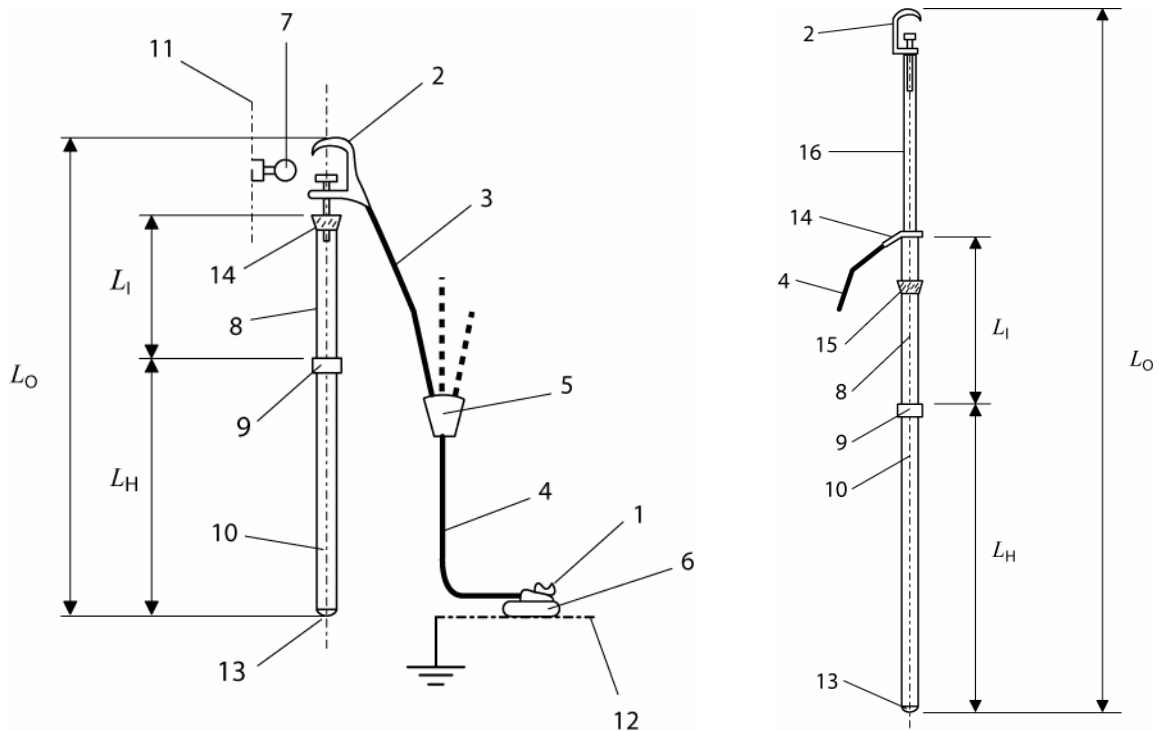
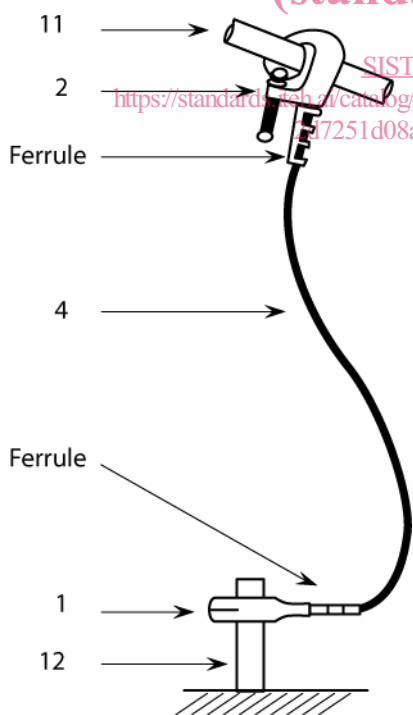

Figure 1a – Multi-phase equipment

Figure 1b – Single-phase equipment with extension



NOTE The same device can also be used for short-circuiting.

Figure 1c – Earthing device

Key

- 1 Earth clamp or rail clamp
- 2 Line clamp or contact line clamp
- 3 Short-circuiting cable(s)
- 4 Earthing cable(s)
- 5 Connecting cluster
- 6 Earth permanent connection point or rail
- 7 Line permanent connection point or overhead contact line profile
- 8 Insulating element
- 9 Handle limit mark
- 10 Handle of earthing stick
- 11 Installation conductor or bar
- 12 Earthing system
- 13 End cap of stick
- 14 End fitting, permanent or detachable
- 15 Stick coupling, detachable for transport reasons
- 16 Conductive extension
- L_1 Length of insulating element
- L_H Length of handle
- L_O Overall length of earthing stick and conductive extension component

NOTE 1 The earthing and short-circuiting device comprises components 1, 2, 3, 4, 5 and 16.

NOTE 2 The earthing stick comprises components 8, 9, 10, 13, 14 and 15.

NOTE 3 The earthing device comprises components 1, 2 and 4.

Figure 1 – Examples of portable equipment and device for installations, network and railway systems application