



SLOVENSKI STANDARD
SIST EN ISO 8493:2004

01-november-2004

BUXca Yý U
SIST EN 10234:1998

Kovinski materiali – Cev - Preskus širjenja cevi (ISO 8493:1998)

Metallic materials - Tube - Drift-expanding test (ISO 8493:1998)

Metallische Werkstoffe - Rohr - Aufweitversuch (ISO 8493:1998)

Matériaux métalliques - Tubes - Essai d'évasement (ISO 8493:1998)

iTeh STANDARD PREVIEW
(standards.iteh.ai)

Ta slovenski standard je istoveten z: EN ISO 8493:2004

<https://standards.iteh.ai/catalog/standards/sist/46d4994f-fa6f-4cb9-8ada-43e8f766f146/sist-en-iso-8493-2004>

ICS:

77.040.10 Mehansko preskušanje kovin Mechanical testing of metals

SIST EN ISO 8493:2004

en

iTeh STANDARD PREVIEW
(standards.iteh.ai)

[SIST EN ISO 8493:2004](#)

<https://standards.iteh.ai/catalog/standards/sist/46d4994f-fa6f-4cb9-8ada-43e8f766f146/sist-en-iso-8493-2004>

EUROPEAN STANDARD
NORME EUROPÉENNE
EUROPÄISCHE NORM

EN ISO 8493

July 2004

ICS 77.040.10

Supersedes EN 10234:1993

English version

Metallic materials - Tube - Drift-expanding test (ISO 8493:1998)

Matériaux métalliques - Tubes - Essai d'évasement (ISO 8493:1998)

Metallische Werkstoffe - Rohr - Aufweitversuch (ISO 8493:1998)

This European Standard was approved by CEN on 1 July 2004.

CEN members are bound to comply with the CEN/CENELEC Internal Regulations which stipulate the conditions for giving this European Standard the status of a national standard without any alteration. Up-to-date lists and bibliographical references concerning such national standards may be obtained on application to the Central Secretariat or to any CEN member.

This European Standard exists in three official versions (English, French, German). A version in any other language made by translation under the responsibility of a CEN member into its own language and notified to the Central Secretariat has the same status as the official versions.

CEN members are the national standards bodies of Austria, Belgium, Cyprus, Czech Republic, Denmark, Estonia, Finland, France, Germany, Greece, Hungary, Iceland, Ireland, Italy, Latvia, Lithuania, Luxembourg, Malta, Netherlands, Norway, Poland, Portugal, Slovakia, Slovenia, Spain, Sweden, Switzerland and United Kingdom.

ITh STANDARD PREVIEW
(standards.iteh.ai)
SIST EN ISO 8493:2004
<https://standards.iteh.ai/catalog/standards/sist/46d4994f-fa6f-4cb9-8ada-43e8f766f146/sist-en-iso-8493-2004>



EUROPEAN COMMITTEE FOR STANDARDIZATION
COMITÉ EUROPÉEN DE NORMALISATION
EUROPÄISCHES KOMITEE FÜR NORMUNG

Management Centre: rue de Stassart, 36 B-1050 Brussels

EN ISO 8493:2004 (E)**Foreword**

The text of ISO 8493:1998 has been prepared by Technical Committee ISO/TC 164 "Mechanical testing of metals" of the International Organization for Standardization (ISO) and has been taken over as EN ISO 8493:2004 by Technical Committee EC/ISS/TC 29 "Steel tubes and fittings for steel tubes", the secretariat of which is held by UNI.

This European Standard shall be given the status of a national standard, either by publication of an identical text or by endorsement, at the latest by January 2005, and conflicting national standards shall be withdrawn at the latest by January 2005.

This document supersedes EN 10234:1993.

According to the CEN/CENELEC Internal Regulations, the national standards organizations of the following countries are bound to implement this European Standard: Austria, Belgium, Cyprus, Czech Republic, Denmark, Estonia, Finland, France, Germany, Greece, Hungary, Iceland, Ireland, Italy, Latvia, Lithuania, Luxembourg, Malta, Netherlands, Norway, Poland, Portugal, Slovakia, Slovenia, Spain, Sweden, Switzerland and United Kingdom.

Endorsement notice

The text of ISO 8493:1998 has been approved by CEN as EN ISO 8493:2004 without any modifications.

STANDARD PREVIEW
(standards.iteh.ai)
SIST EN ISO 8493:2004
<https://standards.iteh.ai/catalog/standards/sist/46d4994f-fa6f-4cb9-8ada-43e8f766f146/sist-en-iso-8493-2004>

INTERNATIONAL STANDARD

ISO
8493

Second edition
1998-11-01

Metallic materials — Tube — Drift-expanding test

Matériaux métalliques — Tubes — Essai d'évasement

iTeh STANDARD PREVIEW
(standards.iteh.ai)

[SIST EN ISO 8493:2004](https://standards.iteh.ai/catalog/standards/sist/46d4994f-fa6f-4cb9-8ada-43e8f766f146/sist-en-iso-8493-2004)

<https://standards.iteh.ai/catalog/standards/sist/46d4994f-fa6f-4cb9-8ada-43e8f766f146/sist-en-iso-8493-2004>



Reference number
ISO 8493:1998(E)

ISO 8493:1998(E)**Foreword**

ISO (the International Organization for Standardization) is a worldwide federation of national standards bodies (ISO member bodies). The work of preparing International Standards is normally carried out through ISO technical committees. Each member body interested in a subject for which a technical committee has been established has the right to be represented on that committee. International organizations, governmental and non-governmental, in liaison with ISO, also take part in the work. ISO collaborates closely with the International Electrotechnical Commission (IEC) on all matters of electrotechnical standardization.

Draft International Standards adopted by the technical committees are circulated to the member bodies for voting. Publication as an International Standard requires approval by at least 75 % of the member bodies casting a vote.

International Standard ISO 8493 was prepared by Technical Committee ISO/TC 164, *Mechanical testing of metals*, Subcommittee SC 2, *Ductility testing*.

This second edition cancels and replaces the first edition (ISO 8493:1986), of which it constitutes a technical revision.

iTeh STANDARD PREVIEW (standards.iteh.ai)

[SIST EN ISO 8493:2004](https://standards.iteh.ai/catalog/standards/sist/46d4994f-fa6f-4cb9-8ada-43e8f766f146/sist-en-iso-8493-2004)

<https://standards.iteh.ai/catalog/standards/sist/46d4994f-fa6f-4cb9-8ada-43e8f766f146/sist-en-iso-8493-2004>

© ISO 1998

All rights reserved. Unless otherwise specified, no part of this publication may be reproduced or utilized in any form or by any means, electronic or mechanical, including photocopying and microfilm, without permission in writing from the publisher.

International Organization for Standardization
Case postale 56 • CH-1211 Genève 20 • Switzerland
Internet iso@iso.ch

Printed in Switzerland

Metallic materials — Tube — Drift-expanding test

1 Scope

This International Standard specifies a method for determining the ability of metallic tubes of circular cross-section to undergo plastic deformation in drift expansion.

This International Standard is intended for tubes having an outside diameter no greater than 150 mm (100 mm for light metals) and a thickness no greater than 10 mm although the range of the outside diameter or the thickness for which this International Standard is applicable may be more exactly specified in the relevant product standard.

2 Symbols, designations and units

Symbols, designations and units for the drift-expanding test of tubes are given in table 1 and are shown in figure 1.

Table 1

Symbol	Designation	Unit
a^a	Wall thickness of the tube	mm
D	Original outside diameter of the tube	mm
D_u	Maximum outside diameter after testing	mm
L	Length of the test piece before testing	mm
β	Angle of the conical mandrel	degree

^a The symbol T is also used in steel tube standards.

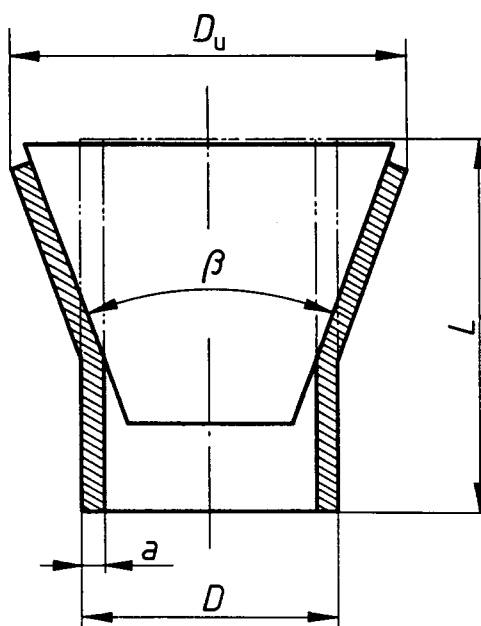

Figure 1

3 Principle

Expansion of the end of the test piece cut from the tube, by means of a conical mandrel, until the maximum outside diameter of the expanded tube reaches the value specified in the relevant product standard (see figure 1).

4 Testing equipment

4.1 Variable-speed press or universal testing machine.

4.2 Conical mandrel, which shall have an angle as specified in the relevant product standard and its surface shall be made of polished material of sufficient hardness.

Preferred angles for the conical mandrel are 30°, 45° and 60°.

5 Test piece

5.1 The length of the test piece depends on the angle of the cone of the drift-expansion conical mandrel. When this angle is equal to or less than 30°, the length of the test piece shall be approximately $L = 2D$. When this angle is greater than 30°, the length of the test piece shall be approximately $L = 1,5D$.

The test piece may be shorter provided that the remaining cylindrical part of the test piece after expansion is at least $0,5D$.

5.2 Both ends of the test piece shall be in the plane perpendicular to the axis of the tube. The edges of the end to be tested may be rounded by filing or chamfered by other methods.

NOTE — Non-rounded or non-chamfered edges are permissible if the test result meets the test requirements.

5.3 When welded tubes are subjected to the test, the internal weld flash may be removed.

6 Procedure

6.1 In general, the test shall be carried out at ambient temperature within the limits of 10 °C to 35 °C. The test carried out under controlled conditions shall be made at a temperature of 23 °C ± 5 °C.

6.2 Force the conical mandrel into the test piece, without shock, until the required outside diameter is reached. The axis of the conical mandrel shall be aligned with the axis of the tube.

The maximum outside diameter of the expanded part of the test piece, D_u , or relative expansion as a percentage of the original diameter, D , shall be specified in the relevant product standard. The angle of the conical mandrel, β , may be specified in the relevant product standard.

When longitudinally welded tubes are subjected to the test, the conical mandrel may be provided with a groove to accommodate an internal weld flash.

6.3 The conical mandrel may be lubricated. It shall not rotate relative to the test piece during the test.

6.4 In case of dispute, the rate of penetration of the conical mandrel shall not exceed 50 mm/min.

6.5 Interpretation of the drift-expanding test shall be carried out in accordance with the requirements of the relevant product standard. When these requirements are not specified, the test piece shall be considered to have passed the test if no cracks are visible without the use of magnifying aids. Slight cracking at the edges shall not be considered cause for rejection.