**Technical systems and aids for disabled or
handicapped persons — Wheelchair
tiedown and occupant-restraint systems —**

Part 2:

Four-point strap-type tiedown systems

iTeh STANDARD PREVIEW

*Assistances et aides techniques pour les personnes invalides ou
handicapées — Systèmes d'attache du fauteuil roulant et de retenue de
l'occupant —*

ISO 10542-2:2001
Partie 2: Systèmes de sangles d'attache à quatre points

<https://standards.iteh.ai/catalog/standards/sist/4d215a75-fd1d-4af4-ab00-755bee41d6dc/iso-10542-2-2001>



PDF disclaimer

This PDF file may contain embedded typefaces. In accordance with Adobe's licensing policy, this file may be printed or viewed but shall not be edited unless the typefaces which are embedded are licensed to and installed on the computer performing the editing. In downloading this file, parties accept therein the responsibility of not infringing Adobe's licensing policy. The ISO Central Secretariat accepts no liability in this area.

Adobe is a trademark of Adobe Systems Incorporated.

Details of the software products used to create this PDF file can be found in the General Info relative to the file; the PDF-creation parameters were optimized for printing. Every care has been taken to ensure that the file is suitable for use by ISO member bodies. In the unlikely event that a problem relating to it is found, please inform the Central Secretariat at the address given below.

iTeh STANDARD PREVIEW
(standards.iteh.ai)

[ISO 10542-2:2001](https://standards.iteh.ai/catalog/standards/sist/4d2f5a75-fdfd-4af4-abd0-755bee41d6dc/iso-10542-2-2001)

<https://standards.iteh.ai/catalog/standards/sist/4d2f5a75-fdfd-4af4-abd0-755bee41d6dc/iso-10542-2-2001>

© ISO 2001

All rights reserved. Unless otherwise specified, no part of this publication may be reproduced or utilized in any form or by any means, electronic or mechanical, including photocopying and microfilm, without permission in writing from either ISO at the address below or ISO's member body in the country of the requester.

ISO copyright office
Case postale 56 • CH-1211 Geneva 20
Tel. + 41 22 749 01 11
Fax + 41 22 749 09 47
E-mail copyright@iso.ch
Web www.iso.ch

Printed in Switzerland

Foreword

ISO (the International Organization for Standardization) is a worldwide federation of national standards bodies (ISO member bodies). The work of preparing International Standards is normally carried out through ISO technical committees. Each member body interested in a subject for which a technical committee has been established has the right to be represented on that committee. International organizations, governmental and non-governmental, in liaison with ISO, also take part in the work. ISO collaborates closely with the International Electrotechnical Commission (IEC) on all matters of electrotechnical standardization.

International Standards are drafted in accordance with the rules given in the ISO/IEC Directives, Part 3.

Draft International Standards adopted by the technical committees are circulated to the member bodies for voting. Publication as an International Standard requires approval by at least 75 % of the member bodies casting a vote.

Attention is drawn to the possibility that some of the elements of this part of ISO 10542 may be the subject of patent rights. ISO shall not be held responsible for identifying any or all such patent rights.

International Standard ISO 10542-2 was prepared by Technical Committee ISO/TC 173, *Technical systems and aids for disabled or handicapped persons*, Subcommittee SC 1, *Wheelchairs*.

ISO 10542 consists of the following parts, under the general title *Technical systems and aids for disabled or handicapped persons — Wheelchair tiedown and occupant-restraint systems*:

- Part 1: *Requirements and test methods for all systems*
- Part 2: *Four-point strap-type tiedown systems*

[ISO 10542-2:2001](https://www.iso.org/standard/755bee41d6dc/iso-10542-2-2001)

Annexes A and B form a normative part of this part of ISO 10542. Annex C is for information only.

<https://www.iso.org/standard/755bee41d6dc/iso-10542-2-2001>

Introduction

Providing effective protection for the wheelchair-seated occupant of a motor vehicle usually requires that after-market equipment be installed to secure the wheelchair and restrain the person in the wheelchair. ISO 10542-1 gives requirements for all wheelchair tiedown and occupant-restraint systems. The provisions of ISO 10542-1 apply except as amended and supplemented by this part of ISO 10542, which gives particular requirements and test methods for wheelchair tiedowns and occupant-restraint systems (WTORS) that use four-point, strap-type wheelchair tiedowns.

iTeh STANDARD PREVIEW (standards.iteh.ai)

[ISO 10542-2:2001](https://standards.iteh.ai/catalog/standards/sist/4d2f5a75-fdfd-4af4-abd0-755bee41d6dc/iso-10542-2-2001)

<https://standards.iteh.ai/catalog/standards/sist/4d2f5a75-fdfd-4af4-abd0-755bee41d6dc/iso-10542-2-2001>

Technical systems and aids for disabled or handicapped persons — Wheelchair tiedown and occupant-restraint systems —

Part 2:

Four-point strap-type tiedown systems

1 Scope

This part of ISO 10542 specifies test methods and requirements for design and performance, for instructions and warnings to installers and users, and for product marking and labelling for wheelchair tiedown and occupant-restraint systems (WTORS).

It applies only to WTORS that use belt-type occupant restraints and four-point strap-type wheelchair tiedowns that are intended for adult-occupied wheelchairs used as forward-facing seats by passengers and drivers of motor vehicles.

This part of ISO 10542 applies primarily to complete WTORS, but other parts of ISO 10542 can also be applied to components and subassemblies sold separately and as replacement parts.

This part of ISO 10542 applies to WTORS intended for use with all types of manual and powered wheelchairs intended for use by adults, including three- and four-wheeled scooters.

2 Normative reference

The following normative document contains provisions which, through reference in this text, constitute provisions of this part of ISO 10542. For dated references, subsequent amendments to, or revisions of, any of these publications do not apply. However, parties to agreements based on this part of ISO 10542 are encouraged to investigate the possibility of applying the most recent edition of the normative document indicated below. For undated references, the latest edition of the normative document referred to applies. Members of ISO and IEC maintain registers of currently valid International Standards.

ISO 10542-1:—¹⁾, *Technical systems and aids for disabled or handicapped persons — Wheelchair tiedown and occupant-restraint systems — Part 1: Requirements and test methods for all systems.*

3 Terms and definitions

For the purposes of this part of ISO 10542, the terms and definitions given in ISO 10542-1 apply.

4 Design requirements

The design requirements of ISO 10542-1 apply with the addition of the following.

1) To be published.

- a) Four-point, strap-type tiedowns shall be designed for effective attachment and tensioning on a wide range of wheelchair types and sizes whilst meeting the angles in Figures 1 and 2, by providing adjustment in strap assembly length, adjustment in the fore/aft location of vehicle anchor points, or both.

NOTE 1 Figure C.1 shows recommended securement point zones on wheelchairs for which a four-point, strap-type tiedown system should be effective.

- b) All securement-point end fittings of four-point tiedown assemblies shall engage with the securement points of the surrogate wheelchair shown and specified in Figure E.1 and Figure E.4 of ISO 10542-1:—.

5 Instructions for installers

In addition to the requirements in 5.2 of ISO 10542-1:—, manufacturers' instructions for installers shall include the recommendations for distances between anchor points of wheelchair tiedowns and the information illustrated in Figures 1 and 2 indicating that:

- a) the side-view projected angle for the rear tiedown straps is between 30° and 45° from the horizontal,
- b) the side-view projected angle for the front tiedown straps is between 40° and 60°,
- c) the rear-view projected angle of the rear tiedown straps is within 10° of the wheelchair reference plane, and
- d) the front-view-projected angle of the front tiedown straps is within 25° of the wheelchair reference plane, but angled so as to provide some lateral stability to the wheelchair.

Dimensions in millimetres

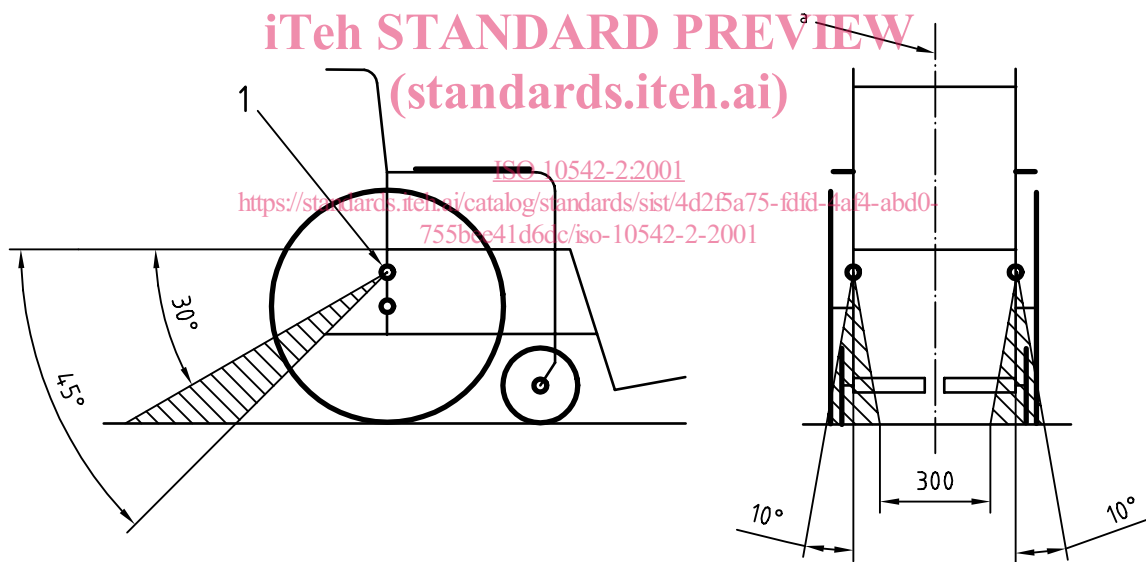

Key
 1 Rear securement points

NOTE The angles shown are obtained by projecting the angle of each tiedown strap onto a vertical plane parallel to (side view) or perpendicular to (rear view) the wheelchair reference plane.

^a Wheelchair reference plane

Figure 1 — Preferred angles of rear wheelchair-tiedown straps and locations of tiedown anchor points

Dimensions in millimetres

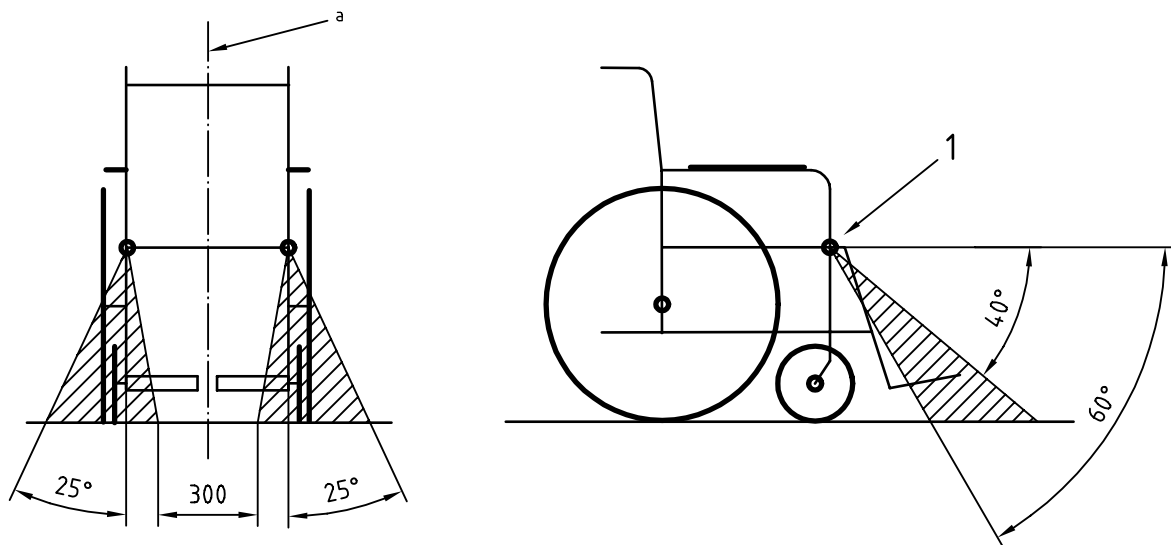
**Key**

1 Front securement points

NOTE The angles shown are obtained by projecting the angle of each tiedown strap onto a vertical plane parallel to (side view) or perpendicular to (rear view) the wheelchair reference plane.

a Wheelchair reference plane

Figure 2 — Preferred angles of front tiedown straps and locations of tiedown anchor points

6 User and maintenance instructions

ISO 10542-2:2001

[https://standards.iteh.ai/catalog/standards/sist/4d2f5a75-fdfd-4af4-abd0-](https://standards.iteh.ai/catalog/standards/sist/4d2f5a75-fdfd-4af4-abd0-755bee41d6dc/iso-10542-2-2001)

[755bee41d6dc/iso-10542-2-2001](https://standards.iteh.ai/catalog/standards/sist/4d2f5a75-fdfd-4af4-abd0-755bee41d6dc/iso-10542-2-2001)

In addition to the requirements in 5.3 of ISO 10542-1:—, manufacturers' instructions for users shall include recommendations for preferred angles of tiedown strap assemblies and Figures 1 and 2, including statements that, whenever possible,

- the side-view projected angle for the rear tiedown straps should be between 30° and 45° from the horizontal,
- the side-view projected angle for the front tiedown straps should be between 40° and 60° ,
- the rear-view projected angle of the rear tiedown straps should be within 10° of the wheelchair reference plane, and
- the front-view-projected angle of the front tiedown straps should be within 25° of the wheelchair reference plane, and angled laterally so as to provide some lateral stability to the wheelchair.

Annex A (normative)

Test method for frontal impact testing of WTORS with tiedowns having four adjustable-length strap assemblies

A.1 Principle

ISO 10542-1:—, annex A, specifies methods for dynamically testing a WTORS in a frontal impact and indicates that the WTORS should be installed and the wheelchair secured using the WTORS manufacturer's instructions and recommendations. These procedures should also be followed when testing WTORS that include four-point, strap-type tiedowns with two or more fixed-length strap assemblies. For four-point tiedowns with four adjustable-length strap assemblies and four longitudinally fixed anchor points, the angles and lengths of the strap assemblies can have an effect on test results. To reduce variability in results obtained from testing a given WTORS within and between laboratories, it is desirable to specify a consistent method for setting up the pre-test geometry.

A.2 Purpose and rationale

This annex specifies additional requirements to the test set-up procedures specified in ISO 10542-1:—, A.4, when testing a WTORS that uses a four-point, strap-type tiedown with four adjustable-length strap assemblies. The procedures specified in A.3 are based on typical and expected conditions in actual vehicles, but are not intended to be representative of all real-world situations.

A.3 Modifications to wheelchair tiedown set-up procedures

A.3.1 The procedures specified in ISO 10542-1:—, A.4, apply with the exception that A.4.7 shall be replaced by A.3.2 through A.3.4 of this part of ISO 10542.

A.3.2 Secure the SWC with the four-point tiedown, selecting anchor points that

- a) are symmetrical about the wheelchair reference plane,
- b) are located $1\ 300\ \text{mm} \pm 20\ \text{mm}$ from the front anchor point to the rear anchor point,
- c) have a lateral distance between rear anchor points equal to the lateral distance between rear securement points of the surrogate wheelchair, $\pm 25\ \text{mm}$, and
- d) have a lateral distance between front anchor points of $300\ \text{mm}$ to $810\ \text{mm}$.

NOTE For purposes of locating the anchor points, the front-to-back location of an anchor point is the location of the primary fastener that secures the anchorage to the test platform or, in the case of multiple fasteners, the centre of these fasteners. The lateral location of an anchor point is considered to be the centre of the location where the tiedown end fitting contacts the anchorage hardware attached to the test platform.

A.3.3 Secure the surrogate wheelchair in accordance with the WTORS manufacturer's instructions to achieve lengths of the rear tiedown strap assemblies of $495\ \text{mm}$ to $533\ \text{mm}$, measured from the interface of the tiedown end fitting and the securement point on the wheelchair to the anchor point.

NOTE For purposes of measuring the rear tiedown length, the anchor point is considered to be the point at which a straight line along the length of the strap assembly intersects with the wheelchair ground plane.

A.3.4 Tension adjustable-length tiedown straps to the manufacturer's specifications, making sure that the SWC reference plane is parallel to the centreline of the impact simulator within $\pm 3^\circ$.

Annex B (normative)

Test methods for measuring occupant-restraint belt lengths and geometry

B.1 Principle

ISO 10542-1:—, annex B, specifies methods for setting up and measuring occupant-restraint belt geometry on the ATD and length adjustments to ensure that the restraint system will accommodate a wide range of user situations and wheelchair sizes. These methods use the wheelchair securement procedures specified in annex A of ISO 10542-1:—. For WTORS with four-point, strap-type tiedowns having four adjustable-length strap assemblies and four longitudinally fixed anchor points, annex A of this part of ISO 10542 specifies additional procedures for securing a wheelchair that are to be used in conjunction with ISO 10542-1:—, A.4. These same additional procedures for securing a wheelchair should be used when setting up WTORS in accordance with ISO 10542-1:—, annex B to measure occupant-restraint belt geometry and lengths.

B.2 Modifications to test set-up procedures

Clauses B.1 to B.6 of ISO 10542-1:— apply, with the exception that, when securing the surrogate wheelchair with strap-type tiedowns having four adjustable-length strap assemblies and four longitudinally fixed anchor points, select tiedown anchor points and position the surrogate wheelchair in accordance with annex A.

iTeh STANDARD PREVIEW
(standards.iteh.ai)

[ISO 10542-2:2001](https://standards.iteh.ai/catalog/standards/sist/4d2f5a75-fdfd-4af4-abd0-755bee41d6dc/iso-10542-2-2001)

<https://standards.iteh.ai/catalog/standards/sist/4d2f5a75-fdfd-4af4-abd0-755bee41d6dc/iso-10542-2-2001>