



SLOVENSKI STANDARD

SIST EN 13286-52:2005

01-junij-2005

BYj YnUbY]b\]XfUj`] bc`j YnUbY`na Yg]`E) &`XY. `DcglcdY_`fa YrcXU`nUdf]dfUj c
dfY]n_i yUbWj`]n\]XfUj`] bc`j YnUb]` na Yg]ždf]dfUj` ^yb]` n`j]VfUW]g_]a
n[cy` Yj Ub]_ca

Unbound and hydraulically bound mixtures - Part 52: Method for the manufacture of test specimens of hydraulically bound mixtures using vibrocompression

iTeh STANDARD PREVIEW

Ungebundene und hydraulisch gebundene Gemische Teil 52: Verfahren zur Herstellung von Probekörpern von hydraulisch gebundenen Gemischen durch Vibro-Druck (Rütteln und Druck)

[SIST EN 13286-52:2005](https://standards.iteh.ai/catalog/standards/sist/71460ccb-986a-45c5-8775-3532483644fa/sist-en-13286-52-2005)

[https://standards.iteh.ai/catalog/standards/sist/71460ccb-986a-45c5-8775-](https://standards.iteh.ai/catalog/standards/sist/71460ccb-986a-45c5-8775-3532483644fa/sist-en-13286-52-2005)

[3532483644fa/sist-en-13286-52-2005](https://standards.iteh.ai/catalog/standards/sist/71460ccb-986a-45c5-8775-3532483644fa/sist-en-13286-52-2005)

Mélanges traités et mélanges non traités aux liants hydrauliques - Partie 52: Méthode de confection par vibrocompression des éprouvettes de matériaux traités aux liants hydrauliques

Ta slovenski standard je istoveten z: EN 13286-52:2004

ICS:

93.080.20 Materiali za gradnjo cest Road construction materials

SIST EN 13286-52:2005 en

iTeh STANDARD PREVIEW
(standards.iteh.ai)

[SIST EN 13286-52:2005](https://standards.iteh.ai/catalog/standards/sist/71460ccb-986a-45c5-8775-3532483644fa/sist-en-13286-52-2005)

<https://standards.iteh.ai/catalog/standards/sist/71460ccb-986a-45c5-8775-3532483644fa/sist-en-13286-52-2005>

EUROPEAN STANDARD
NORME EUROPÉENNE
EUROPÄISCHE NORM

EN 13286-52

December 2004

ICS 93.080.20

English version

**Unbound and hydraulically bound mixtures - Part 52: Method for
the manufacture of test specimens of hydraulically bound
mixtures using vibrocompression**

Mélanges traités et mélanges non traités aux liants
hydrauliques - Partie 52: Méthode de confection par
vibrocompression des éprouvettes de matériaux traités aux
liants hydrauliques

Ungebundene und hydraulisch gebundene Gemische - Teil
52: Verfahren zur Herstellung von Probekörpern von
hydraulisch gebundenen Gemischen durch Vibro-Druck
(Rütteln und Druck)

This European Standard was approved by CEN on 12 November 2004.

CEN members are bound to comply with the CEN/CENELEC Internal Regulations which stipulate the conditions for giving this European Standard the status of a national standard without any alteration. Up-to-date lists and bibliographical references concerning such national standards may be obtained on application to the Central Secretariat or to any CEN member.

This European Standard exists in three official versions (English, French, German). A version in any other language made by translation under the responsibility of a CEN member into its own language and notified to the Central Secretariat has the same status as the official versions.

CEN members are the national standards bodies of Austria, Belgium, Cyprus, Czech Republic, Denmark, Estonia, Finland, France, Germany, Greece, Hungary, Iceland, Ireland, Italy, Latvia, Lithuania, Luxembourg, Malta, Netherlands, Norway, Poland, Portugal, Slovakia, Slovenia, Spain, Sweden, Switzerland and United Kingdom.



EUROPEAN COMMITTEE FOR STANDARDIZATION
COMITÉ EUROPÉEN DE NORMALISATION
EUROPÄISCHES KOMITEE FÜR NORMUNG

Management Centre: rue de Stassart, 36 B-1050 Brussels

Contents

	Page
Foreword.....	3
1 Scope	5
2 Terms and definitions	5
3 Principle.....	5
4 Dimensions of the specimens	5
5 Apparatus	6
6 Procedure	7
7 Storage.....	8
8 Test report	8

iTeh STANDARD PREVIEW (standards.iteh.ai)

[SIST EN 13286-52:2005](https://standards.iteh.ai/catalog/standards/sist/71460ccb-986a-45c5-8775-3532483644fa/sist-en-13286-52-2005)

<https://standards.iteh.ai/catalog/standards/sist/71460ccb-986a-45c5-8775-3532483644fa/sist-en-13286-52-2005>

Foreword

This document (EN 13286-52:2004) has been prepared by Technical Committee CEN/TC 227 "Road materials", the secretariat of which is held by DIN.

This European Standard shall be given the status of a national standard, either by publication of an identical text or by endorsement, at the latest by June 2005, and conflicting national standards shall be withdrawn at the latest by June 2005.

This document is one of a series of documents as listed below.

EN 13286-1, *Unbound and hydraulically bound mixtures — Part 1: Test methods for laboratory reference density and water content — Introduction, general requirements and sampling*

EN 13286-2, *Unbound and hydraulically bound mixtures — Part 2: Test methods for the determination of the laboratory reference density and water content — Proctor compaction*

EN 13286-3, *Unbound and hydraulically bound mixtures — Part 3: Test methods for laboratory reference density and water content — Vibrocompression with controlled parameters*

EN 13286-4, *Unbound and hydraulically bound mixtures — Part 4: Test methods for laboratory reference density and water content — Vibrating hammer*

EN 13286-5, *Unbound and hydraulically bound mixtures — Part 5: Test methods for laboratory reference density and water content — Vibrating table*

<https://standards.iteh.ai/catalog/standards/sist/71460ccb-986a-45c5-8775-1ca60000-0000/en-13286-52-5>

EN 13286-7, *Unbound and hydraulically bound mixtures — Part 7: Cyclic load triaxial test for unbound mixtures*

EN 13286-40, *Unbound and hydraulically bound mixtures — Part 40: Test method for the determination of the direct tensile strength of hydraulically bound mixtures*

EN 13286-41, *Unbound and hydraulically bound mixtures — Part 41: Test method for the determination of the compressive strength of hydraulically bound mixtures*

EN 13286-42, *Unbound and hydraulically bound mixtures — Part 42: Test method for the determination of the indirect tensile strength of hydraulically bound mixtures*

EN 13286-43, *Unbound and hydraulically bound mixtures — Part 43: Test method for the determination of the modulus of elasticity of hydraulically bound mixtures*

EN 13286-44, *Unbound and hydraulically bound mixtures — Part 44: Test method for the determination of the alpha coefficient of vitrified blast furnace slag*

EN 13286-45, *Unbound and hydraulically bound mixtures — Part 45: Test method for the determination of the workability period of hydraulically bound mixtures*

EN 13286-46, *Unbound and hydraulically bound mixtures — Part 46: Test method for the determination of the moisture condition value*

EN 13286-47, *Unbound and hydraulically bound mixtures — Part 47: Test method for the determination of California bearing ratio, immediate bearing index and linear swelling*

EN 13286-52:2004 (E)

prEN 13286-48, *Unbound and hydraulically bound mixtures — Part 48: Test method for the determination of degree of pulverisation*

EN 13286-49, *Unbound and hydraulically bound mixtures — Part 49: Accelerated swelling test for soil treated by lime and/or hydraulic binder*

EN 13286-50, *Unbound and hydraulically bound mixtures — Part 50: Method for the manufacture of test specimens of hydraulically bound mixtures using Proctor equipment or vibrating table compaction*

EN 13286-51, *Unbound and hydraulically bound mixtures — Part 51: Method for the manufacture of test specimens of hydraulically bound mixtures using vibrating hammer compaction*

EN 13286-52, *Unbound and hydraulically bound mixtures — Part 52: Method for the manufacture of test specimens of hydraulically bound mixtures using vibrocompression*

EN 13286-53, *Unbound and hydraulically bound mixtures — Part 53: Methods for the manufacture of test specimens of hydraulically bound mixtures using axial compression*

According to the CEN/CENELEC Internal Regulations, the national standards organizations of the following countries are bound to implement this European Standard: Austria, Belgium, Cyprus, Czech Republic, Denmark, Estonia, Finland, France, Germany, Greece, Hungary, Iceland, Ireland, Italy, Latvia, Lithuania, Luxembourg, Malta, Netherlands, Norway, Poland, Portugal, Slovakia, Slovenia, Spain, Sweden, Switzerland and United Kingdom.

iTeh STANDARD PREVIEW **(standards.iteh.ai)**

[SIST EN 13286-52:2005](https://standards.iteh.ai/catalog/standards/sist/71460ccb-986a-45c5-8775-3532483644fa/sist-en-13286-52-2005)

<https://standards.iteh.ai/catalog/standards/sist/71460ccb-986a-45c5-8775-3532483644fa/sist-en-13286-52-2005>

1 Scope

This document specifies a test method for making specimens of hydraulically bound mixture to a predetermined density and water content by vibrocompression compaction.

This document is appropriate to mixtures, or that part of a mixture, containing aggregate up to a maximum size of 31,5 mm.

This method is not applicable to mixtures with a high proportion of fines.

2 Terms and definitions

For the purposes of this document, the following term and definition applies.

2.1

vibrocompression compaction

method of compaction of a laboratory specimen by the simultaneous application of horizontal vibration and light axial compression

3 Principle

The mixture is placed in a mould of a given volume. The mixture is compacted with a combination of horizontal vibration and vertical axial pressure.

4 Dimensions of the specimens

<https://standards.iteh.ai/catalog/standards/sist/71460ccb-986a-45c5-8775-3532483644fa/sist-en-13286-52-2005>

4.1 Cylindrical specimens

Specimens shall conform to the dimensions given in Table 1.

Table 1 — Dimensions of the specimen

Column	1	2	3
Line	Diameter, <i>d</i> mm	Height, <i>h</i> mm	Maximum size of particle permitted in the specimen mm
1	100	100 or 200	22,4
2	160	160 or 320	31,5

4.2 Direct tensile test specimens

Specimens for direct tensile test shall have the shape and dimensions in millimetres shown in Figure 1.

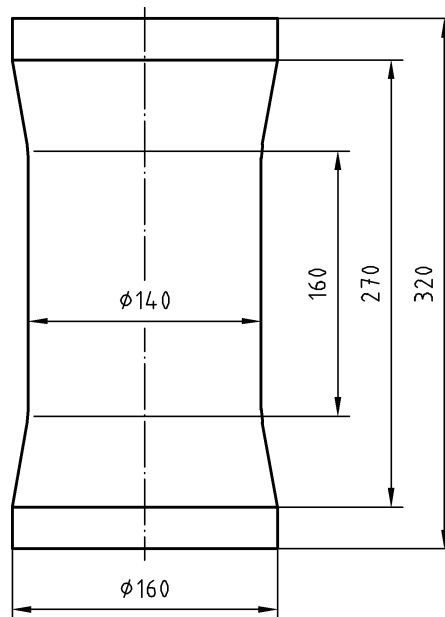

Figure 1 — Shape and dimension of a tensile test specimen

ITeH STANDARD PREVIEW
(standards.iteh.ai)

5 Apparatus

5.1 Moulds

SIST EN 13286-52:2005

[https://standards.iteh.ai/catalog/standards/sist/71460ccb-986a-45c5-8775-](https://standards.iteh.ai/catalog/standards/sist/71460ccb-986a-45c5-8775-3532483644fa/sist-en-13286-52-2005)

[3532483644fa/sist-en-13286-52-2005](https://standards.iteh.ai/catalog/standards/sist/71460ccb-986a-45c5-8775-3532483644fa/sist-en-13286-52-2005)

5.1.1 Moulds, made from rigid materials, e.g. plastic or similar, with a volume accuracy of $\pm 1,5\%$ of the nominal volume of the specimen.

5.1.2 Moulds shall be tubes to which caps can be attached to cover each end of the specimens after compaction in order to prevent loss of moisture during storage.

5.1.3 Moulds for cylindrical specimens (see Figure 2) shall be cut on one generatrix to allow slight opening of the mould in order to remove the specimen after setting.

5.1.4 Moulds for direct tensile testing shall be capable of producing cylindrical specimens with a cross section shown in Figure 1 and shall be split on two opposite generatrix in order to remove the specimen after setting.

5.2 Compaction apparatus (see Figure 2)

5.2.1 **Cylinder**, to stiffen the mould and lengthen the top end of the mould to allow introduction of the mixture before compaction.

5.2.2 **Plate**, to close the bottom of the mould.

5.2.3 **Vibrator**, to apply a horizontal vibration to the mould and the mixture with a frequency of 100 Hz and an amplitude between 0,8 mm and 1 mm. The vibration shall be sufficient to compact the specimen to the required density within 90 s using a pressure on the mixture not greater than 0,5 MPa.

5.2.4 **Piston**, to apply an increasing vertical pulse pressure on the mixture during compaction.

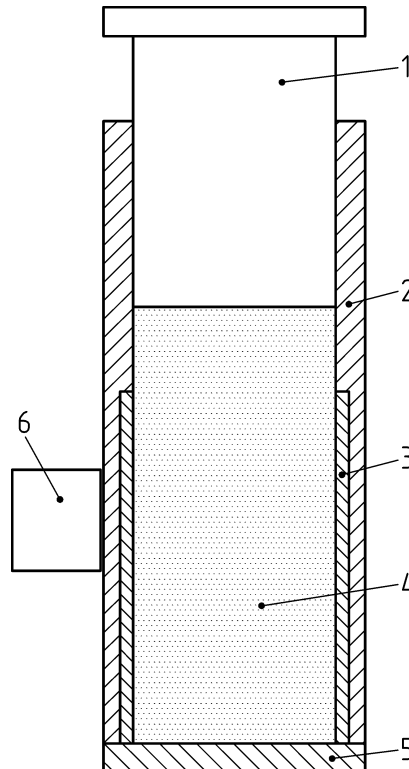

iTeh STANDARD PREVIEW
(standards.iteh.ai)

Key

- 1 piston
- 2 cylinder to stiffen the mould
- 3 cylinder mould
- 4 mixture to be compacted
- 5 plate to close the bottom of the mould
- 6 vibrator

[SIST EN 13286-52:2005](#)

[standards.iteh.ai/catalog/standards/sist/71460ccb-986a-45c5-8775-](#)

[35b2483644fa/sist-en-13286-52-2005](#)

Figure 2 — Principle of vibrocompression apparatus

6 Procedure

6.1 Place the mould in the cylinder and close the bottom of the apparatus by means of the plate.

6.2 Introduce the mixture into the apparatus.

The mass of the mixture to be introduced into the apparatus shall be measured to an accuracy of $\pm 1\%$ and is given by the following formula:

$$m = 1\,000 V \times \rho_d \frac{(100 + w)}{100}$$

where

m is the mass of the mixture to be introduced in the mould, in grams (g);

V is the volume of the specimen, in cubic millimetres (mm³);

ρ_d is the dry density of the specimen, in megagrams per cubic metre (Mg/m³);

w is the water content of the dry mass of the mixture, in percent (%).