

# INTERNATIONAL STANDARD

# NORME INTERNATIONALE

Photovoltaic devices –  
Part 2: Requirements for photovoltaic reference devices

Dispositifs photovoltaïques –  
Partie 2: Exigences applicables aux dispositifs photovoltaïques de référence

STANDARD PREVIEW  
(standards.iteh.ai)

IEC 60904-2:2015

<https://standards.iteh.ai/catalog/standards/sist/07af9090-c207-4144-80d8-ce687514c434/iec-60904-2-2015>



## THIS PUBLICATION IS COPYRIGHT PROTECTED

Copyright © 2015 IEC, Geneva, Switzerland

All rights reserved. Unless otherwise specified, no part of this publication may be reproduced or utilized in any form or by any means, electronic or mechanical, including photocopying and microfilm, without permission in writing from either IEC or IEC's member National Committee in the country of the requester. If you have any questions about IEC copyright or have an enquiry about obtaining additional rights to this publication, please contact the address below or your local IEC member National Committee for further information.

Droits de reproduction réservés. Sauf indication contraire, aucune partie de cette publication ne peut être reproduite ni utilisée sous quelque forme que ce soit et par aucun procédé, électronique ou mécanique, y compris la photocopie et les microfilms, sans l'accord écrit de l'IEC ou du Comité national de l'IEC du pays du demandeur. Si vous avez des questions sur le copyright de l'IEC ou si vous désirez obtenir des droits supplémentaires sur cette publication, utilisez les coordonnées ci-après ou contactez le Comité national de l'IEC de votre pays de résidence.

IEC Central Office  
3, rue de Varembe  
CH-1211 Geneva 20  
Switzerland

Tel.: +41 22 919 02 11  
Fax: +41 22 919 03 00  
[info@iec.ch](mailto:info@iec.ch)  
[www.iec.ch](http://www.iec.ch)

### About the IEC

The International Electrotechnical Commission (IEC) is the leading global organization that prepares and publishes International Standards for all electrical, electronic and related technologies.

### About IEC publications

The technical content of IEC publications is kept under constant review by the IEC. Please make sure that you have the latest edition, a corrigenda or an amendment might have been published.

#### IEC Catalogue - [webstore.iec.ch/catalogue](http://webstore.iec.ch/catalogue)

The stand-alone application for consulting the entire bibliographical information on IEC International Standards, Technical Specifications, Technical Reports and other documents. Available for PC, Mac OS, Android Tablets and iPad.

#### IEC publications search - [www.iec.ch/searchpub](http://www.iec.ch/searchpub)

The advanced search enables to find IEC publications by a variety of criteria (reference number, text, technical committee,...). It also gives information on projects, replaced and withdrawn publications.

#### IEC Just Published - [webstore.iec.ch/justpublished](http://webstore.iec.ch/justpublished)

Stay up to date on all new IEC publications. Just Published details all new publications released. Available online and also once a month by email.

#### Electropedia - [www.electropedia.org](http://www.electropedia.org)

The world's leading online dictionary of electronic and electrical terms containing more than 30 000 terms and definitions in English and French, with equivalent terms in 15 additional languages. Also known as the International Electrotechnical Vocabulary (IEV) online.

#### IEC Glossary - [std.iec.ch/glossary](http://std.iec.ch/glossary)

More than 60 000 electrotechnical terminology entries in English and French extracted from the Terms and Definitions clause of IEC publications issued since 2002. Some entries have been collected from earlier publications of IEC TC 37, 77, 86 and CISPR.

#### IEC Customer Service Centre - [webstore.iec.ch/csc](http://webstore.iec.ch/csc)

If you wish to give us your feedback on this publication or need further assistance, please contact the Customer Service Centre: [csc@iec.ch](mailto:csc@iec.ch).

### A propos de l'IEC

La Commission Electrotechnique Internationale (IEC) est la première organisation mondiale qui élabore et publie des Normes internationales pour tout ce qui a trait à l'électricité, à l'électronique et aux technologies apparentées.

### A propos des publications IEC

Le contenu technique des publications IEC est constamment revu. Veuillez vous assurer que vous possédez l'édition la plus récente, un corrigendum ou amendement peut avoir été publié.

#### Catalogue IEC - [webstore.iec.ch/catalogue](http://webstore.iec.ch/catalogue)

Application autonome pour consulter tous les renseignements bibliographiques sur les Normes internationales, Spécifications techniques, Rapports techniques et autres documents de l'IEC. Disponible pour PC, Mac OS, tablettes Android et iPad.

#### Recherche de publications IEC - [www.iec.ch/searchpub](http://www.iec.ch/searchpub)

La recherche avancée permet de trouver des publications IEC en utilisant différents critères (numéro de référence, texte, comité d'études,...). Elle donne aussi des informations sur les projets et les publications remplacées ou retirées.

#### IEC Just Published - [webstore.iec.ch/justpublished](http://webstore.iec.ch/justpublished)

Restez informé sur les nouvelles publications IEC. Just Published détaille les nouvelles publications parues. Disponible en ligne et aussi une fois par mois par email.

#### Electropedia - [www.electropedia.org](http://www.electropedia.org)

Le premier dictionnaire en ligne de termes électroniques et électriques. Il contient plus de 30 000 termes et définitions en anglais et en français, ainsi que les termes équivalents dans 15 langues additionnelles. Egalement appelé Vocabulaire Electrotechnique International (IEV) en ligne.

#### Glossaire IEC - [std.iec.ch/glossary](http://std.iec.ch/glossary)

Plus de 60 000 entrées terminologiques électrotechniques, en anglais et en français, extraites des articles Termes et Définitions des publications IEC parues depuis 2002. Plus certaines entrées antérieures extraites des publications des CE 37, 77, 86 et CISPR de l'IEC.

#### Service Clients - [webstore.iec.ch/csc](http://webstore.iec.ch/csc)

Si vous désirez nous donner des commentaires sur cette publication ou si vous avez des questions contactez-nous: [csc@iec.ch](mailto:csc@iec.ch).



IEC 60904-2

Edition 3.0 2015-01

# INTERNATIONAL STANDARD

# NORME INTERNATIONALE

Photovoltaic devices – **STANDARD PREVIEW**  
Part 2: Requirements for photovoltaic reference devices  
(standards.iteh.ai)

Dispositifs photovoltaïques – **IEC 60904-2:2015**  
Partie 2: Exigences applicables aux dispositifs photovoltaïques de référence  
ce687514c434/iec-60904-2-2015

INTERNATIONAL  
ELECTROTECHNICAL  
COMMISSION

COMMISSION  
ELECTROTECHNIQUE  
INTERNATIONALE

ICS 27.160

ISBN 978-2-8322-2184-6

**Warning! Make sure that you obtained this publication from an authorized distributor.**  
**Attention! Veuillez vous assurer que vous avez obtenu cette publication via un distributeur agréé.**

## CONTENTS

FOREWORD.....	3
1 Scope.....	5
2 Normative references.....	5
3 Terms and definitions .....	5
4 Selection of reference device .....	7
4.1 General requirements.....	7
4.2 Additional requirements for single reference cell in a multi-cell package .....	8
4.3 Additional requirements for reference modules .....	8
4.4 Requirements for built-in shunt resistors .....	8
5 Temperature measurement .....	9
6 Electrical connections .....	9
7 Calibration.....	9
8 Report.....	10
9 Marking .....	11
10 Packaging .....	11
10.1 Recommended packaging for use in natural sunlight.....	11
10.2 Recommended packaging for use under solar simulators .....	11
10.3 Single cell package .....	11
11 Care of reference devices .....	12
12 Calibration of secondary reference devices against a primary reference cell .....	12
12.1 General.....	12
12.2 Natural sunlight.....	12
12.3 Simulated sunlight.....	13
12.4 Test procedure.....	13
13 Calibration of working reference device against a secondary reference device .....	14
Bibliography .....	15
Figure 1 – Single-cell package .....	6
Figure 2 – Single reference cell in a multi-cell package.....	8

iTab STANDARD PREVIEW

(standards.iteh.ai)

[standards.iteh.ai/catalog/standards/sist/67af5b90-c267-4f44-8ad8-ce687514c434/iec-60904-2-2015](https://standards.iteh.ai/catalog/standards/sist/67af5b90-c267-4f44-8ad8-ce687514c434/iec-60904-2-2015)

## INTERNATIONAL ELECTROTECHNICAL COMMISSION

## PHOTOVOLTAIC DEVICES –

## Part 2: Requirements for photovoltaic reference devices

## FOREWORD

- 1) The International Electrotechnical Commission (IEC) is a worldwide organization for standardization comprising all national electrotechnical committees (IEC National Committees). The object of IEC is to promote international co-operation on all questions concerning standardization in the electrical and electronic fields. To this end and in addition to other activities, IEC publishes International Standards, Technical Specifications, Technical Reports, Publicly Available Specifications (PAS) and Guides (hereafter referred to as "IEC Publication(s)"). Their preparation is entrusted to technical committees; any IEC National Committee interested in the subject dealt with may participate in this preparatory work. International, governmental and non-governmental organizations liaising with the IEC also participate in this preparation. IEC collaborates closely with the International Organization for Standardization (ISO) in accordance with conditions determined by agreement between the two organizations.
- 2) The formal decisions or agreements of IEC on technical matters express, as nearly as possible, an international consensus of opinion on the relevant subjects since each technical committee has representation from all interested IEC National Committees.
- 3) IEC Publications have the form of recommendations for international use and are accepted by IEC National Committees in that sense. While all reasonable efforts are made to ensure that the technical content of IEC Publications is accurate, IEC cannot be held responsible for the way in which they are used or for any misinterpretation by any end user.
- 4) In order to promote international uniformity, IEC National Committees undertake to apply IEC Publications transparently to the maximum extent possible in their national and regional publications. Any divergence between any IEC Publication and the corresponding national or regional publication shall be clearly indicated in the latter.
- 5) IEC itself does not provide any attestation of conformity. Independent certification bodies provide conformity assessment services and, in some areas, access to IEC marks of conformity. IEC is not responsible for any services carried out by independent certification bodies.
- 6) All users should ensure that they have the latest edition of this publication.
- 7) No liability shall attach to IEC or its directors, employees, servants or agents including individual experts and members of its technical committees and IEC National Committees for any personal injury, property damage or other damage of any nature whatsoever, whether direct or indirect, or for costs (including legal fees) and expenses arising out of the publication, use of, or reliance upon, this IEC Publication or any other IEC Publications.
- 8) Attention is drawn to the Normative references cited in this publication. Use of the referenced publications is indispensable for the correct application of this publication.
- 9) Attention is drawn to the possibility that some of the elements of this IEC Publication may be the subject of patent rights. IEC shall not be held responsible for identifying any or all such patent rights.

International Standard IEC 60904-2 has been prepared by IEC Technical Committee 82: Solar photovoltaic energy systems.

This third edition cancels and replaces the second edition, published in 2007. It constitutes a technical revision.

The main technical changes with regard to the previous edition are as follows:

- addition of a test procedure in simulated sunlight of subsequent measurement of primary and secondary reference device;
- definition of standard test conditions;
- reduction of allowed diffuse component for secondary reference cell calibration to 20 %.

The text of this standard is based on the following documents:

FDIS	Report on voting
82/893/FDIS	82/918/RVD

Full information on the voting for the approval of this standard can be found in the report on voting indicated in the above table.

This publication has been drafted in accordance with the ISO/IEC Directives, Part 2.

A list of all parts in the IEC 60904 series, published under the general title *Photovoltaic devices*, can be found on the IEC website.

The committee has decided that the contents of this publication will remain unchanged until the stability date indicated on the IEC website under "<http://webstore.iec.ch>" in the data related to the specific publication. At this date, the publication will be

- reconfirmed,
- withdrawn,
- replaced by a revised edition, or
- amended.

## iTeh STANDARD PREVIEW (standards.iteh.ai)

[IEC 60904-2:2015](#)

<https://standards.iteh.ai/catalog/standards/sist/67af5b90-c267-4f44-8ad8-ce687514c434/iec-60904-2-2015>

## PHOTOVOLTAIC DEVICES –

### Part 2: Requirements for photovoltaic reference devices

#### 1 Scope

This part of IEC 60904 gives requirements for the classification, selection, packaging, marking, calibration and care of photovoltaic reference devices.

This standard covers photovoltaic reference devices used to determine the electrical performance of photovoltaic cells, modules and arrays under natural and simulated sunlight. It does not cover photovoltaic reference devices for use under concentrated sunlight.

#### 2 Normative references

The following documents, in whole or in part, are normatively referenced in this document and are indispensable for its application. For dated references, only the edition cited applies. For undated references, the latest edition of the referenced document (including any amendments) applies.

IEC 60891, *Photovoltaic devices – Procedures for temperature and irradiance corrections to measured I-V characteristics* (standards.iteh.ai)

IEC 60904-1, *Photovoltaic devices – Part 1: Measurements of photovoltaic current-voltage characteristics* <https://standards.iteh.ai/catalog/standards/sist/67af5b90-c267-4f44-8ad8-ce687514c434/iec-60904-2-2015>

IEC 60904-3, *Photovoltaic devices – Part 3: Measurement principles for terrestrial photovoltaic (PV) solar devices with reference spectral irradiance data*

IEC 60904-4, *Photovoltaic devices – Part 4: Reference solar devices – Procedures for establishing calibration traceability*

IEC 60904-5, *Photovoltaic devices – Part 5: Determination of the equivalent cell temperature (ECT) of photovoltaic (PV) devices by the open-circuit voltage method*

IEC 60904-7, *Photovoltaic devices – Part 7: Computation of the spectral mismatch correction for measurements of photovoltaic devices*

IEC 60904-8, *Photovoltaic devices – Part 8: Measurement of spectral responsivity of a photovoltaic (PV) device*

IEC 60904-9, *Photovoltaic devices – Part 9: Solar simulator performance requirements*

IEC 60904-10, *Photovoltaic devices – Part 10: Methods of linearity measurement*

IEC TS 61836, *Solar photovoltaic energy systems – Terms, definitions and symbols*

#### 3 Terms and definitions

For the purposes of this document, the terms and definitions given in IEC TS 61836 and the following apply.

**3.1 calibration traceability**

traceability as defined in IEC 60904-4

Note 1 to entry: Photovoltaic reference devices are distinguished by their position in a chain of calibration traceability.

**3.2 primary reference device**

photovoltaic reference device whose calibration is based on a radiometer or standard detector or standard light source traceable to SI units as defined in IEC 60904-4

**3.3 secondary reference device**

photovoltaic reference device calibrated in natural or simulated sunlight against a primary reference device

**3.4 working reference device**

photovoltaic reference device calibrated in natural or simulated sunlight against a secondary reference device

**3.5 reference devices**

specially calibrated photovoltaic devices which are used to measure natural or simulated irradiance or to set simulator irradiance levels for measuring the performance of other photovoltaic devices

**3.6 reference cell**

single photovoltaic cell used primarily for transfer of calibration values

STANDARD PREVIEW  
(standards.iteh.ai)  
IEC 60904-2:2015  
<http://standards.iteh.ai/catalog/standards/sist/671f5b99-c267-4f14-8ad8-ce687514c434/iec-60904-2-2015>

Note 1 to entry: For practical reasons, such cells are small in surface area, and are usually mounted on a fixture which ensures reproducibility in mounting, thermal control and electrical connections. A typical sample is sketched in Figure 1.

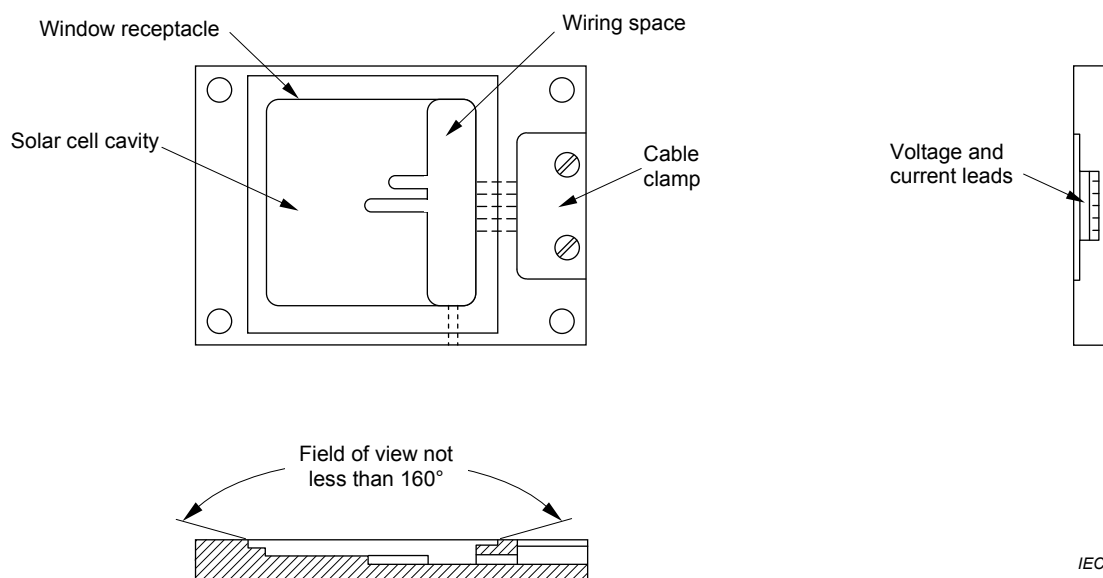

IEC

**Figure 1 – Single-cell package**

**3.6.1 reference cell with protective cover but without encapsulant**

photovoltaic reference cell similar to 3.6, but provided with a protective cover



Note 1 to entry: Recommended use: as a laboratory primary, secondary and working reference, in particular when measuring the performance of other photovoltaic devices using solar simulators or natural sunlight with direct beam only.

### 3.6.2

#### **encapsulated reference cell**

photovoltaic reference cell similar to 3.6, but encapsulated in a protective assembly so as to withstand short-term outdoor exposure

Note 1 to entry: Recommended use: as a laboratory primary, secondary and working reference, in particular when measurements of the performance of other photovoltaic devices under natural sunlight are performed.

Note 2 to entry: If the encapsulation system has been demonstrated to withstand long-term outdoor exposure, applying test levels according to IEC 61215, such reference cells may also be suitable to be used as a monitoring device for long-term assessment of operational photovoltaic arrays.

### 3.7

#### **multi-cell reference devices**

photovoltaic device consisting of several photovoltaic cells

Note 1 to entry: Recommended use: as the diffuse component of natural sunlight and non-normal incidence of simulated sunlight interact with encapsulants and back sheets of a module and influence the amount of irradiance which a particular cell receives, it is recommended that reference devices used for measuring sub-assemblies of modules and arrays be encapsulated in a multi-cell package, matching the mechanical and optical features of the test specimen (module, sub-assemblies of modules, arrays) so as to respond to variations in the geometrical distribution of the incident radiation in the same way as the test specimen.

### 3.8

#### **single reference cell in a multi-cell package**

single photovoltaic cell mounted in such a package that frame, encapsulation system, shape, size and spacing of the cells surrounding it are the same as in the module to be tested

Note 1 to entry: The surrounding cells may be real or dummies that have the same optical properties.

### 3.9

#### **reference module**

photovoltaic module consisting of the encapsulation of a series and/or parallel connection of photovoltaic cells

Note 1 to entry: Recommended use: for measuring other modules in order to achieve correspondence of dimensions, mechanical construction, optical properties and electrical circuitry of the reference module and test module, so as to minimize discrepancies due to simulator non-uniformity, internal reflections or temperature distribution.

### 3.10 built-in shunt resistors

resistor connected across the output terminals of photovoltaic devices

Note 1 to entry: The resistor shunts the output of the photovoltaic device providing an output voltage to be measured and avoiding user-provided means of establishing short circuit condition.

## 4 Selection of reference device

### 4.1 General requirements

Depending on their intended use, reference devices need to meet different requirements in terms of their spectral responsivity, mechanical construction, optical properties, dimensions and electrical circuit. The spectral responsivity of the reference device, for example, is determined by the transmission of any protective cover in front of the device and the spectral responsivity of the device itself. Therefore the overall spectral responsivity can be adapted by using suitable filters as or in addition to the protective cover.

A reference device shall meet the following requirements:

- a) photovoltaic characteristics shall be stable according to the requirements in Clause 11;

- b) the output signal of the reference device shall vary linearly with irradiance, as defined in IEC 60904-10, over the range of interest.

**4.2 Additional requirements for single reference cell in a multi-cell package**

The dotted line in Figure 2 indicates the minimum acceptable size of a multi-cell package.

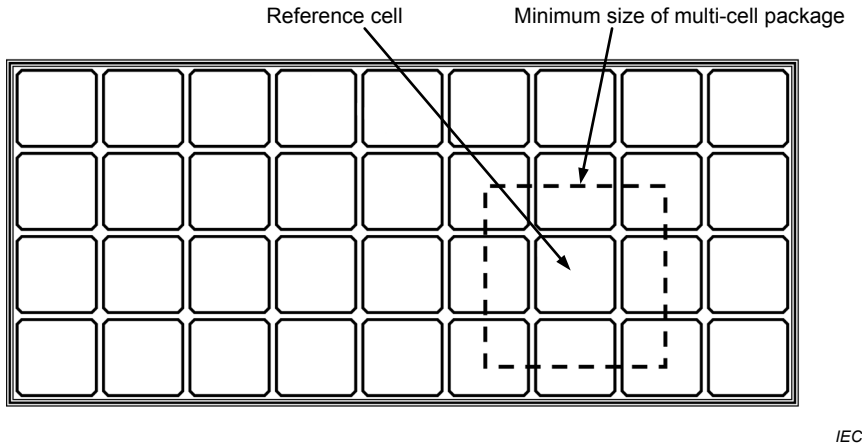

**Figure 2 – Single reference cell in a multi-cell package**

**4.3 Additional requirements for reference modules**

Additional requirements apply to reference modules:

- a) Bypass diodes:

- general reference modules, that are used to measure a range of module types and geometries, should not contain bypass diodes. The presence or absence of bypass diodes shall be noted and considered in conjunction with the measurement conditions, in particular spatial non-uniformity of the irradiance on the module during measurement;
- for reference modules, that are intended to be matched to the module under test, the number, type and connection of bypass diodes (if present) shall match those in the module under test.

- b) If they are made from discrete cells, these shall be matched as follows depending on the intended use of the reference module:

- if only the short circuit current of the reference module will be used the short circuit current of the individual cells shall be matched to within  $\pm 1\%$ ;
- if other parameters (such as maximum power) are used additionally or exclusively, both the short circuit current and the fill factor of the individual cells shall be matched to within  $\pm 1\%$ .

The matching of the individual cells is the responsibility of the manufacturer of the reference module, bearing in mind that matching may also be influenced by encapsulation or lamination. The cell matching needs not be checked by the calibration laboratory. However, if I-V curves of the reference module indicate inconsistent response (i.e. steps are noted in the I-V curve), the I-V curve should be measured under light that is known to be uniform (e.g. natural sunlight) to determine whether there is evidence that the cells within the module are matched within 1%. If the module exhibits evidence of  $> 1\%$  mismatch between cells, the module shall not be used as reference module.

**4.4 Requirements for built-in shunt resistors**

The resistor shall be chosen such as to ensure that the reference device operates sufficiently near to short-circuit condition, meeting the requirement:

$$I_{SC} \times R_{CAL} < 0,03 \times V_{OC} \quad (1)$$

where

$R_{CAL}$  is the shunt resistor;

$I_{SC}$  is the short circuit current of the reference device at reference conditions;

$V_{OC}$  is the open circuit voltage at reference conditions.

If a shunted reference cell does not meet the requirement of formula (1), it shall only be used at irradiances ( $\pm 5\%$ ) and temperatures ( $\pm 2\text{ °C}$ ) at which it was calibrated.

The long-term stability of such resistors shall also meet the stability requirements of the reference device. Calibration values of such reference devices shall be measured as the voltage drop across the shunt resistor and stated with the dimension [V] at standard test conditions (see Clause 7). The temperature coefficient of the built-in shunt resistor is part of the temperature coefficient of the calibration value of the reference device. As the uncertainty in the calibration may be strongly dependent on the shunt resistor stability and temperature coefficient, respective values should be provided with the reference cell data sheet.

If a shunted reference cell is to be used for low irradiance measurements, either a dedicated cell can be constructed with the restriction of formula (1), where the short circuit current is considered at the desired low irradiance rather than at STC. Alternatively a shunted cell can have a larger shunt resistor, but requires a separate calibration for each irradiance and temperature it is to be used at.

It is recommended that the shunt resistor be a removable 4-wire resistor, to allow for periodic checking of the reference device stability by taking an I-V curve per IEC 60904-1.

Formula (1) means that the measured output voltage of a shunted reference cell shall be less than 3 % of its open circuit voltage. For typical crystalline Silicon this equates to about 20 mV output.

<https://standards.iteh.ai/catalog/standards/sist/67af5b90-c267-4f44-8ad8-ce687514c434/iec-60904-2-2015>

## 5 Temperature measurement

Means shall be provided for determining the reference cell temperature or, for reference modules, the equivalent cell temperature (ECT), according to IEC 60904-5. The required uncertainty for temperature measurements shall be less than  $\pm 2,0\text{ °C}$  for all reference devices. A minimum accuracy of  $\pm 1,0\text{ °C}$  for the temperature sensor is suggested to achieve this uncertainty in the temperature measurement.

## 6 Electrical connections

The electrical connections to reference cells shall consist of a four-wire contact system (Kelvin probe). Care shall be taken to avoid measurement errors due to voltage drops along the cell's contact bars and the package wiring.

The electrical connections to the reference module shall be designed to meet the requirements of IEC 60904-1.

## 7 Calibration

Each reference device shall be calibrated in terms of its calibration value at the desired reference conditions, normally standard test conditions (STC) ( $1\,000\text{ W}\cdot\text{m}^{-2}$ ,  $25\text{ °C}$  device temperature with the reference spectral irradiance distribution as defined in IEC 60904-3).

Methods for calibrating primary reference devices are included in IEC 60904-4. A method of calibrating secondary reference devices is described in Clause 12. The calibration of working reference devices is treated in Clause 13.

The spectral responsivity at short-circuit current conditions of each reference device shall be measured in accordance with IEC 60904-8. If for reference modules this cannot be measured directly, it shall be deduced from measurements made on representative encapsulated photovoltaic cells.

The temperature coefficient of each reference device shall be measured in accordance with IEC 60891.

## 8 Report

Each time a reference device is calibrated, the following information shall be recorded on a data sheet:

- Identification number
- Type (primary reference cell; secondary reference device, working reference device)
- Cell manufacturer
- Material type
- Type of package
- Type and dimension of cell(s)
- Circuit diagram, in particular of any connectors
- Calibration organization
- Site and date of calibration
- Method of calibration (refer to standard)
- Radiometer or standard lamp characteristics (where applicable)
- Primary reference cell identification (where applicable)
- Simulator characteristics (where applicable)
- Type of temperature sensor (where applicable)
- Spectral responsivity
- Temperature coefficient of calibration value
- Calibration value at reference conditions
- Reference conditions
- Estimated uncertainty
- Shunt resistor nominal resistance and temperature coefficient (where applicable)
- Either the mismatch correction value used in the measurement or an estimate of the uncertainty introduced by using the mismatched reference device.

For reference cells without fixed electrical connection to the cell, the following information shall be recorded on the data sheet:

- Illustration of type, shape and location of electrical contacts during calibration.

For reference modules, the following information shall be recorded in addition on the data sheet:

- manufacturer
- model designation
- serial number