

SLOVENSKI STANDARD

SIST EN 60603-7-1:2010

01-januar-2010

BUXca Yý U
SIST EN 60603-7-1:2003

Konektorji za elektronsko opremo - 7-1. del: Podrobna specifikacije za 8-redne, zaslonjene, proste in fiksne konektorje (IEC 60603-7-1:2009)

Connectors for electronic equipment - Part 7-1: Detail specification for 8-way, shielded, free and fixed connectors (IEC 60603-7-1:2009)

Steckverbinder für elektronische Einrichtungen - Teil 7-1: Bauartspezifikation für geschirmte freie und feste Steckverbinder, 8polig (IEC 60603-7-1:2009)

Connecteurs pour équipements électroniques - Partie 7-1: Spécification particulière pour les fiches et les embases écrantées à 8 voies (CEI 60603-7-1:2009)

Ta slovenski standard je istoveten z: EN 60603-7-1:2009

ICS:

31.220.10 Xca 70 Ácã } 2VÁ [} ^\ q !lä Plug-and-socket devices.
Connectors

SIST EN 60603-7-1:2010

en,fr

iTeh STANDARD PREVIEW
(standards.iteh.ai)

[SIST EN 60603-7-1:2010](#)

<https://standards.iteh.ai/catalog/standards/sist/342ec6b6-6893-4ede-b586-bdb50cc92e3/sist-en-60603-7-1-2010>

EUROPEAN STANDARD
NORME EUROPÉENNE
EUROPÄISCHE NORM

EN 60603-7-1

November 2009

ICS 31.220.10

Supersedes EN 60603-7-1:2002

English version

**Connectors for electronic equipment -
Part 7-1: Detail specification for 8-way, shielded, free and fixed connectors
(IEC 60603-7-1:2009)**

Connecteurs pour équipements
électroniques -
Partie 7-1: Spécification particulière
pour les fiches et les embases blindées
à 8 voies
(CEI 60603-7-1:2009)

Steckverbinder für elektronische
Einrichtungen -
Teil 7-1: Bauartspezifikation
für geschirmte freie und feste
Steckverbinder, 8polig
(IEC 60603-7-1:2009)

iTeh STANDARD PREVIEW
(standards.iteh.ai)

This European Standard was approved by CENELEC on 2009-09-01. CENELEC members are bound to comply with the CEN/CENELEC Internal Regulations which stipulate the conditions for giving this European Standard the status of a national standard without any alteration.

Up-to-date lists and bibliographical references concerning such national standards may be obtained on application to the Central Secretariat or to any CENELEC member.

This European Standard exists in three official versions (English, French, German). A version in any other language made by translation under the responsibility of a CENELEC member into its own language and notified to the Central Secretariat has the same status as the official versions.

CENELEC members are the national electrotechnical committees of Austria, Belgium, Bulgaria, Cyprus, the Czech Republic, Denmark, Estonia, Finland, France, Germany, Greece, Hungary, Iceland, Ireland, Italy, Latvia, Lithuania, Luxembourg, Malta, the Netherlands, Norway, Poland, Portugal, Romania, Slovakia, Slovenia, Spain, Sweden, Switzerland and the United Kingdom.

CENELEC

European Committee for Electrotechnical Standardization
Comité Européen de Normalisation Electrotechnique
Europäisches Komitee für Elektrotechnische Normung

Central Secretariat: Avenue Marnix 17, B - 1000 Brussels

Foreword

The text of document 48B/2004/FDIS, future edition 2 of IEC 60603-7-1, prepared by SC 48B, Connectors, of IEC TC 48, Electromechanical components and mechanical structures for electronic equipment, was submitted to the IEC-CENELEC parallel vote and was approved by CENELEC as EN 60603-7-1 on 2009-09-01

This European Standard supersedes EN 60603-7-1:2002.

EN 60603-7-1:2009 includes the following significant technical changes with respect to EN 60603-7-1:2002:

- the basic connector dimensions were removed from EN 60603-7-1:2002 and referenced to EN 60603-7;
- several other subclauses were removed (e.g. 4.1, 5, 6.1, 6.2) from EN 60603-7-1:2002 and referenced to EN 60603-7;
- the electrical characteristics, Subclause 6.4, were revised;
- the test schedules were revised.

The following dates were fixed:

- latest date by which the EN has to be implemented at national level by publication of an identical national standard or by endorsement (dop) 2010-06-01
- latest date by which the national standards conflicting with the EN have to be withdrawn (dow) 2012-09-01

Annex ZA has been added by CENELEC. <http://www.cenelec.eu/catalog/standards/sist/342ec6b6-6893-4ede-b586-bdb50cc92eB/sist-en-60603-7-1-2010>

Endorsement notice

The text of the International Standard IEC 60603-7-1:2009 was approved by CENELEC as a European Standard without any modification.

Annex ZA (normative)

Normative references to international publications with their corresponding European publications

The following referenced documents are indispensable for the application of this document. For dated references, only the edition cited applies. For undated references, the latest edition of the referenced document (including any amendments) applies.

NOTE When an international publication has been modified by common modifications, indicated by (mod), the relevant EN/HD applies.

<u>Publication</u>	<u>Year</u>	<u>Title</u>	<u>EN/HD</u>	<u>Year</u>
-	-	Communication cables - Specifications for test methods - Part 1-14: Electrical test methods - Coupling attenuation or screening attenuation of connecting hardware	EN 50289-1-14	- ¹⁾
IEC 60068-2-38	- ¹⁾	Environmental testing - Part 2-38: Tests - Test Z/AD: Composite temperature/humidity cyclic test	EN 60068-2-38	2009
IEC 60512	Series	Connectors for electronic equipment - Tests and measurements	EN 60512	Series
IEC 60512-1-100	- ¹⁾	Connectors for electronic equipment - Tests and measurements - Part 1-100: General - Applicable publications	EN 60512-1-100	2006 ²⁾
IEC 60603-7	Series	Connectors for electronic equipment - Part 7: Detail specifications for 8-way free and fixed connectors	EN 60603-7	Series
IEC 60603-7	2008	Connectors for electronic equipment - Part 7: Detail specification for 8-way, unshielded, free and fixed connectors	EN 60603-7	2009
IEC 60664-1	- ¹⁾	Insulation coordination for equipment within low-voltage systems - Part 1: Principles, requirements and tests	EN 60664-1	2007 ²⁾
IEC 61156-5	- ¹⁾	Multicore and symmetrical pair/quad cables for digital communications - Part 5: Symmetrical pair/quad cables with transmission characteristics up to 1 000 MHz - Horizontal floor wiring - Sectional specification	-	-
ISO 1302	- ¹⁾	Geometrical Product Specifications (GPS) - Indication of surface texture in technical product documentation	EN ISO 1302	2002 ²⁾

¹⁾ Undated reference.

²⁾ Valid edition at date of issue.

iTeh STANDARD PREVIEW
(standards.iteh.ai)

[SIST EN 60603-7-1:2010](#)

<https://standards.iteh.ai/catalog/standards/sist/342ec6b6-6893-4ede-b586-bdb50cc92e3/sist-en-60603-7-1-2010>



IEC 60603-7-1

Edition 2.0 2009-06

INTERNATIONAL STANDARD

NORME INTERNATIONALE

**Connectors for electronic equipment –
Part 7-1: Detail specification for 8-way, shielded, free and fixed connectors**

**Connecteurs pour équipements électroniques –
Partie 7-1: Spécification particulière pour les fiches et les embases blindés à
8 voies**

INTERNATIONAL
ELECTROTECHNICAL
COMMISSION

COMMISSION
ELECTROTECHNIQUE
INTERNATIONALE

PRICE CODE
CODE PRIX

T

ICS 31.220.10

ISBN 2-8318-1041-9

CONTENTS

FOREWORD.....	4
INTRODUCTION.....	6
1 General.....	7
2 Terms and definitions.....	7
3 Common features and isometric view.....	8
3.1 Isometric view.....	8
3.2 Mating information.....	8
3.2.1 General.....	8
3.2.2 Fixed connector.....	9
3.2.3 Free connector.....	10
4 Cable terminations and internal connections – Fixed and free connectors.....	11
4.1 Internal connections.....	11
4.2 Cable termination.....	11
5 Gauges.....	11
6 Characteristics.....	11
6.1 General.....	11
6.2 Pin and pair grouping assignment.....	11
6.3 Classification into climatic category.....	11
6.4 Electrical characteristics.....	12
6.4.1 Creepage and clearance distances.....	12
6.4.2 Voltage proof.....	12
6.4.3 Current-carrying capacity.....	12
6.4.4 Initial contact resistance – interface only (between separable fixed and free connectors).....	12
6.4.5 Input to output d.c. resistance.....	12
6.4.6 Initial insulation resistance.....	13
6.4.7 Transfer impedance.....	13
6.4.8 Coupling attenuation.....	13
6.5 Mechanical.....	13
6.5.1 Mechanical operation.....	13
6.5.2 Insertion and withdrawal forces.....	13
7 Tests and test schedule.....	13
7.1 General.....	13
7.2 Arrangement for contact resistance tests.....	14
7.3 Arrangement for vibration tests.....	14
7.4 Test procedures and measuring methods.....	14
7.5 Preconditioning.....	14
7.6 Wiring and mounting of specimens.....	14
7.6.1 Wiring.....	14
7.6.2 Mounting.....	14
7.7 Test schedules.....	14
7.7.1 Basic (minimum) test schedule.....	14
7.7.2 Full test schedule.....	14
Annex A (normative) Gauging continuity test.....	21
Bibliography.....	25

Figure 1 – IEC 60603-7 document structure	6
Figure 2 – Isometric view	8
Figure 3 – Fixed connector details	9
Figure 4 – Free connector view	10
Figure A.1 – Gauge.....	23
Figure A.2 – Gauge insertion	24
Table 1 – Dimensions for Figure 3	10
Table 2 – Dimensions for Figure 4	11
Table 3 – Creepage and clearance distances.....	12
Table 4 – Test group P	15
Table 5 – Test group AP	16
Table 6 – Test group BP	17
Table 7 – Test group CP	18
Table 8 – Test group DP	19
Table 9 – Test group GP.....	20
Table A.1 – Dimensions for Figure A.1.....	22

iTeh STANDARD PREVIEW
(standards.iteh.ai)

[SIST EN 60603-7-1:2010](https://standards.iteh.ai/catalog/standards/sist/342ec6b6-6893-4ede-b586-bdb50cc92e3/sist-en-60603-7-1-2010)

<https://standards.iteh.ai/catalog/standards/sist/342ec6b6-6893-4ede-b586-bdb50cc92e3/sist-en-60603-7-1-2010>

INTERNATIONAL ELECTROTECHNICAL COMMISSION

CONNECTORS FOR ELECTRONIC EQUIPMENT –**Part 7-1: Detail specification for 8-way, shielded,
free and fixed connectors**

FOREWORD

- 1) The International Electrotechnical Commission (IEC) is a worldwide organization for standardization comprising all national electrotechnical committees (IEC National Committees). The object of IEC is to promote international co-operation on all questions concerning standardization in the electrical and electronic fields. To this end and in addition to other activities, IEC publishes International Standards, Technical Specifications, Technical Reports, Publicly Available Specifications (PAS) and Guides (hereafter referred to as "IEC Publication(s)"). Their preparation is entrusted to technical committees; any IEC National Committee interested in the subject dealt with may participate in this preparatory work. International, governmental and non-governmental organizations liaising with the IEC also participate in this preparation. IEC collaborates closely with the International Organization for Standardization (ISO) in accordance with conditions determined by agreement between the two organizations.
- 2) The formal decisions or agreements of IEC on technical matters express, as nearly as possible, an international consensus of opinion on the relevant subjects since each technical committee has representation from all interested IEC National Committees.
- 3) IEC Publications have the form of recommendations for international use and are accepted by IEC National Committees in that sense. While all reasonable efforts are made to ensure that the technical content of IEC Publications is accurate, IEC cannot be held responsible for the way in which they are used or for any misinterpretation by any end user.
- 4) In order to promote international uniformity, IEC National Committees undertake to apply IEC Publications transparently to the maximum extent possible in their national and regional publications. Any divergence between any IEC Publication and the corresponding national or regional publication shall be clearly indicated in the latter.
<https://standards.iteh.ai/catalog/standards/sist/342ec6b6-6893-4ede-b586-7bb9-2c3181499371/iec-60603-7-1-2010>
- 5) IEC provides no marking procedure to indicate its approval and cannot be rendered responsible for any equipment declared to be in conformity with an IEC Publication.
- 6) All users should ensure that they have the latest edition of this publication.
- 7) No liability shall attach to IEC or its directors, employees, servants or agents including individual experts and members of its technical committees and IEC National Committees for any personal injury, property damage or other damage of any nature whatsoever, whether direct or indirect, or for costs (including legal fees) and expenses arising out of the publication, use of, or reliance upon, this IEC Publication or any other IEC Publications.
- 8) Attention is drawn to the Normative references cited in this publication. Use of the referenced publications is indispensable for the correct application of this publication.
- 9) Attention is drawn to the possibility that some of the elements of this IEC Publication may be the subject of patent rights. IEC shall not be held responsible for identifying any or all such patent rights.

International Standard IEC 60603-7-1 has been prepared by subcommittee 48B: Connectors, of IEC technical committee 48: Electromechanical components and mechanical structures for electronic equipment.

This second edition cancels and replaces the first edition published in 2002. This edition constitutes a technical revision.

This edition included the following significant technical changes with respect to the previous edition:

- 1) The basic connector dimensions were removed from the edition 1 standard and referenced to IEC 60603-7.
- 2) Several other subclauses were removed (e.g. 4.1, 5, 6.1, 6.2) from the edition 1 standard and referenced to IEC 60603-7.
- 3) The electrical characteristics, subclause 6.4, was revised.
- 4) The test schedules were revised.

The text of this standard is based on the following documents:

FDIS	Report on voting
48B/2004/FDIS	48B/2038/RVD

Full information on the voting for the approval of this standard can be found in the report on voting indicated in the above table.

This publication has been drafted in accordance with the ISO/IEC Directives, Part 2.

A list of all parts of the IEC 60603 series, under the general title *Connectors for electronic equipment*, can be found on the IEC website.

The committee has decided that the contents of this publication will remain unchanged until the maintenance result date indicated on the IEC web site under "<http://webstore.iec.ch>" in the data related to the specific publication. At this date, the publication will be

- reconfirmed,
- withdrawn,
- replaced by a revised edition, or
- amended.

iTeh STANDARD PREVIEW (standards.iteh.ai)

[SIST EN 60603-7-1:2010](#)

<https://standards.iteh.ai/catalog/standards/sist/342ec6b6-6893-4ede-b586-bdb50cc92e3/sist-en-60603-7-1-2010>

INTRODUCTION

Applications have emerged which require the use of the interface described in IEC 60603-7 with certain performance specifications at higher frequencies. Therefore, a series of detail specifications have been issued the past few years in support of these new applications. In order to improve readability and ease of maintenance, IEC Subcommittee 48B (SC 48B) decided to rearrange and restructure these existing documents.

This part of IEC 60603-7 contains only the necessary information regarding the shield of the connection and is designed to be used as a base document for all shielded connectors in the IEC 60603-7 series.

For further information regarding the IEC 60603-7 style connection, reference to the unshielded base document IEC 60603-7 is made.

IEC 60603-7 is the base specification of the whole series. Subsequent specifications do not duplicate information given in the base document, but list only additional requirements. For a complete specification regarding a component of a higher number document, all lower numbered documents are also to be considered.

The following illustration shows the IEC 60603-7 document structure:

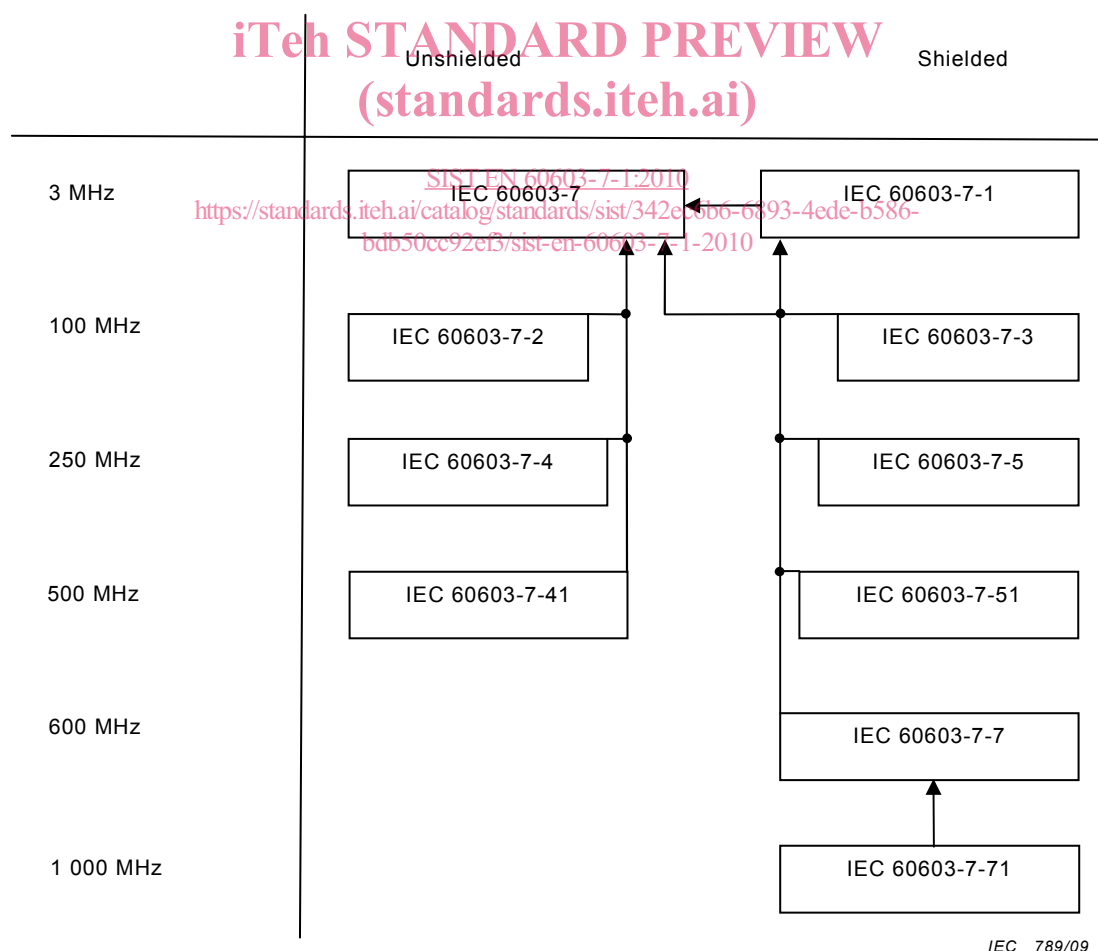

Figure 1 – IEC 60603-7 document structure