; YchM b] bc`dfY]g_cj Ub`Y]b`dfYg_i ýUb`Y`È`DfYg_i ýUb`Y`bUHfYbi `È' "XY.
GHubXUfXb]`dYbYffUW]g_]`dfYg_i g`fIGC`&& (+*!' .&\$) Ł

Geotechnical investigation and testing - Field testing - Part 3: Standard penetration test
(ISO 22476-3:2005)

Geotechnische Erkundung und Untersuchung - Felduntersuchungen - Teil 3: Standard
Penetration Test (ISO 22476-3:2005)

Reconnaissance et essais géotechniques - Essais en place - Partie 3 : Essais de
pénétration au carottier (ISO 22476-3:2005)

[https://standards.iteh.ai/catalog/standards/sist/1d29dc56-12fc-4a07-8d44-
b7df2e42a91/sist-en-iso-22476-3-2005](https://standards.iteh.ai/catalog/standards/sist/1d29dc56-12fc-4a07-8d44-b7df2e42a91/sist-en-iso-22476-3-2005)

Ta slovenski standard je istoveten z: EN ISO 22476-3:2005

ICS:

93.020	Zemeljska dela. Izkopavanja.	Earthworks. Excavations.
	Gradnja temeljev. Dela pod	Foundation construction.
	zemljo	Underground works

SIST EN ISO 22476-3:2005

en

iTeh STANDARD PREVIEW
(standards.iteh.ai)

SIST EN ISO 22476-3:2005

<https://standards.iteh.ai/catalog/standards/sist/1d29dc56-12fc-4a07-8d44-b7df2e4f2a91/sist-en-iso-22476-3-2005>

ICS 93.020

English version

Geotechnical investigation and testing - Field testing - Part 3:
Standard penetration test (ISO 22476-3:2005)

Reconnaissance et essais géotechniques - Essais en place
- Partie 3 : Essais de pénétration au carottier (ISO 22476-
3:2005)

Geotechnische Erkundung und Untersuchung -
Felduntersuchungen - Teil 3: Standard penetration test
(ISO 22476-3:2005)

This European Standard was approved by CEN on 4 November 2004.

CEN members are bound to comply with the CEN/CENELEC Internal Regulations which stipulate the conditions for giving this European Standard the status of a national standard without any alteration. Up-to-date lists and bibliographical references concerning such national standards may be obtained on application to the Central Secretariat or to any CEN member.

This European Standard exists in three official versions (English, French, German). A version in any other language made by translation under the responsibility of a CEN member into its own language and notified to the Central Secretariat has the same status as the official versions.

CEN members are the national standards bodies of Austria, Belgium, Cyprus, Czech Republic, Denmark, Estonia, Finland, France, Germany, Greece, Hungary, Iceland, Ireland, Italy, Latvia, Lithuania, Luxembourg, Malta, Netherlands, Norway, Poland, Portugal, Slovakia, Slovenia, Spain, Sweden, Switzerland and United Kingdom.

[SIST EN ISO 22476-3:2005](https://standards.iteh.ai/catalog/standards/sist/1d29dc56-12fc-4a07-8d44-b7df2e42a91/sist-en-iso-22476-3-2005)

<https://standards.iteh.ai/catalog/standards/sist/1d29dc56-12fc-4a07-8d44-b7df2e42a91/sist-en-iso-22476-3-2005>



EUROPEAN COMMITTEE FOR STANDARDIZATION
COMITÉ EUROPÉEN DE NORMALISATION
EUROPÄISCHES KOMITEE FÜR NORMUNG

Management Centre: rue de Stassart, 36 B-1050 Brussels

Contents

	page
Foreword.....	3
1 Scope	4
2 Normative references	4
3 Terms and definitions	4
4 Equipment	5
5 Test Procedure.....	7
6 Test results	8
7 Reporting	8
Annex A (informative) Correction factors	11
A.1 Energy delivered to the drive rods.....	11
A.2 Energy losses due to the length of rods.....	11
A.3 Other correction factors.....	11
A.4 Effect of overburden pressure in sands.....	12
A.5 Use of the correction factors.....	12
Annex B (informative) Recommended method to measure the actual energy	14
B.1 Principle.....	14
B.2 Equipment	14
B.3 Measurements.....	14
B.4 Calculation.....	15
Bibliography.....	17

Foreword

This document (EN ISO 22476-3:2005) has been prepared by Technical Committee CEN/TC 341 "Geotechnical investigation and testing", the secretariat of which is held by DIN, in collaboration with Technical Committee ISO/TC 182 "Geotechnics".

This European Standard shall be given the status of a national standard, either by publication of an identical text or by endorsement, at the latest by July 2005, and conflicting national standards shall be withdrawn at the latest by July 2005.

EN ISO 22476 *Geotechnical investigation and testing - Field testing* has the following parts:

— *Part 1: Electrical cone and piezocone penetration tests*

— *Part 2: Dynamic probing*

— *Part 3: Standard penetration test*

— *Part 4: Menard pressuremeter test*

— *Part 5: Flexible dilatometer test*

— *Part 6: Self-boring pressuremeter test*

— *Part 7: Borehole jack test*

— *Part 8: Full displacement pressuremeter test*

— *Part 9: Field vane test*

— *Part 10: Weight sounding test*

— *Part 11: Flat dilatometer test*

— *Part 12: Lefranc permeability test*

— *Part 13: Water pressure tests in rock*

According to the CEN/CENELEC Internal Regulations, the national standards organizations of the following countries are bound to implement this European Standard : Austria, Belgium, Cyprus, Czech Republic, Denmark, Estonia, Finland, France, Germany, Greece, Hungary, Iceland, Ireland, Italy, Latvia, Lithuania, Luxembourg, Malta, Netherlands, Norway, Poland, Portugal, Slovakia, Slovenia, Spain, Sweden, Switzerland and United Kingdom.

ITeh STANDARD PREVIEW
(standards.iteh.ai)

[SIST EN ISO 22476-3:2005](https://standards.iteh.ai/catalog/standards/sist/1d29dc56-12fc-4a07-8d44-11/sist-en-iso-22476-3-2005)

[https://standards.iteh.ai/catalog/standards/sist/1d29dc56-12fc-4a07-8d44-](https://standards.iteh.ai/catalog/standards/sist/1d29dc56-12fc-4a07-8d44-11/sist-en-iso-22476-3-2005)

[11/sist-en-iso-22476-3-2005](https://standards.iteh.ai/catalog/standards/sist/1d29dc56-12fc-4a07-8d44-11/sist-en-iso-22476-3-2005)

1 Scope

This document specifies requirements for indirect investigations of soil by standard penetration test as part of geotechnical investigation and testing according to EN 1997-1 and EN 1997-2 to compliment direct investigations (e.g. sampling according to prEN ISO 22475-1).

The standard penetration test aims to determine the resistance of soils at the base of a borehole to the dynamic penetration of a split barrel sampler and the recovering of disturbed samples for identification purposes (SPT). In gravelly soils and in soft rocks a solid cone is also be used (SPT(C)).

The standard penetration test is used mainly to assess the strength and deformation parameters of cohesionless soils, but some valuable data may also be obtained in other soil types.

The basis of the test consists in driving a sampler by dropping a hammer of 63,5 kg mass on to an anvil or drive head from a height of 760 mm. The number of blows (N) necessary to achieve a penetration of the sampler of 300 mm (after its penetration under gravity and below a seating drive) is the penetration resistance.

2 Normative references

The following referenced documents are indispensable for the application of this document. For dated references, only the edition cited applies. For undated references, the latest edition of the referenced document (including any amendments) applies.

prEN ISO 22475-1, *Geotechnical investigation and testing — Sampling by drilling and excavation methods and groundwater measurements — Part 1: Technical principles for execution (ISO/DIS 22475-1:2004)*

3 Terms and definitions

<https://standards.itech.ai/catalog/standards/sist/1d29dc56-12fc-4a07-8d44-b7df2e4f2a91/sist-en-iso-22476-3-2005>

For the purposes of this document, the following terms and definitions apply.

3.1

anvil or drive head

that portion of the drive-weight assembly that the hammer strikes and through which the hammer energy passes into the drive rods

3.2

hammer

portion of the drive-weight assembly consisting of the 63,5 kg impact weight which is successively lifted and dropped to provide the energy that accomplishes the penetration and sampling

3.3

height of fall

free fall of the hammer after being released

3.4

drive-weight assembly

device consisting of the hammer, the hammer fall guide, the anvil and the drop system

3.5

drive rods

rods that connect the drive-weight assembly to the sampler

3.6

actual energy

E_{meas}

energy delivered by the drive-weight assembly into the drive rod, immediately below the anvil, as measured

3.7 theoretical energy

E_{theor}
energy as calculated for the drive weight assembly:

$$E_{\text{theor}} = m \times g \times h$$

where

- m is the mass of the hammer;
- g is the acceleration due to gravity;
- h is the falling height of the hammer.

3.8 energy ratio

E_r
ratio of the actual energy E_{meas} and the theoretical energy E_{theor} of the hammer expressed in percentage

3.9 N-value

number of blows required to drive the sampler for a test drive of 300 mm following the seating drive

4 Equipment

iTeh STANDARD PREVIEW
(standards.iteh.ai)

4.1 Drilling equipment

The drilling equipment shall be capable of providing a clean hole to ensure that the penetration test is performed on essentially undisturbed soil.

The area that is exposed in the base of the borehole prior to testing can influence the results and consequently the borehole diameter shall always be reported. A significant effect on the result can begin to occur when the diameter is 150 mm or more.

4.2 Sampler

The steel split barrel sampler shall have the dimensions indicated in Figure 1 and shall be provided with a non-return valve with sufficient clearance to permit the free flow of water or mud during driving.

The inner diameter of the sampler can be up to 3 mm larger than that of the shoe to allow for a liner. In gravelly sand, a solid 60° cone instead of the standard shoe can be used. In this case the test shall be noted as SPT(C).

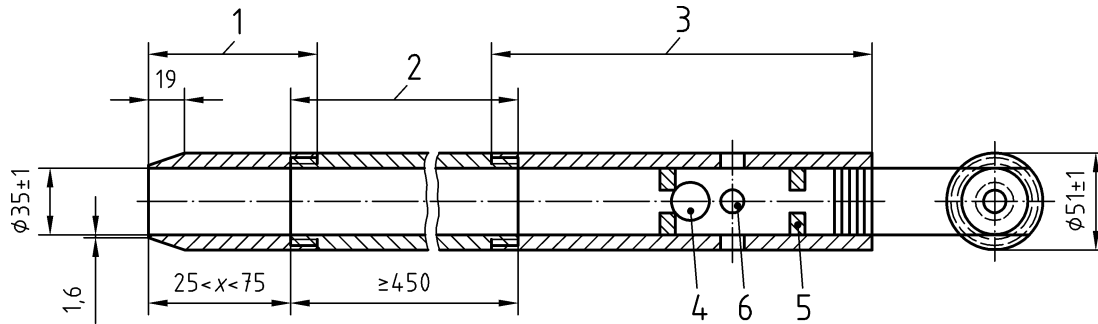

Key

- 1 Drive shoe
- 2 Split barrel
- 3 Coupling
- 4 Non return valve (ball diameter: recommended 25 mm; ball seating: recommended 22 mm)
- 5 Ball retaining pins
- 6 Four vent holes (min diameter 12 mm)
- x Length of the drive shoe

Figure 1 — Longitudinal cross section of an SPT sampler without a provision for a liner (dimensions in mm)

4.3 Drive rods

iTeh STANDARD PREVIEW

The drive rods shall have a stiffness that prevents buckling during driving. Rods with a mass of more than 10,0 kg/m shall not be used. Only straight rods shall be used and periodic checks shall be made on site, including connections between consecutive rods. When measured over the whole length of each rod the relative deflection shall not be greater than 1 in 1 200.

<https://standards.iteh.ai/catalog/standards/sist/1d29dc56-12fc-4a07-8d44-b7df2e42a91/sist-en-iso-22476-3-2005>

4.4 Drive weight assembly

The drive weight assembly, of an overall mass not exceeding 115 kg, shall comprise:

- a steel hammer of 63,5 kg ± 0,5 kg conveniently guided to ensure minimal resistance during the drop;
- an automatic release mechanism which will ensure a constant free fall of (760 ± 10) mm, a negligible speed of the hammer when released, and no induced parasitic movements in the drive rods;
- a steel drive head or anvil rigidly connected to the top of the drive rods. It may be an internal part of the assembly, as with safety hammers.

4.5 Optional equipment

4.5.1 Blow counter

A device to measure mechanical or electric impulses can be placed on the system in order to count the number of the blows of hammer.

4.5.2 Penetration length measuring device

The penetration length is measured either by counting on a scale on the rods or by recording sensors. In this latter case, resolution shall be less than 1/100 of the measured length.

5 Test Procedure

5.1 Equipment checks and calibration

Prior to each test series, the sampler shall be checked to ensure that it is in proper condition (dimensions). The straightness of the rods shall be checked once on each new site and at least every 20 penetration tests at that site. After each test, a visual check of the straightness of the rods shall be made.

At the test site, the height of fall, the friction free fall of the hammer, the proper condition of the anvil and the mechanical release devices shall be checked for satisfactory operation which is to be ensured for the whole test series. In addition, the proper functioning of the recording device shall be checked when automatic recording equipment is used.

The precision of the measuring instruments – if applicable – shall be checked after any damage, overloading or repair but at least once every six months, unless the manufacturer's manual requires shorter inspection intervals. Faulty parts shall be replaced. Calibration records shall be kept together with the equipment.

Energy losses occur e.g. due to friction at the hammer (velocity loss compared to the free fall) or due to energy losses during the hammer impact on the anvil. Therefore, the energy ratio E_r of the equipment used has to be known if the N-values are going to be used for the quantitative evaluation of foundations or for the comparisons of results. A certificate of calibration of the E_r -value immediately below the driving head or anvil shall be available.

NOTE A recommended method to determine the actual energy is given in Annex B.

5.2 Preparation of the borehole

The borehole shall be prepared for the specified test depth. The base of the borehole shall be clean and essentially undisturbed at the test elevation and without an upward water pressure gradient.

When drilling bits are used, they shall be provided with side discharge and not with bottom discharge, from a safe distance of the test elevation.

When testing below the groundwater table, particular care shall be taken to avoid any entry of water through the bottom of the borehole, as this will tend to loosen the soil or even lead to piping. For this purpose, the level of the water or drilling fluid in the borehole shall be maintained at a sufficient level above the groundwater level in the layer with the highest pressure (potential) at all times, even during withdrawal of the boring tools. Withdrawal shall be performed slowly and with drilling tools providing enough clearance to prevent suction effects at the bottom.

When a casing is used, it shall not be driven below the level at which the test will start.

5.3 Test execution

The sampler and the drive rods shall be lowered to the bottom of the borehole and then the hammer assembly added. The initial penetration shall be recorded. The sampler shall be penetrated over an initial or seating drive of 150 mm applying the 63,5 kg hammer free falling 760 mm and the number of blows N_0 shall be recorded. Then the sampler in the same manner shall be driven over a test drive of 300 mm in at least 2 increments of 150 mm. The number of blows needed, shall be recorded during each of these increments (N_n). If a total of 50 blows for the test drive is reached, the test may be finished ($N = 50$); in soft rocks it can be increased to 100 blows ($N = 100$). The total number of blows required for the 300 mm penetration after the seating drive is termed the penetration resistance of that soil layer ($N = N_n + N_{n+1}$).

In hard soils or in soft rocks where the penetration resistance is very high, the penetration for a certain number of blows may be recorded.

If the sampler advances below the bottom of the borehole under the static weight of the drive rods and hammer assembly on top, the corresponding penetration shall not be included, as seating drive and this information should be reported. In no case shall any material reach the level of the non return valve.

Samples recovered shall be recorded and handled in accordance with prEN ISO 22475-1.