

INTERNATIONAL STANDARD

NORME INTERNATIONALE

Miniature fuses – **STANDARD PREVIEW**
Part 7: Miniature fuse-links for special applications
(standards.iteh.ai)

Coupe-circuit miniatures –
Partie 7: Éléments de remplacement miniatures pour applications spéciales

IEC 60127-7:2015
<https://standards.iteh.ai/catalog/standards/sist/c561a160-cc78-415d-97dc-bb4ee4eda9ad/iec-60127-7-2015>





THIS PUBLICATION IS COPYRIGHT PROTECTED

Copyright © 2015 IEC, Geneva, Switzerland

All rights reserved. Unless otherwise specified, no part of this publication may be reproduced or utilized in any form or by any means, electronic or mechanical, including photocopying and microfilm, without permission in writing from either IEC or IEC's member National Committee in the country of the requester. If you have any questions about IEC copyright or have an enquiry about obtaining additional rights to this publication, please contact the address below or your local IEC member National Committee for further information.

Droits de reproduction réservés. Sauf indication contraire, aucune partie de cette publication ne peut être reproduite ni utilisée sous quelque forme que ce soit et par aucun procédé, électronique ou mécanique, y compris la photocopie et les microfilms, sans l'accord écrit de l'IEC ou du Comité national de l'IEC du pays du demandeur. Si vous avez des questions sur le copyright de l'IEC ou si vous désirez obtenir des droits supplémentaires sur cette publication, utilisez les coordonnées ci-après ou contactez le Comité national de l'IEC de votre pays de résidence.

IEC Central Office
3, rue de Varembe
CH-1211 Geneva 20
Switzerland

Tel.: +41 22 919 02 11
info@iec.ch
www.iec.ch

About the IEC

The International Electrotechnical Commission (IEC) is the leading global organization that prepares and publishes International Standards for all electrical, electronic and related technologies.

About IEC publications

The technical content of IEC publications is kept under constant review by the IEC. Please make sure that you have the latest edition, a corrigenda or an amendment might have been published.

IEC Catalogue - webstore.iec.ch/catalogue

The stand-alone application for consulting the entire bibliographical information on IEC International Standards, Technical Specifications, Technical Reports and other documents. Available for PC, Mac OS, Android Tablets and iPad.

IEC publications search - webstore.iec.ch/advsearchform

The advanced search enables to find IEC publications by a variety of criteria (reference number, text, technical committee,...). It also gives information on projects, replaced and withdrawn publications.

IEC Just Published - webstore.iec.ch/justpublished

Stay up to date on all new IEC publications. Just Published details all new publications released. Available online and also once a month by email.

Electropedia - www.electropedia.org

The world's leading online dictionary of electronic and electrical terms, containing 21 000 terms and definitions in English and French, with equivalent terms in 16 additional languages. Also known as the International Electrotechnical Vocabulary (IEV) online.

IEC Glossary - std.iec.ch/glossary

67 000 electrotechnical terminology entries in English and French extracted from the Terms and Definitions clause of IEC publications issued since 2002. Some entries have been collected from earlier publications of IEC TC 37, 77, 86 and CISPR.

IEC Customer Service Centre - webstore.iec.ch/csc

If you wish to give us your feedback on this publication or need further assistance, please contact the Customer Service Centre: sales@iec.ch.

A propos de l'IEC

La Commission Electrotechnique Internationale (IEC) est la première organisation mondiale qui élabore et publie des Normes internationales pour tout ce qui a trait à l'électricité, à l'électronique et aux technologies apparentées.

A propos des publications IEC

Le contenu technique des publications IEC est constamment revu. Veuillez vous assurer que vous possédez l'édition la plus récente, un corrigendum ou amendement peut avoir été publié.

Catalogue IEC - webstore.iec.ch/catalogue

Application autonome pour consulter tous les renseignements bibliographiques sur les Normes internationales, Spécifications techniques, Rapports techniques et autres documents de l'IEC. Disponible pour PC, Mac OS, tablettes Android et iPad.

Recherche de publications IEC - webstore.iec.ch/advsearchform

La recherche avancée permet de trouver des publications IEC en utilisant différents critères (numéro de référence, texte, comité d'études,...). Elle donne aussi des informations sur les projets et les publications remplacées ou retirées.

IEC Just Published - webstore.iec.ch/justpublished

Restez informé sur les nouvelles publications IEC. Just Published détaille les nouvelles publications parues. Disponible en ligne et aussi une fois par mois par email.

Electropedia - www.electropedia.org

Le premier dictionnaire en ligne de termes électroniques et électriques. Il contient 21 000 termes et définitions en anglais et en français, ainsi que les termes équivalents dans 16 langues additionnelles. Egalement appelé Vocabulaire Electrotechnique International (IEV) en ligne.

Glossaire IEC - std.iec.ch/glossary

67 000 entrées terminologiques électrotechniques, en anglais et en français, extraites des articles Termes et Définitions des publications IEC parues depuis 2002. Plus certaines entrées antérieures extraites des publications des CE 37, 77, 86 et CISPR de l'IEC.

Service Clients - webstore.iec.ch/csc

Si vous désirez nous donner des commentaires sur cette publication ou si vous avez des questions contactez-nous: sales@iec.ch.

INTERNATIONAL STANDARD

NORME INTERNATIONALE

Miniature fuses – iTeh STANDARD PREVIEW
Part 7: Miniature fuse-links for special applications
(standards.iteh.ai)

Coupe-circuit miniatures – IEC 60127-7:2015
Partie 7: Éléments de remplacement miniatures pour applications spéciales
bb4ee4eda9ad/iec-60127-7-2015

INTERNATIONAL
ELECTROTECHNICAL
COMMISSION

COMMISSION
ELECTROTECHNIQUE
INTERNATIONALE

ICS 29.120.50

ISBN 978-2-8322-5506-3

Warning! Make sure that you obtained this publication from an authorized distributor.
Attention! Veuillez vous assurer que vous avez obtenu cette publication via un distributeur agréé.

CONTENTS

FOREWORD	3
INTRODUCTION	5
1 Scope	6
2 Normative references	6
3 Terms and definitions	7
4 General requirements	8
5 Standard ratings	8
6 Marking	8
7 General notes on tests	9
8 Dimensions and construction	14
9 Electrical requirements	15
10 Standard sheets	25
Annex A (informative) Guidance on ratings to be specified by the manufacturer or to be agreed upon with the testing house	28
Bibliography	29
Figure 1 – Standard test board for fuse-links with wire terminations	11
Figure 2 – Test board for surface mount fuse-links	12
Figure 3 – Test fuse base	13
Figure 4 – Test circuits for breaking capacity tests	16
Table 1 – Power factor and time constant	17
Table 2 – Testing schedule for individual ampere ratings for a.c. or d.c. breaking capacity fuse-links	20
Table 3 – Testing schedule for individual ampere ratings for a.c. and d.c. breaking capacity fuse-links	21
Table 4 – Testing schedule for maximum ampere rating of a homogeneous series (a.c. or d.c. breaking capacity fuse-links)	22
Table 5 – Testing schedule for maximum ampere rating of a homogeneous series (a.c. and d.c. breaking capacity fuse-links)	23
Table 6 – Testing schedule for minimum ampere rating of a homogeneous series	24
Table 7 – Testing schedule for all intermediate ampere ratings of a homogeneous series	24
Table A.1 – Guidance on ratings to be specified by the manufacturer or to be agreed upon with the testing house	28

iTech STANDARD PREVIEW
 (standards.iteh.ai)
 IEC 60127-7:2015
<https://standards.iteh.ai/catalog/standards/sist/c58fadf6-ce78-495d-97de-bb4ee4eda9ad/iec-60127-7-2015>

INTERNATIONAL ELECTROTECHNICAL COMMISSION

MINIATURE FUSES –

Part 7: Miniature fuse-links for special applications

FOREWORD

- 1) The International Electrotechnical Commission (IEC) is a worldwide organization for standardization comprising all national electrotechnical committees (IEC National Committees). The object of IEC is to promote international co-operation on all questions concerning standardization in the electrical and electronic fields. To this end and in addition to other activities, IEC publishes International Standards, Technical Specifications, Technical Reports, Publicly Available Specifications (PAS) and Guides (hereafter referred to as "IEC Publication(s)"). Their preparation is entrusted to technical committees; any IEC National Committee interested in the subject dealt with may participate in this preparatory work. International, governmental and non-governmental organizations liaising with the IEC also participate in this preparation. IEC collaborates closely with the International Organization for Standardization (ISO) in accordance with conditions determined by agreement between the two organizations.
- 2) The formal decisions or agreements of IEC on technical matters express, as nearly as possible, an international consensus of opinion on the relevant subjects since each technical committee has representation from all interested IEC National Committees.
- 3) IEC Publications have the form of recommendations for international use and are accepted by IEC National Committees in that sense. While all reasonable efforts are made to ensure that the technical content of IEC Publications is accurate, IEC cannot be held responsible for the way in which they are used or for any misinterpretation by any end user.
- 4) In order to promote international uniformity, IEC National Committees undertake to apply IEC Publications transparently to the maximum extent possible in their national and regional publications. Any divergence between any IEC Publication and the corresponding national or regional publication shall be clearly indicated in the latter.
<http://standards.iteh.ai/catalog/standards/sist/c586-d6-ec78-495d-97dc-6e3cc3cc6015/iec-60127-7-2015>
- 5) IEC itself does not provide any attestation of conformity. Independent certification bodies provide conformity assessment services and, in some areas, access to IEC marks of conformity. IEC is not responsible for any services carried out by independent certification bodies.
- 6) All users should ensure that they have the latest edition of this publication.
- 7) No liability shall attach to IEC or its directors, employees, servants or agents including individual experts and members of its technical committees and IEC National Committees for any personal injury, property damage or other damage of any nature whatsoever, whether direct or indirect, or for costs (including legal fees) and expenses arising out of the publication, use of, or reliance upon, this IEC Publication or any other IEC Publications.
- 8) Attention is drawn to the Normative references cited in this publication. Use of the referenced publications is indispensable for the correct application of this publication.
- 9) Attention is drawn to the possibility that some of the elements of this IEC Publication may be the subject of patent rights. IEC shall not be held responsible for identifying any or all such patent rights.

International Standard IEC 60127-7 has been prepared by subcommittee 32C: Miniature fuses, of IEC technical committee 32: Fuses.

This bilingual version (2018-03) corresponds to the monolingual English version, published in 2015-09.

This second edition cancels and replaces the first edition published in 2013.

This edition includes the following significant technical changes with respect to the previous edition:

- a) defining a test board for surface mount fuse-links, Figure 2;
- b) defining test schedules for homogenous series.

The text of this standard is based on the following documents:

CDV	Report on voting
32C/507/CDV	32C/513/RVC

Full information on the voting for the approval of this standard can be found in the report on voting indicated in the above table.

The French version of this standard has not been voted upon.

This publication has been drafted in accordance with the ISO/IEC Directives, Part 2.

A list of all parts in the IEC 60127 series, published under the general title *Miniature fuses*, can be found on the IEC website.

This International Standard is to be used in conjunction with IEC 60127-1:2006, *Miniature fuses – Part 1: Definitions for miniature fuses and general requirements for miniature fuse-links* and its Amendment 1 (2011).

The clauses of this standard supplement, modify or replace the corresponding clauses in IEC 60127-1.

Where there is no corresponding clause or subclause in this standard, the clause or subclause of IEC 60127-1 applies without modification as far as is reasonable. When this standard states “addition” or “replacement”, the relevant text in IEC 60127-1 is to be adapted accordingly.

Subclauses which are additional to those in Part 1 are numbered starting from 101. Additional annexes are numbered AA, BB, etc.

The committee has decided that the contents of this publication will remain unchanged until the stability date indicated on the IEC website under "<http://webstore.iec.ch>" in the data related to the specific publication. At this date, the publication will be

- reconfirmed,
- withdrawn,
- replaced by a revised edition, or
- amended.

INTRODUCTION

According to the wish expressed by the users of miniature fuses, all standards, recommendations and other documents relating to miniature fuses should have the same publication number in order to facilitate reference to fuses in other specifications, for example, equipment specifications.

Furthermore, a single publication number and subdivision into parts would facilitate the establishment of new standards, because clauses containing general requirements need not be repeated.

The IEC 60127 series, under the general heading *Miniature fuses*, is thus subdivided as follows:

IEC 60127-1, *Miniature fuses – Part 1: Definitions for miniature fuses and general requirements for miniature fuse-links*

IEC 60127-2, *Miniature fuses – Part 2: Cartridge fuse-links*

IEC 60127-3, *Miniature fuses – Part 3: Sub-miniature fuse-links*

IEC 60127-4, *Miniature fuses – Part 4: Universal modular fuse-links (UMF) – Through-hole and surface mount types*

IEC 60127-5, *Miniature fuses – Part 5: Guidelines for quality assessment of miniature fuse-links*

IEC 60127-6, *Miniature fuses – Part 6: Fuse-holders for miniature fuse-links*

IEC 60127-7, *Miniature fuses – Part 7: Miniature fuse-links for special applications*

IEC 60127-8, (Free for further documents)

IEC 60127-9, (Free for further documents)

IEC 60127-10, *Miniature fuses – Part 10: User guide for miniature fuses*

MINIATURE FUSES –

Part 7: Miniature fuse-links for special applications

1 Scope

This part of IEC 60127 covers requirements for miniature fuse-links for special applications.

This part of IEC 60127 is applicable to fuse-links with a rated voltage not exceeding 1 000 V, a rated current not exceeding 20 A and a rated breaking capacity not exceeding 50 kA.

It does not apply to fuses completely covered by the subsequent parts of IEC 60269-1.

It does not apply to miniature fuse-links for appliances intended to be used under special conditions, such as in corrosive or explosive atmospheres.

This part of IEC 60127 applies in addition to the requirements of IEC 60127-1.

Miniature fuse-links for special applications are not intended to be replaced by the end-user of an electrical / electronic appliance.

The object of this part of IEC 60127 is to establish uniform test methods for miniature fuse-links for special applications, so as to allow verification of the values (for example melting time and breaking capacity values) specified by the manufacturer.

<https://standards.iteh.ai/catalog/standards/sist/c58fadf6-cc78-495d-97de-bb4ee4eda9ad/iec-60127-7-2015>

2 Normative references

The following documents, in whole or in part, are normatively referenced in this document and are indispensable for its application. For dated references, only the edition cited applies. For undated references, the latest edition of the referenced document (including any amendments) applies.

IEC 60068-2-21:2006, *Environmental testing – Part 2-21: Tests – Test U: Robustness of terminations and integral mounting devices*

IEC 60127-1:2006, *Miniature fuses – Part 1: Definitions for miniature fuses and general requirements for miniature fuse-links*

IEC 60127-1:2006/AMD1:2011

IEC 60127-1:2006/AMD2:2015

IEC 60127-4:2005, *Miniature fuses – Part 4: Universal modular fuse-links (UMF) – Through-hole and surface mount types*

IEC 60127-4:2005/AMD1:2008

IEC 60127-4:2005/AMD2:2012

IEC 60127-6:2014, *Miniature fuses – Part 6: Fuse-holders for miniature fuse-links*

IEC 60664-1:2007, *Insulation coordination for equipment within low-voltage systems – Part 1: Principles, requirements and tests*

IEC 60695-2-12:2010, *Fire hazard testing – Part 2-12: Glowing/hot-wire based test methods – Glow-wire flammability index (GWFI) test method for materials*
IEC 60695-2-12:2010/AMD1:2014

IEC 60695-2-13:2010, *Fire hazard testing – Part 2-13: Glowing/hot-wire based test methods – Glow-wire ignition temperature (GWIT) test method for materials*
IEC 60695-2-13:2010/AMD1:2014

IEC 60695-4:2012, *Fire hazard testing – Part 4: Terminology concerning fire tests for electrotechnical products*

IEC 61249-2-7:2002, *Materials for printed boards and other interconnecting structures – Part 2-7: Reinforced base materials clad and unclad – Epoxide woven E-glass laminated sheet of defined flammability (vertical burning test), copper-clad*

ISO 3:1973, *Preferred numbers – Series of preferred numbers*

3 Terms and definitions

For the purposes of this document, the terms and definitions given in Clause 3 of IEC 60127-1:2006, except 3.5, as well as the following apply.

3.1

miniature fuse-link for special applications

enclosed fuse-link which is not covered in IEC 60127-2, IEC 60127-3 or IEC 60127-4 and of rated breaking capacity not exceeding 50 kA, with a width and height not exceeding 12 mm and a length not exceeding 50 mm

IEC 60127-7:2015

Note 1 to entry: Special precautions may be necessary to ensure that the fuse-links will be replaced by a fuse-link with the same technical parameters.

Note 2 to entry: For fuse-links having a metallic cap at each end, any member of terminals or terminations other than the metallic cap such as wire terminations, pins and bolt-in contacts may not be included in the total length of 50 mm and the width and height of 12 mm.

3.2

t_1 to t_8

limit values for time/current characteristic

3.3

I_{70}

test current for testing at elevated temperature of 70 °C

Note 1 to entry: Preferred values are 0,8 I_N or 1,0 I_N or 1,1 I_N .

3.4

$I_{\text{test}}(\text{A})$

test current for endurance testing according to method A

Note 1 to entry: Preferred values are 1,0 I_N or 1,05 I_N or 1,2 I_N .

3.5

$I_{\text{test}}(\text{B})$

test current for endurance testing according to method B

Note 1 to entry: Preferred values are 0,8 I_N or 1,0 I_N .

3.6 **$I_{OVL(A)}$**

test current for measuring the maximum sustained dissipation according to method A

Note 1 to entry: Preferred values are $1,25 I_N$ or $1,35 I_N$ or $1,5 I_N$.

3.7 **$I_{OVL(B)}$**

test current for measuring the maximum sustained dissipation according to method B

Note 1 to entry: Preferred values are $1,0 I_N$ or $1,25 I_N$.

4 General requirements

Clause 4 of IEC 60127-1:2006 applies.

5 Standard ratings

Clause 5 of IEC 60127-1:2006 does not apply.

Replacement:

The following ratings shall be agreed upon between the testing house and the manufacturer:

- rated voltage;
- rated current (see standard sheet 1 for preferred ratings);
- rated breaking capacity (a.c. and/or d.c.);
- time/current characteristic (at least at $2,0 I_N$ or $2,1 I_N$ and $10 I_N$).

The following may be agreed upon on an optional basis:

- test at elevated temperature;
- time/current characteristic (additionally at $2,75 I_N$ and $4 I_N$).

Any additional specified values are given in standard sheet 1.

6 Marking

Clause 6 of IEC 60127-1:2006 applies except as follows.

6.1

Replacement:

d) Not applicable.

NOTE A symbol denoting the time/current characteristic cannot be stated, because this part of IEC 60127 does not specify any values for this parameter.

Addition:

- e) Type designation.
- f) Rated breaking capacity in amperes (A) or in kilo amperes (kA).

6.2

Deletion of NOTE 2.

6.3

Addition after first paragraph:

Furthermore the rated breaking capacity in amperes (A) or in kilo amperes (kA) shall be marked on the package label.

6.4

Addition of heading title and replacement of text:

6.4 Colour coding for miniature fuse-links for special applications

Marking of fuse-links by means of colour bands according to IEC 60127-1:2006, Annex A, is not permitted. It is, however, possible to use colour markings that clearly differ from this colour band system. In this case, the manufacturer shall provide the relevant information, for example colour key.

Additional subclause:

6.101 Where marking is impracticable due to space limitations, the relevant information should appear on the smallest package and in the manufacturer's technical literature.

7 General notes on tests

Clause 7 of IEC 60127-1:2006 applies except as follows.

7.2 Type tests

7.2.1

Replacement:

For testing the individual current ratings of fuses with a.c. or d.c. breaking capacity, the number of fuse-links required is 51, of which 12 are kept as spares. For fuse-links with wire terminations six extra samples (E1 to E6) have to be taken by random and not sorted according to voltage drop. If necessary, these samples can be used as additional spares after performing the tests according to 8.3.

The testing schedule is shown in Table 2.

For testing the individual current ratings of fuses with a.c. and d.c. breaking capacity, the number of fuse-links required is 63, of which 9 are kept as spares. For fuse-links with wire terminations six extra samples (E1 to E6) have to be taken by random and not sorted according to voltage drop. If necessary, these samples can be used as additional spares after performing the tests according to 8.3. The testing schedule is shown in Table 3.

For testing the maximum ampere rating of a homogenous series with a.c. or d.c. breaking capacity the number of fuse-links required is 51, of which 22 are kept as spares. For fuse-links with wire terminations six extra samples (E1 to E6) have to be taken by random and not sorted according to voltage drop. If necessary, these samples can be used as additional spares after performing the tests according to 8.3.

The testing schedule is shown in Table 4.

ITC STANDARD PREVIEW
(standards.iteh.ai)

[IEC 60127-7:2015](https://standards.iteh.ai/catalog/standards/sist/c58fadf6-cc78-495d-97de-bb4ee4eda9ad/iec-60127-7-2015)

<https://standards.iteh.ai/catalog/standards/sist/c58fadf6-cc78-495d-97de-bb4ee4eda9ad/iec-60127-7-2015>

For testing the maximum ampere rating of a homogenous series with a.c. and d.c. breaking capacity the number of fuse-links required is 66, of which 32 are kept as spares. For fuse-links with wire terminations six extra samples (E1 to E6) have to be taken by random and not sorted according to voltage drop. If necessary, these samples can be used as additional spares after performing the tests according to 8.3.

The testing schedule is shown in Table 5.

For testing the minimum ampere rating of a homogenous series with a.c. and / or d.c. breaking capacity the number of fuse-links required is 38, of which 16 are kept as spares.

The testing schedule is shown in Table 6.

For testing all of the intermediate ampere rating of a homogenous series with a.c. and / or d.c. breaking capacity the number of fuse-links required is 38, of which 16 are kept as spares.

The testing schedule is shown in Table 7.

7.3 Fuse-bases for tests

Addition after first paragraph:

For fuse-links designed for use in a special type of fuse-holder, testing shall be performed in that fuse-holder.

For tests that require a printed circuit board for mounting and connection of the fuse-links, a test board according to Figure 1 or Figure 2 shall be used.

The test board according to Figure 1 shall be used for fuse links with wire terminations intended for insertion in suitably designed holes or sockets.

The test board according to Figure 2 shall be used for surface mount fuse-links.

When two or more fuse-links are tested in series, the fuse-bases shall be located so that there will be a spacing of not less than 50 mm between any two fuse-links under testing. The conductor connecting the fuse-bases together, and connecting the fuse-bases to the ammeter and the source of supply shall be insulated copper wire. The length of each conductor shall be 500 mm and the cross-sectional area of the wire shall be approximately 1 mm² for fuse-links with rated currents up to and including 6,3 A, and 6 mm² for rated currents exceeding 6,3 A.

Dimensions in millimetres

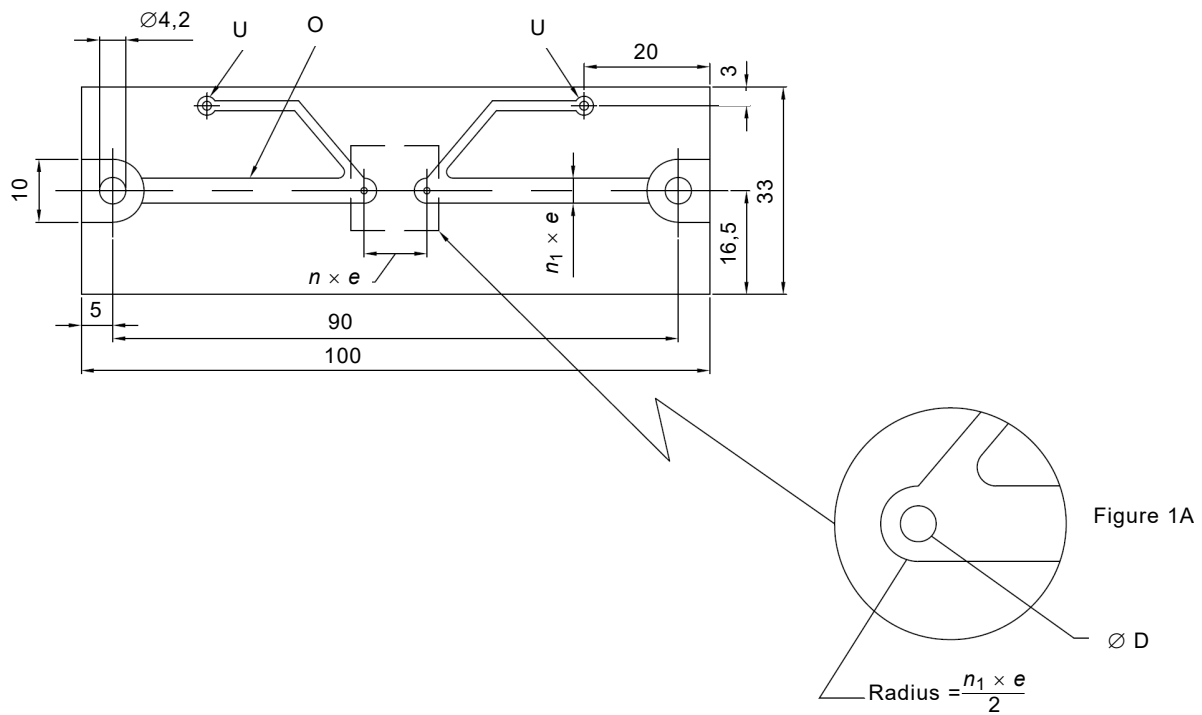

iTeh STANDARD PREVIEW (standards.iteh.ai)

IEC

Key

O copper layer; thickness 0,035 mm or 0,070 mm

U connection for voltage drop measurement [IEC 60127-7:2015](https://standards.iteh.ai/catalog/standards/sist/c58fadf6-ce78-495d-97de-bb4ee4eda9ad/iec-60127-7-2015)

D diameter of 1 mm for rated currents up to and including 6,3 A;
diameter of 1,5 mm for rated currents exceeding 6,3 A.

e 2,5 mm

n_1 1, 2, 3, 4

n 1, 2, 3 ... (to be adapted depending on the length of the fuse-link)

Figure 1 – Standard test board for fuse-links with wire terminations

This test board shall be mounted on the fuse-base according to Figure 3a.

Dimensions in millimetres

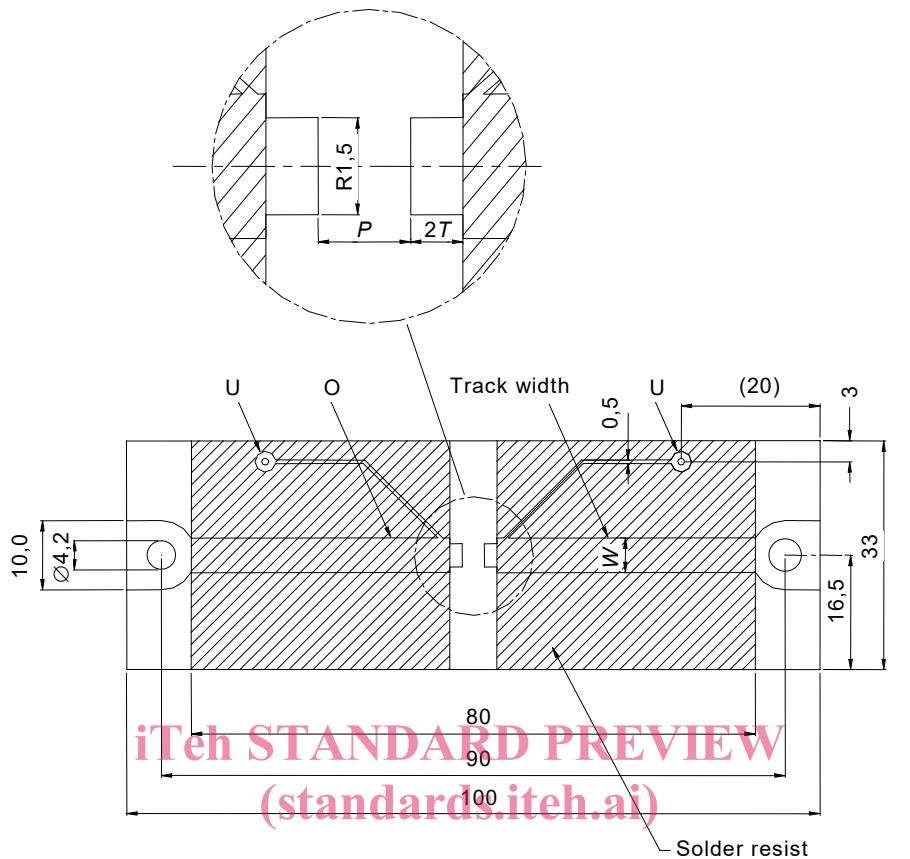

IEC 60127-7:2015

IEC

<https://standards.iteh.ai/catalog/standards/sist/c58fadf6-cc78-495d-97de-bb4ee4eda9ad/iec-60127-7-2015>

Key

O copper layer, thickness 0,035 mm or 0,070 mm

U connection for voltage drop measurement

W tracking width equals $n_1 \times e$ referring to Figure 1. For small devices, it may be necessary to use reduced track widths, representing normal use of these devices. This should be recorded in the test report and in the manufacturer's literature.

P terminal spacing

R refer to standard sheet 1, page 1

T refer to standard sheet 1, page 1

NOTE 1 Solder resist to be applied in hatched areas.

Figure 2 – Test board for surface mount fuse-links

This test board shall be mounted on the fuse-base according to Figure 3b.

The land areas should be suitably prepared for soldering.

A mechanical device may be used as long as it is demonstrated that the results are the same (not applicable to 9.7).

Dimensions in millimetres

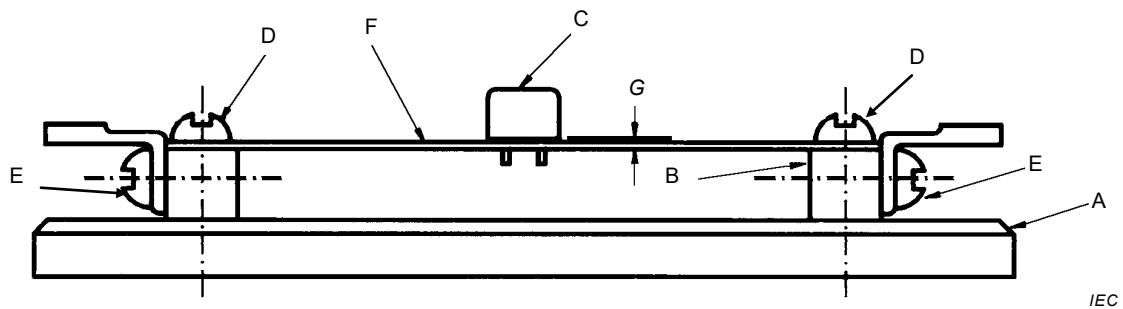

Figure 3a – Fuse-links with wire terminations (printed circuit track underneath)

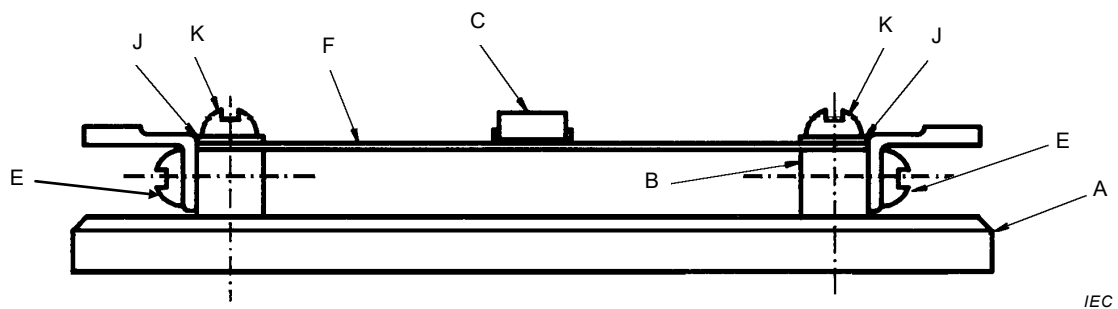
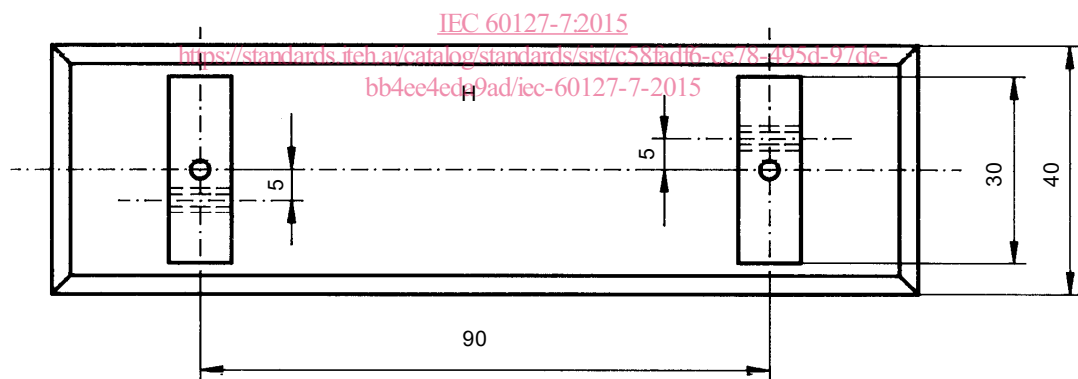

Figure 3b – Surface mount fuse-link (printed circuit track on top)
 iTeh STANDARD PREVIEW
 (standards.iteh.ai)

Dimensions in millimetres



IEC

- | | | | |
|---|---|---|--|
| A | base of low heat conducting material, thickness 10 mm | F | printed circuit board (see Figure 1 and Figure 2) |
| B | brass electrodes 10 mm × 10 mm | G | space between fuse body and board equals $(0,5 \pm 0,25)$ mm |
| C | Fuse-link soldered in place | H | top view of base with brass electrodes |
| D | fixing screws | J | silver-plated brass washer (two places) |
| E | contact screws holding solder terminal | K | silver-plated brass screw to make contact with the conducting surface on top of the printed circuit board (two places) |

Figure 3 – Test fuse base

The test board shall be made of epoxide woven glass fabric copper-clad laminated sheet, as defined in IEC 61249-2-7.

The nominal sheet thickness shall be 1,6 mm.