

TECHNICAL REPORT

AMENDMENT 1

High-voltage direct current (HVDC) systems – Application of active filters (standards.iteh.ai)

[IEC TR 62544:2011/AMD1:2016](#)

<https://standards.iteh.ai/catalog/standards/sist/8a8ba6b0-5656-4460-808e-a9b1abed005a/iec-tr-62544-2011-amd1-2016>



THIS PUBLICATION IS COPYRIGHT PROTECTED
Copyright © 2016 IEC, Geneva, Switzerland

All rights reserved. Unless otherwise specified, no part of this publication may be reproduced or utilized in any form or by any means, electronic or mechanical, including photocopying and microfilm, without permission in writing from either IEC or IEC's member National Committee in the country of the requester. If you have any questions about IEC copyright or have an enquiry about obtaining additional rights to this publication, please contact the address below or your local IEC member National Committee for further information.

IEC Central Office
3, rue de Varembe
CH-1211 Geneva 20
Switzerland

Tel.: +41 22 919 02 11
Fax: +41 22 919 03 00
info@iec.ch
www.iec.ch

About the IEC

The International Electrotechnical Commission (IEC) is the leading global organization that prepares and publishes International Standards for all electrical, electronic and related technologies.

About IEC publications

The technical content of IEC publications is kept under constant review by the IEC. Please make sure that you have the latest edition, a corrigenda or an amendment might have been published.

IEC Catalogue - webstore.iec.ch/catalogue

The stand-alone application for consulting the entire bibliographical information on IEC International Standards, Technical Specifications, Technical Reports and other documents. Available for PC, Mac OS, Android Tablets and iPad.

Electropedia - www.electropedia.org

The world's leading online dictionary of electronic and electrical terms containing 20 000 terms and definitions in English and French, with equivalent terms in 15 additional languages. Also known as the International Electrotechnical Vocabulary (IEV) online.

IEC publications search - www.iec.ch/searchpub

The advanced search enables to find IEC publications by a variety of criteria (reference number, text, technical committee,...). It also gives information on projects, replaced and withdrawn publications.

IEC Glossary - std.iec.ch/glossary

65 000 electrotechnical terminology entries in English and French extracted from the Terms and Definitions clause of IEC publications issued since 2002. Some entries have been collected from earlier publications of IEC TC 37, 77, 86 and CISPR.

IEC Just Published - webstore.iec.ch/justpublished

Stay up to date on all new IEC publications. Just Published details all new publications released. Available online and also once a month by email.

IEC Customer Service Centre - webstore.iec.ch/csc

If you wish to give us your feedback on this publication or need further assistance, please contact the Customer Service Centre: csc@iec.ch

<https://standards.iec.ch/catalog/standards>
a9b1abed005a/iec-tr-62544-2011-part-4.pdf-2016

TECHNICAL REPORT

AMENDMENT 1

High-voltage direct current (HVDC) systems – Application of active filters
(standards.iteh.ai)

IEC TR 62544:2011/AMD1:2016
<https://standards.iteh.ai/catalog/standards/sist/8a8ba6b0-5656-4460-808e-a9b1abed005a/iec-tr-62544-2011-amd1-2016>

INTERNATIONAL
ELECTROTECHNICAL
COMMISSION

ICS 29.240.99

ISBN 978-2-8322-3297-2

Warning! Make sure that you obtained this publication from an authorized distributor.

FOREWORD

This amendment has been prepared by subcommittee 22F: Power electronics for electrical transmission and distribution systems, of IEC technical committee 22: Power electronic systems and equipment.

The text of this amendment is based on the following documents:

DTR	Report on voting
22F/377/DTR	22F/381A/RVC

Full information on the voting for the approval of this amendment can be found in the report on voting indicated in the above table.

The committee has decided that the contents of this amendment and the base publication will remain unchanged until the stability date indicated on the IEC website under "<http://webstore.iec.ch>" in the data related to the specific publication. At this date, the publication will be

- reconfirmed,
- withdrawn,
- replaced by a revised edition, or
- amended.

 (standards.iteh.ai)

A bilingual version of this publication may be issued at a later date.

[IEC TR 62544:2011/AMD1:2016](#)

<https://standards.iteh.ai/catalog/standards/sist/8a8ba6b0-5656-4460-808e-a9b1abed005a/iec-tr-62544-2011-amd1-2016>

3 Terms and definitions

Replace the Note with the following new Note:

NOTE Only terms which are specific to active filters for HVDC are defined in this clause. Those terms that are either identical to or obvious extensions of IEC 60633, IEC 62001 and IEC 62747 terminology have not been defined.

3.3 Power semiconductor terms

Delete the Note.

3.3.1

insulated gate bipolar transistor IGBT

Replace the definition with the following new definition:

turn-off semiconductor device with a gate terminal (G) and two load terminals emitter (E) and collector (C)

Add, after definition 3.3.3, the following new term and definition:

3.3.4

turn-off semiconductor device

controllable semiconductor device which may be turned on and off by a control signal

EXAMPLE Insulated gate bipolar transistor (IGBT).

NOTE There are several types of turn-off semiconductor devices which can be used in active filters for HVDC. Currently, the IGBT is the major device used in such converters. The term IGBT is used throughout this Technical Report to refer to the turn-off semiconductor device. However, this Technical Report is equally applicable to other types of devices with turn-off capability in most of the parts.

3.4.2

two-level converter

Replace the definition with the following new definition:

converter in which the voltage between the a.c. terminals of the voltage sourced converter (VSC) unit and the VSC unit midpoint is switched between two discrete d.c. levels

3.4.3

three-level converter

Replace the definition with the following new definition:

converter in which the voltage between the a.c. terminals of the voltage sourced converter (VSC) unit and the VSC unit midpoint is switched between three discrete d.c. levels

Figure 4 – Simple current source converter

Replace Figure 4 with the following new figure:

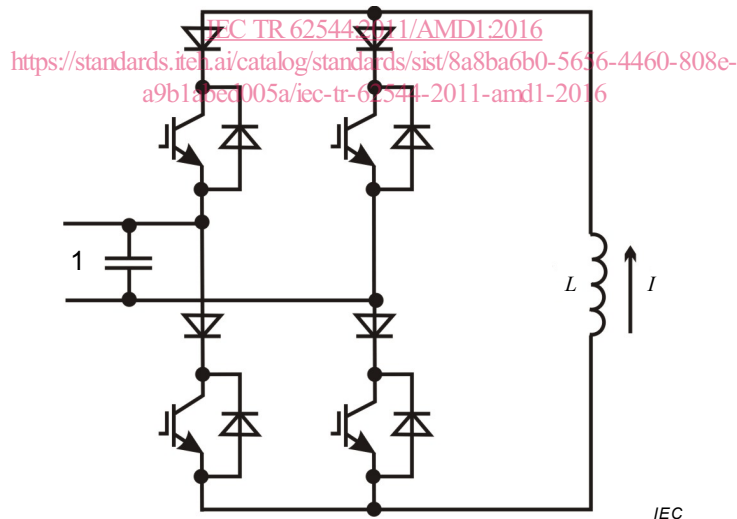

Key

1 AC current

Figure 4 – Simple current source converter

6.1 General

Replace the last sentence of the last paragraph with the following new sentence:

The power requirements for HV AC side can be considerably higher than for the HV DC side.

Figure 17 – Three phase current source converter

Replace Figure 17 with the following new figure:

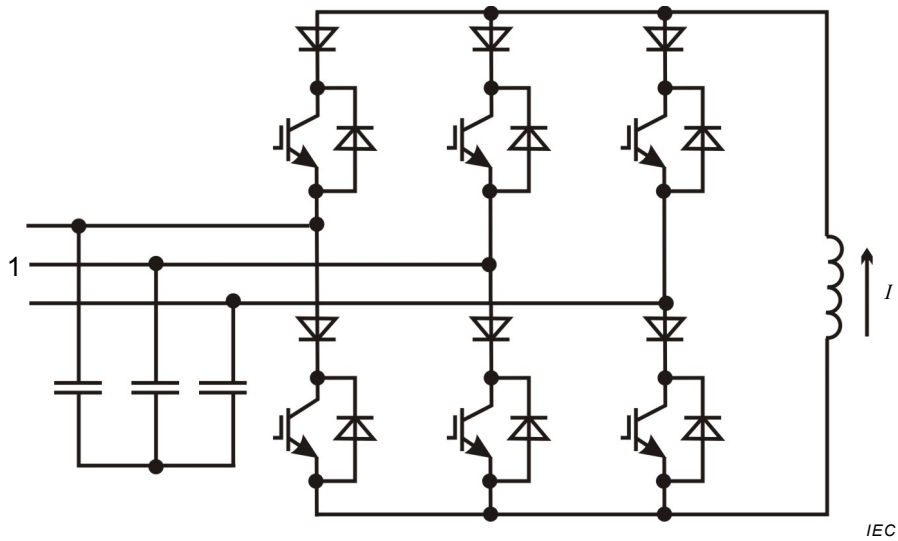

Key

1 AC grid

iTeh STANDARD PREVIEW
Figure 17 – Three phase current-source converter
(standards.iteh.ai)

Bibliography

[IEC TR 62544:2011/AMD1:2016](#)

Add to the bibliography the following new reference:
<https://standards.iteh.ai/catalog/standards/sist/8a8ba6b0-5656-4460-808e-a961abed005a/iec-tr-62544-2011-amd1-2016>

- [20] IEC 62747, Terminology for voltage-sourced converters (VSC) for high-voltage direct current (HVDC) systems

iTeh STANDARD PREVIEW
(standards.iteh.ai)

[IEC TR 62544:2011/AMD1:2016](https://standards.iteh.ai/catalog/standards/sist/8a8ba6b0-5656-4460-808e-a9b1abed005a/iec-tr-62544-2011-amd1-2016)

<https://standards.iteh.ai/catalog/standards/sist/8a8ba6b0-5656-4460-808e-a9b1abed005a/iec-tr-62544-2011-amd1-2016>

INTERNATIONAL
ELECTROTECHNICAL
COMMISSION

ITU STANDARD PREVIEW
(standards.iteh.ai)

3, rue de Varembé
PO Box 131
CH-1211 Geneva 20
Switzerland

[IEC TR 62544:2011/AMD1:2016](https://standards.iteh.ai/catalog/standards/sist/8a8ba6b0-5656-4460-808e-a9b1abed005a/iec-tr-62544-2011-amd1-2016)
<https://standards.iteh.ai/catalog/standards/sist/8a8ba6b0-5656-4460-808e-a9b1abed005a/iec-tr-62544-2011-amd1-2016>

Tel: + 41 22 919 02 11
Fax: + 41 22 919 03 00
info@iec.ch
www.iec.ch