

SLOVENSKI STANDARD
SIST EN 61000-4-28:2000/A2:2009
01-september-2009

Elektromagnetna združljivost (EMC) - 4-28. del: Preskusne in merilne tehnike - Preskus odpornosti proti spremembam napajalne frekvence (IEC 61000-4-28:1999/A2:2009)

Electromagnetic compatibility (EMC) -- Part 4-28: Testing and measurement techniques - Variation of power frequency, immunity test

Elektromagnetische Verträglichkeit (EMV) -- Teil 4-28: Prüf- und Messverfahren - Prüfung der Störfestigkeit gegen Schwankungen der energietechnischen Frequenz (Netzfrequenz)

Compatibilité électromagnétique (CEM) -- Partie 4-28: Techniques d'essai et de mesure - Essai d'immunité à la variation de la fréquence d'alimentation

Ta slovenski standard je istoveten z: EN 61000-4-28:2000/A2:2009

ICS:

33.100.20 Imunost Immunity

SIST EN 61000-4-28:2000/A2:2009 en

iTeh STANDARD PREVIEW
(standards.iteh.ai)

[SIST EN 61000-4-28:2000/A2:2009](https://standards.iteh.ai/catalog/standards/sist/35c8f14f-36cf-4591-86ba-ca9fd1d9dbc/sist-en-61000-4-28-2000-a2-2009)

<https://standards.iteh.ai/catalog/standards/sist/35c8f14f-36cf-4591-86ba-ca9fd1d9dbc/sist-en-61000-4-28-2000-a2-2009>

EUROPEAN STANDARD
NORME EUROPÉENNE
EUROPÄISCHE NORM

EN 61000-4-28/A2

May 2009

ICS 33.100.20

English version

**Electromagnetic compatibility (EMC) -
Part 4-28: Testing and measurement techniques -
Variation of power frequency, immunity test for equipment
with input current not exceeding 16 A per phase
(IEC 61000-4-28:1999/A2:2009)**

Compatibilité électromagnétique (CEM) -
Partie 4-28: Techniques d'essai
et de mesure -
Essai d'immunité à la variation
de la fréquence d'alimentation
pour des matériels avec un courant appelé
n'excédant pas 16 A par phase
(CEI 61000-4-28:1999/A2:2009)

Elektromagnetische Verträglichkeit (EMV) -
Teil 4-28: Prüf- und Messverfahren -
Prüfung der Störfestigkeit von Geräten
mit einem Eingangsstrom, der 16 A je Leiter
nicht überschreitet, gegen Schwankungen
der energietechnischen Frequenz
(Netzfrequenz)
(IEC 61000-4-28:1999/A2:2009)

[SIST EN 61000-4-28:2000/A2:2009](https://standards.iteh.ai/catalog/standards/sist/35c8f14f-36cf-4591-86ba-ca9f6d1d9dbc/sist-en-61000-4-28-2000-a2-2009)

<https://standards.iteh.ai/catalog/standards/sist/35c8f14f-36cf-4591-86ba-ca9f6d1d9dbc/sist-en-61000-4-28-2000-a2-2009>

This amendment A2 modifies the European Standard EN 61000-4-28:2000; it was approved by CENELEC on 2009-03-01. CENELEC members are bound to comply with the CEN/CENELEC Internal Regulations which stipulate the conditions for giving this amendment the status of a national standard without any alteration.

Up-to-date lists and bibliographical references concerning such national standards may be obtained on application to the Central Secretariat or to any CENELEC member.

This amendment exists in three official versions (English, French, German). A version in any other language made by translation under the responsibility of a CENELEC member into its own language and notified to the Central Secretariat has the same status as the official versions.

CENELEC members are the national electrotechnical committees of Austria, Belgium, Bulgaria, Cyprus, the Czech Republic, Denmark, Estonia, Finland, France, Germany, Greece, Hungary, Iceland, Ireland, Italy, Latvia, Lithuania, Luxembourg, Malta, the Netherlands, Norway, Poland, Portugal, Romania, Slovakia, Slovenia, Spain, Sweden, Switzerland and the United Kingdom.

CENELEC

European Committee for Electrotechnical Standardization
Comité Européen de Normalisation Electrotechnique
Europäisches Komitee für Elektrotechnische Normung

Central Secretariat: avenue Marnix 17, B - 1000 Brussels

Foreword

The text of document 77A/673/FDIS, future amendment 2 to IEC 61000-4-28:1999, prepared by SC 77A, Low frequency phenomena, of IEC TC 77, Electromagnetic compatibility, was submitted to the IEC-CENELEC parallel vote and was approved by CENELEC as amendment A2 to EN 61000-4-28:2000 on 2009-03-01.

The following dates were fixed:

- latest date by which the amendment has to be implemented at national level by publication of an identical national standard or by endorsement (dop) 2009-12-01
- latest date by which the national standards conflicting with the amendment have to be withdrawn (dow) 2012-03-01

Endorsement notice

The text of amendment 2:2009 to the International Standard IEC 61000-4-28:1999 was approved by CENELEC as an amendment to the European Standard without any modification.

iTeh STANDARD PREVIEW
(standards.iteh.ai)

[SIST EN 61000-4-28:2000/A2:2009](https://standards.iteh.ai/catalog/standards/sist/35c8f14f-36cf-4591-86ba-ca9f6d1d9dbc/sist-en-61000-4-28-2000-a2-2009)

<https://standards.iteh.ai/catalog/standards/sist/35c8f14f-36cf-4591-86ba-ca9f6d1d9dbc/sist-en-61000-4-28-2000-a2-2009>



IEC 61000-4-28

Edition 1.0 2009-02

INTERNATIONAL STANDARD

NORME INTERNATIONALE

BASIC EMC PUBLICATION
PUBLICATION FONDAMENTALE EN CEM

AMENDMENT 2
AMENDEMENT 2

iTeh STANDARD PREVIEW
(standards.iteh.ai)

Electromagnetic compatibility (EMC) –
Part 4-28: Testing and measurement techniques – Variation of power frequency,
immunity test for equipment with input current not exceeding 16 A per phase

Compatibilité électromagnétique (CEM) –
Partie 4-28: Techniques d'essai et de mesure – Essai d'immunité à la variation
de la fréquence d'alimentation pour des matériels avec un courant appelé
n'excédant pas 16 A par phase

INTERNATIONAL
ELECTROTECHNICAL
COMMISSION

COMMISSION
ELECTROTECHNIQUE
INTERNATIONALE

PRICE CODE
CODE PRIX

C

ICS 33.100.20

ISBN 2-8318-1027-3

FOREWORD

This amendment has been prepared by subcommittee 77A: Low-frequency phenomena, of IEC technical committee 77: Electromagnetic compatibility.

The text of this amendment is based on the following documents:

FDIS	Report on voting
77A/673/FDIS	77A/676/RVD

Full information on the voting for the approval of this amendment can be found in the report on voting indicated in the above table.

The committee has decided that the contents of this amendment and the base publication will remain unchanged until the maintenance result date indicated on the IEC web site under "<http://webstore.iec.ch>" in the data related to the specific publication. At this date, the publication will be

- reconfirmed,
- withdrawn,
- replaced by a revised edition, or
- amended.

iTeh STANDARD PREVIEW
(standards.iteh.ai)

[SIST EN 61000-4-28:2000/A2:2009](https://standards.iteh.ai/catalog/standards/sist/35c8f14f-36cf-4591-86ba-ca9f6d1d9dbc/sist-en-61000-4-28-2000-a2-2009)

<https://standards.iteh.ai/catalog/standards/sist/35c8f14f-36cf-4591-86ba-ca9f6d1d9dbc/sist-en-61000-4-28-2000-a2-2009>

Title

Amend the title of this standard on the cover page, the title page and throughout the document as follows:

**Part 4-28: Testing and measurement techniques –
Variation of power frequency, immunity test for equipment
with input current not exceeding 16 A per phase**

6.2 Verification of the characteristics

Replace the text of the entire subclause by the following text and Figure 4:

It is recognized that there is a wide range of EUTs, and that consequently test generators with different output power capabilities may be utilized, as required by particular tests.

It shall be verified that the test generator meets the characteristics and performance specifications as listed in Table 2.

Performance of the test generator shall be verified with a resistive load drawing an r.m.s. current of no more than the output capability of the generator. For example, a 230V/16A generator shall be verified with a 14,3 Ω load.

In addition, the generator's output current capability shall be verified as being able to provide a crest factor of at least 3 when U_N is applied to a single phase load drawing an rms current

of no more than the output capability of the generator. Each output phase of the generator shall be verified in turn. An example of a 230 V/16 A verification load is given in Figure 4.

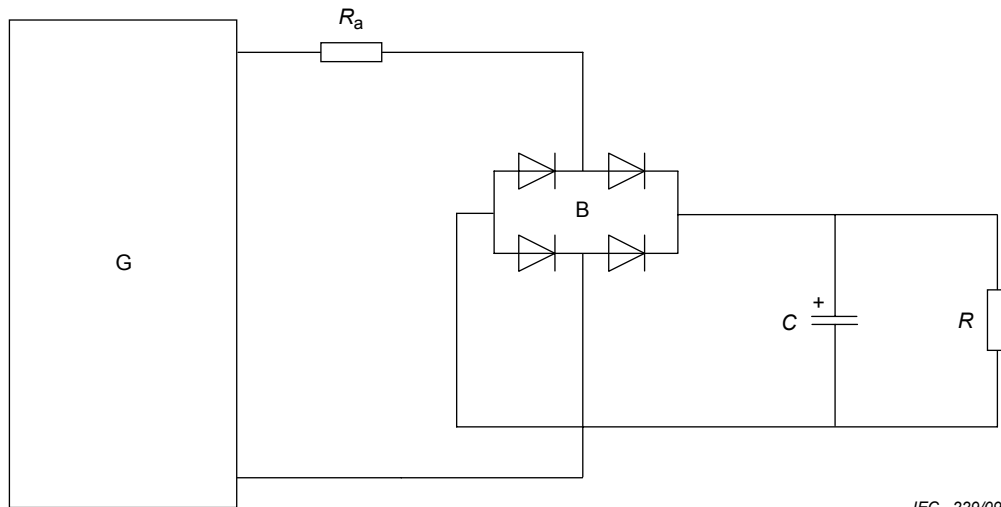

IEC 229/09

Components

G Test generator

B Bridge rectifier

C 11 000 $\mu\text{F} \pm 20\%$ electrolytic capacitor

R 61 $\Omega \pm 1\%$ resistor

R_a Additional resistor

iTeh STANDARD PREVIEW
(standards.iteh.ai)

[SIST EN 61000-4-28:2000/A2:2009](https://standards.iteh.ai/catalog/standards/sist/35c8f14f-36cf-4591-86ba-ca9f6d1d9dbc/sist-en-61000-4-28-2000-a2-2009)

<https://standards.iteh.ai/catalog/standards/sist/35c8f14f-36cf-4591-86ba-ca9f6d1d9dbc/sist-en-61000-4-28-2000-a2-2009>

NOTE R_a is selected so that the total series resistance (sum of the additional resistor R_a, the wiring resistance R_{wire}, the internal resistance of two conducting diodes R_{diodes} and the internal resistance of the capacitor R_c) is 92 m Ω ($\pm 10\%$).

Figure 4 – Example of test generator verification load