



**SLOVENSKI STANDARD
SIST EN 3856:2004**

01-maj-2004

Aerospace series - Pipe couplings, 60°, spherical, in titanium alloy TI-P64001 - Swivel nuts for thrust wire

Aerospace series - Pipe couplings, 60°, spherical, in titanium alloy TI-P64001 - Swivel nuts for thrust wire

Luft- und Raumfahrt - Rohrverschraubungen mit Kugelbuchsen, 60 ° , aus Titanlegierung TI-P64001 - Überwurfmutter für Schubdrähte

TECHNICAL STANDARD PREVIEW
(standards.iteh.ai)

[SIST EN 3856:2004](https://standards.iteh.ai/catalog/standards/sist/338e49a9-cf0b-4198-a304-4b43216a0822/sist-en-3856-2004)

Ta slovenski standard je istoveten z: **EN 3856:2002**

ICS:

49.080

Številni sistemi za tekočine in pline v letalstvu
Člani in delci

Aerospace fluid systems and components

SIST EN 3856:2004

en

iTeh STANDARD PREVIEW
(standards.iteh.ai)

[SIST EN 3856:2004](#)

<https://standards.iteh.ai/catalog/standards/sist/338e49a9-cf0b-4198-a304-4b45216a0822/sist-en-3856-2004>

EUROPEAN STANDARD
NORME EUROPÉENNE
EUROPÄISCHE NORM

EN 3856

November 2002

ICS 49.080

English version

Aerospace series - Pipe couplings, 60°, spherical, in titanium alloy TI-P64001 - Swivel nuts for thrust wire

Série aéronautique - Raccords sphériques, 60°, en alliage de titane TI-P64001 - Ecrous prisonniers à jonc

This European Standard was approved by CEN on 30 August 2002.

CEN members are bound to comply with the CEN/CENELEC Internal Regulations which stipulate the conditions for giving this European Standard the status of a national standard without any alteration. Up-to-date lists and bibliographical references concerning such national standards may be obtained on application to the Management Centre or to any CEN member.

This European Standard exists in three official versions (English, French, German). A version in any other language made by translation under the responsibility of a CEN member into its own language and notified to the Management Centre has the same status as the official versions.

CEN members are the national standards bodies of Austria, Belgium, Czech Republic, Denmark, Finland, France, Germany, Greece, Iceland, Ireland, Italy, Luxembourg, Malta, Netherlands, Norway, Portugal, Spain, Sweden, Switzerland and United Kingdom.

[SIST EN 3856:2004](https://standards.iteh.ai/catalog/standards/sist/338e49a9-cf0b-4198-a304-4b45216a0822/sist-en-3856-2004)

<https://standards.iteh.ai/catalog/standards/sist/338e49a9-cf0b-4198-a304-4b45216a0822/sist-en-3856-2004>



EUROPEAN COMMITTEE FOR STANDARDIZATION
COMITÉ EUROPÉEN DE NORMALISATION
EUROPÄISCHES KOMITEE FÜR NORMUNG

Management Centre: rue de Stassart, 36 B-1050 Brussels

Contents

Foreword.....	3
1 Scope	3
2 Normative references	3
3 Required characteristics	4
3.1 Configuration – Dimensions - Tolerances.....	4
3.2 Material.....	4
3.3 Surface coating	4
4 Designation.....	7
5 Marking	7
6 Quality assurance	7

iTeh STANDARD PREVIEW (standards.iteh.ai)

[SIST EN 3856:2004](https://standards.iteh.ai/catalog/standards/sist/338e49a9-cf0b-4198-a304-4b45216a0822/sist-en-3856-2004)

<https://standards.iteh.ai/catalog/standards/sist/338e49a9-cf0b-4198-a304-4b45216a0822/sist-en-3856-2004>

Foreword

This document (EN 3856:2002) has been prepared by the European Association of Aerospace Manufacturers – Standardization (AECMA-STAN).

After enquiries and votes carried out in accordance with the rules of this Association, this Standard has received the approval of the National Associations and the Official Services of the member countries of AECMA, prior to its presentation to CEN.

This European Standard shall be given the status of a national standard, either by publication of an identical text or by endorsement, at the latest by May 2003, and conflicting national standards shall be withdrawn at the latest by May 2003.

According to the CEN/CENELEC Internal Regulations, the national standards organizations of the following countries are bound to implement this European Standard: Austria, Belgium, Czech Republic, Denmark, Finland, France, Germany, Greece, Iceland, Ireland, Italy, Luxembourg, Malta, Netherlands, Norway, Portugal, Spain, Sweden, Switzerland and the United Kingdom.

1 Scope

This standard specifies the characteristics of swivel nuts for thrust wire for pipe couplings, 60°, spherical, in TI-P64001, for aerospace applications.

NOTE Assembly in accordance with TR 4052

iTeh STANDARD PREVIEW
(standards.iteh.ai)

2 Normative references

[SIST EN 3856:2004](#)

<https://standards.iteh.ai/catalog/standards/sist/338e49a9-cf0b-4198-a304-40a2e668>

This European Standard incorporates by dated or undated reference, provisions from other publications. These normative references are cited at the appropriate places in the text and the publications are listed hereafter. For dated references, subsequent amendments to or revisions of any of these publications apply to this European Standard only when incorporated in it by amendment or revision. For undated references the latest edition of the publication referred to applies (including amendments).

- | | |
|------------|------------------------------------------------------------------------------------------------------------------------------------------------------------------------------------|
| ISO 286-2 | <i>ISO system of limits and fits - Part 2: Tables of standard tolerance grades and limit deviations for holes and shafts.</i> |
| ISO 4156 | <i>Straight cylindrical involute splines - Metric module, side fit - Generalities, dimensions and inspection.</i> |
| ISO 5855-3 | <i>Aerospace - MJ threads - Part 3: Limit dimensions for fittings for fluid systems.</i> |
| EN 2000 | <i>Aerospace series - Quality assurance - EN aerospace products - Approval of the quality system of manufacturers.</i> |
| EN 2424 | <i>Aerospace series - Marking of aerospace products.</i> |
| EN 2491 | <i>Aerospace series - Molybdenum disulphide dry lubricants - Coating methods.</i> |
| EN 2530 | <i>Aerospace series - Titanium alloy TI-P63 - Annealed - $900 \text{ MPa} \leq R_m \leq 1160 \text{ MPa}$ - Bars $D_e \leq 150 \text{ mm}$¹⁾.</i> |
| TR 4052 | <i>Aerospace series - Pipe couplings, 60°, spherical, in titanium alloy - Assembly recommendations²⁾.</i> |

1) Published as AECMA Standard at the date of publication of this standard

2) Published as AECMA Technical Report at the date of publication of this standard

EN 3856:2002 (E)

3 Required characteristics

3.1 Configuration – Dimensions - Tolerances

See Figure 1 and Table 1. Dimensions and tolerances are in millimetres. They apply before lubrication.

3.2 Material

EN 2530

3.3 Surface coating

EN 2491

iTeh STANDARD PREVIEW
(standards.iteh.ai)

[SIST EN 3856:2004](#)

<https://standards.iteh.ai/catalog/standards/sist/338e49a9-cf0b-4198-a304-4b45216a0822/sist-en-3856-2004>

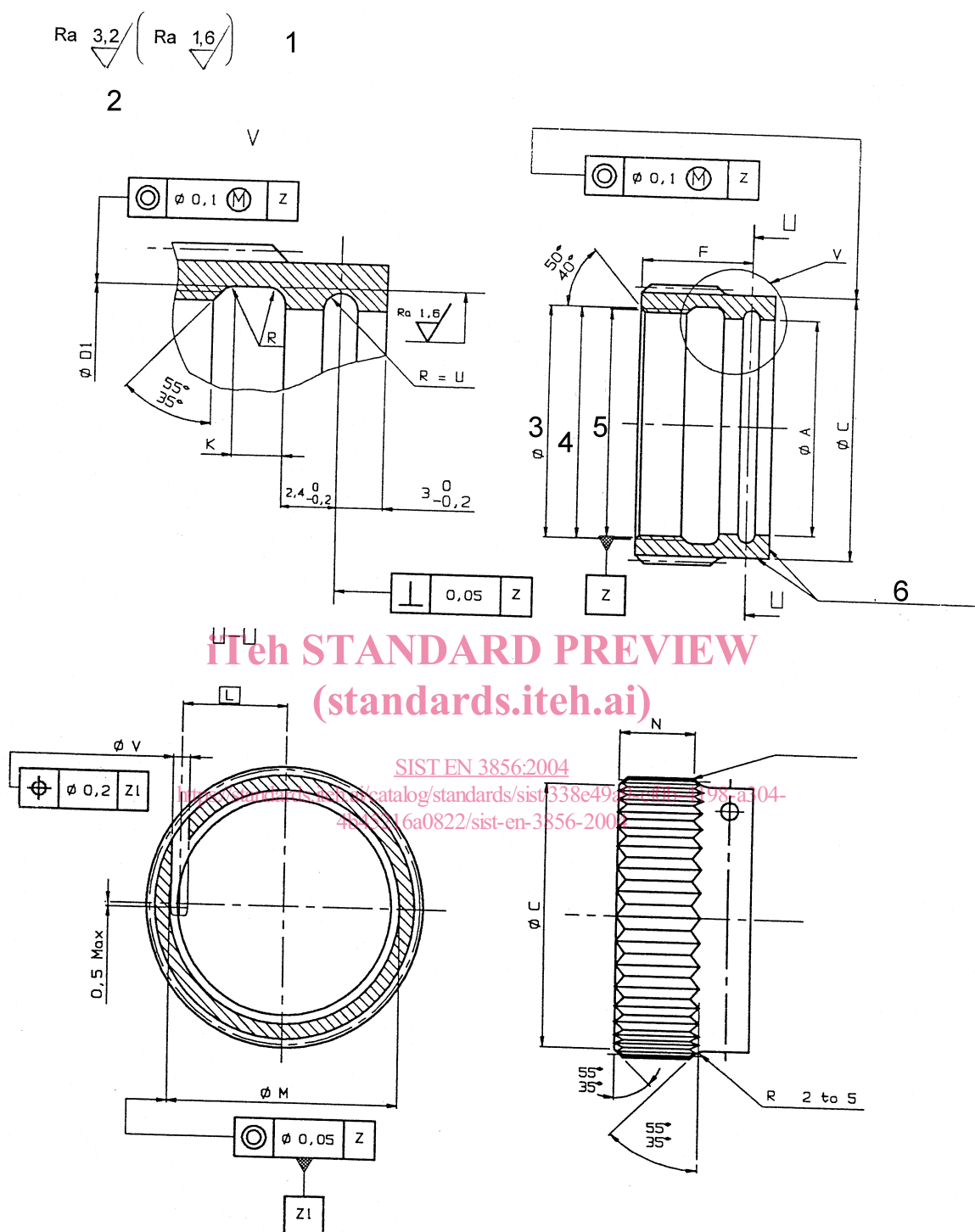

Key

- 1 Values apply before coating. Thread's surface will be as achieved by normal methods of manufacture.
- 2 Remove sharp edges 0,1 to 0,4
- 3 Chamf. D
- 4 Thread
- 5 Pitch diameter
- 6 Optional location marking

Figure 1

Table 1

Diameter code	Tube nominal diameter	Thread ^a	Splines ^b	A +0,1 0	C h13 ^c	D +0,5 0	D ₁ +0,2 0	F ± 0,1	K +0,2 0	L	M +0,1 0	N ± 0,2	R	U +0,1 0	V +0,2 0		
040	4	MJ10x1-4H5H	Ext18Zx0,75 mx45Rx6h	8,3	12,4	10,3	10,3	9,9	1,6	3,9	9,9	7	0,6 to 1	0,9	1,8		
060	6	MJ14x1,5-4H5H	Ext24Zx0,75 mx45Rx6h	11,6	16,9	14,4	14,4	12,4	2,4	5,55	13,2	9,5	1,1 to 1,5			1,1	2,2
080	8	MJ16x1,5-4H5H	Ext27Zx0,75 mx45Rx6h	13,6	19,2	16,4	16,4			6,55	15,2						
100	10	MJ18x1,5-4H5H	Ext30Zx0,75 mx45Rx6h	15,6	21,4	18,4	18,4			7,55	17,6						
120	12	MJ20x1,5-4H5H	Ext32Zx0,75 mx45Rx6h	17,6	22,9	20,4	20,4	13,9	3,75	8,55	19,6	10,5	1,1 to 1,5	1,1	2,2		
140	14	MJ22x1,5-4H5H	Ext35Zx0,75 mx45Rx6h	19,6	25,15	22,4	22,4			9,55	21,6						
160	16	MJ24x1,5-4H5H	Ext38Zx0,75 mx45Rx6h	21,6	27,4	24,4	24,4			10,55	23,6						
180	18	MJ27x1,5-4H5H	Ext32Zx1 mx45Rx6h	24,6	30,6	27,4	27,4	13,9	3,75	12,55	26,6	10,5	1,1 to 1,5	1,1	2,2		
200	20	MJ30x1,5-4H5H	Ext35Zx1 mx45Rx6h	27,6	33,6	30,4	30,4			13,55	29,6						
250	25	MJ36x1,5-4H5H	Ext41Zx1 mx45Rx6h	33,6	39,6	36,4	36,4			16,55	35,6						

^a In accordance with ISO 5855-3

^b In accordance with ISO 4156

^c Tolerance in accordance with ISO 286-2

SIST EN 3856:2004
 g:\standards\it\ce\3856\standards\siv\338e49a9-cf0b-4198-a304-452-a0822\sist-en-3856-2004

iTeh STANDARD PREVIEW
 (standards.iteh.ai)