



SLOVENSKI STANDARD SIST EN 3857:2004

01-maj-2004

Aerospace series - Pipe couplings, 60°, spherical, in titanium alloy TI-P64001 - Elbows 90°, welded

Aerospace series - Pipe couplings, 60°, spherical, in titanium alloy TI-P64001 - Elbows 90°, welded

Luft- und Raumfahrt - Rohrverschraubungen mit Kugelbuchsen, 60 ° , aus Titanlegierung TI-P64001 - Winkelverschraubungen 90 ° , zum Anschweißen

THIS STANDARD PREVIEW
(standards.iteh.ai)

[SIST EN 3857:2004](https://standards.iteh.ai/catalog/standards/sist/4f4f018-f536-4cc7-8da9-b523c6df348/sist-en-3857-2004)

Ta slovenski standard je istoveten z: **EN 3857:2002**

ICS:

49.080 Številni sistemi za tekočine in pline v letalstvu in vesoljskih sistemih in komponentah
Aerospace fluid systems and components

SIST EN 3857:2004 en

iTeh STANDARD PREVIEW
(standards.iteh.ai)

[SIST EN 3857:2004](#)

<https://standards.iteh.ai/catalog/standards/sist/4fc4f018-f536-4cc7-8da9-b525cd6df348/sist-en-3857-2004>

EUROPEAN STANDARD
NORME EUROPÉENNE
EUROPÄISCHE NORM

EN 3857

November 2002

ICS 49.080

English version

Aerospace series - Pipe couplings, 60°, spherical, in titanium alloy TI-P64001 - Elbows 90°, welded

Série aérospatiale - Raccords sphériques, 60°, en alliage de titane Ti-P64001 - Raccords coudés à 90°, à souder

This European Standard was approved by CEN on 30 August 2002.

CEN members are bound to comply with the CEN/CENELEC Internal Regulations which stipulate the conditions for giving this European Standard the status of a national standard without any alteration. Up-to-date lists and bibliographical references concerning such national standards may be obtained on application to the Management Centre or to any CEN member.

This European Standard exists in three official versions (English, French, German). A version in any other language made by translation under the responsibility of a CEN member into its own language and notified to the Management Centre has the same status as the official versions.

CEN members are the national standards bodies of Austria, Belgium, Czech Republic, Denmark, Finland, France, Germany, Greece, Iceland, Ireland, Italy, Luxembourg, Malta, Netherlands, Norway, Portugal, Spain, Sweden, Switzerland and United Kingdom.

SIST EN 3857:2004

<https://standards.iteh.ai/catalog/standards/sist/4fc4f018-f536-4cc7-8da9-b525cd6df348/sist-en-3857-2004>



EUROPEAN COMMITTEE FOR STANDARDIZATION
COMITÉ EUROPÉEN DE NORMALISATION
EUROPÄISCHES KOMITEE FÜR NORMUNG

Management Centre: rue de Stassart, 36 B-1050 Brussels

Contents

Foreword.....	3
1 Scope	3
2 Normative references	3
3 Required characteristics	4
3.1 Configuration – Dimensions – Tolerances.....	4
3.2 Material.....	4
4 Designation.....	8
5 Marking	8
6 Quality assurance	8

iTeh STANDARD PREVIEW (standards.iteh.ai)

[SIST EN 3857:2004](#)

<https://standards.iteh.ai/catalog/standards/sist/4fc4f018-f536-4cc7-8da9-b525cd6df348/sist-en-3857-2004>

Foreword

This document (EN 3857:2002) has been prepared by the European Association of Aerospace Manufacturers – Standardization (AECMA-STAN).

After enquiries and votes carried out in accordance with the rules of this Association, this Standard has received the approval of the National Associations and the Official Services of the member countries of AECMA, prior to its presentation to CEN.

This European Standard shall be given the status of a national standard, either by publication of an identical text or by endorsement, at the latest by May 2003, and conflicting national standards shall be withdrawn at the latest by May 2003.

According to the CEN/CENELEC Internal Regulations, the national standards organizations of the following countries are bound to implement this European Standard: Austria, Belgium, Czech Republic, Denmark, Finland, France, Germany, Greece, Iceland, Ireland, Italy, Luxembourg, Malta, Netherlands, Norway, Portugal, Spain, Sweden, Switzerland and the United Kingdom.

1 Scope

This standard specifies the characteristics of welded elbows 90° for pipe couplings, 60°, spherical, in TI-P64001, for aerospace applications.

iTeh STANDARD PREVIEW
(standards.iteh.ai)

NOTE Assembly in accordance with TR 4052 [SIST EN 3857:2004](#)

<https://standards.iteh.ai/catalog/standards/sist/4fc4f018-f536-4cc7-8da9-b525cd6df348/sist-en-3857-2004>

2 Normative references

This European Standard incorporates by dated or undated reference, provisions from other publications. These normative references are cited at the appropriate places in the text and the publications are listed hereafter. For dated references, subsequent amendments to or revisions of any of these publications apply to this European Standard only when incorporated in it by amendment or revision. For undated references the latest edition of the publication referred to applies (including amendments).

- | | |
|---------|--|
| EN 2000 | <i>Aerospace series - Quality assurance - EN aerospace products - Approval of the quality system of manufacturers.</i> |
| EN 2424 | <i>Aerospace series - Marking of aerospace products.</i> |
| EN 2530 | <i>Aerospace series - Titanium alloy TI-P63 - Annealed - $900 \text{ MPa} \leq R_m \leq 1160 \text{ MPa}$ - Bars $D_e \leq 150 \text{ mm}$¹⁾.</i> |
| EN 2656 | <i>Aerospace series – Pipe coupling – Coupling end, welded – Geometrical configuration.</i> |
| TR 4052 | <i>Aerospace series - Pipe couplings, 60°, spherical, in titanium alloy - Assembly recommendations²⁾.</i> |

1) Published as AECMA Standard at the date of publication of this standard

2) Published as AECMA Technical Report at the date of publication of this standard

EN 3857:2002 (E)

3 Required characteristics

3.1 Configuration – Dimensions – Tolerances

See Figures 1 and 2 and Table 1. Dimensions and tolerances are in millimetres.

3.2 Material

EN 2530

iTeh STANDARD PREVIEW
(standards.iteh.ai)

[SIST EN 3857:2004](https://standards.iteh.ai/catalog/standards/sist/4fc4f018-f536-4cc7-8da9-b525cd6df348/sist-en-3857-2004)

<https://standards.iteh.ai/catalog/standards/sist/4fc4f018-f536-4cc7-8da9-b525cd6df348/sist-en-3857-2004>

Fitting ends

Dimensional code

040060 to 100100

120060 to 140100

160060 to 250100

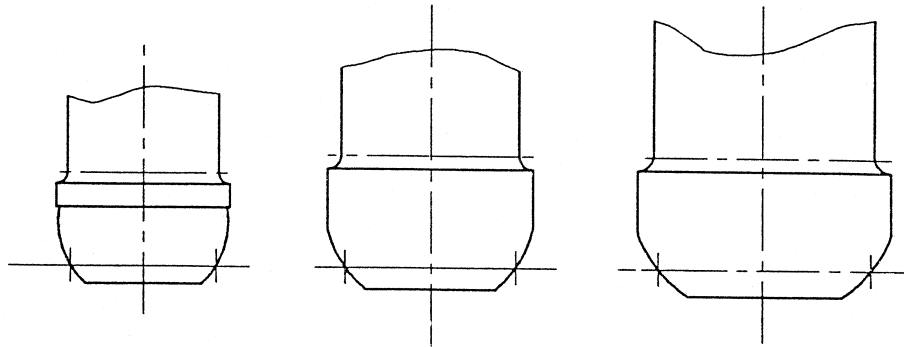

Figure 2
Table 1

Dimensional code	Tube		A +0,2 -0,1	B +0,2 0	C 0 -0,1	D 0 -0,1	E ±0,2	F ±0,2	G 0 -0,2	H ±0,5	J ±0,5	K ±0,5	L ±0,5	M +0,1 0
	Nominal diameter	Thickness												
040060	4	0,6	2,8	6	6,6	8,2	16,9	17,5	1,1	17,6	18,6	21,5	22,5	4,1
040080		0,8	2,4											
040100		1	2											
060060	6	0,6 ^a	4,8	7	9,9	11,5	18,6	18,5	1,5	19,7	20,2	25	24,9	6,1
060080		0,8	4,4											
060100		1	4											
080060	8	0,6 ^a	6,8	8,5	11,9	13,5	19,5	19,5	1,5	21,2	21,7	27	26,9	8,1
080080		0,8 ^a	6,4											
080100		1	6											
100060	10	0,6	8,8	8,5	13,5	15,5	20,6	22,5	1,5	22,7	25,2	28,5	31,1	10,1
100080		0,8 ^a	8,4											
100100		1 ^a	8											
120060	12	0,6 ^a	10,8	8,5	15,5	17,5	21,6	23,5	1,5	24,3	26,7	30,6	33,1	12,1
120080		0,8	10,4											
120100		1	10											
140060	14	0,6	12,8	8,5	17,5	19,5	22,6	25	1,5	25,8	28,7	32,6	35,6	14,1
140080		0,8 ^a	12,4											
140100		1 ^a	12											
160060	16	0,6 ^a	14,8	8,5	19,5	21,5	23,6	26	1,5	27,3	30,2	34,6	37,6	16,1
160080		0,8	14,4											
160100		1 ^a	14											
180060	18	0,6	16,8	8,5	22,5	24,5	25,1	27	1,5	29,4	31,7	38	39,6	18,1
180080		0,8	16,4											
180100		1 ^a	16											
200060	20	0,6 ^a	18,8	8,5	25,5	27,5	26,6	30	1,5	31,4	35,2	40,5	43,6	20,1
200080		0,8	18,4											
200100		1	18											
250080	25	0,8 ^a	23,4	8,5	31,5	33,5	29,6	33,9	1,5	35,8	40,3	45,5	50	25,1
250100		1	23											

Table 1 (concluded)

Dimensional code	Tube		N +0,1 0	P	Q +0,1 0	S +0,1 0	T +0,1 0	U + 0,15 - 0,05	V +0,1 0	W ± 0,2	X 0 -0,2	Y 0 -0,2	AA 0 -0,5	AB 0 -0,5	AC 0 -0,5
	Nominal diameter	Thickness													
040060	4	0,6	4,9	6,2	4	0,7	1,4	3,6	0,9	5	8	2,6	3	3	3
040080		0,8	5,1												
040100		1													
060060	6	0,6 ^a	6,9	9	6	0,7	1,4	5,25		7	10	3	3	3	3
060080		0,8	7,1												
060100		1													
080060	8	0,6 ^a	8,9	11	8	0,7	1,4	6,5		9	12	2,5	4	4	4
080080		0,8 ^a	9,1												
080100		1													
100060	10	0,6	10,9	13	10	0,7	1,4	7,5		11	14	2,1	4,5	5	4,5
100080		0,8 ^a	11,1												
100100		1 ^a													
120060	12	0,6 ^a	12,9	15	12	0,7	1,4	8,75		13	17	-	5,5	5,5	5,5
120080		0,8	13,1												
120100		1													
140060	14	0,6	14,9	17	14	0,8	1,6	9,75	1,1	15	19	-	6	6	6
140080		0,8 ^a	15,1												
140100		1 ^a													
160060	16	0,6 ^a	16,9	19	16	0,8	1,6	11	1,1	17	22	-	7	6	7
160080		0,8	17,1												
160100		1 ^a													
180060	18	0,6	18,9	21,6	18	0,9	1,8	12,5		19	-	6	6	6	6
180080		0,8	19,1												
180100		1 ^a													
200060	20	0,6 ^a	20,9	24,2	20	0,9	1,8	14		21	24	-	7	7	7
200080		0,8	21,1												
200100		1													
250080	25	0,8 ^a	26,1	29,8	25	1	2	17		26	26	-	7	7	7
250100		1													

^a Fitting end welded in accordance with EN 2656