

INTERNATIONAL STANDARD

**ISO
6263**

Second edition
1997-04-15

Hydraulic fluid power — Compensated flow-control valves — Mounting surfaces

iTeh STANDARD PREVIEW

Transmissions hydrauliques — Régulateurs de débit — Plan de pose
(standards.iteh.ai)

ISO 6263:1997

<https://standards.iteh.ai/catalog/standards/sist/4c2eabd1-2a90-42aa-b2ac-6a35dd9d5308/iso-6263-1997>



Reference number
ISO 6263:1997(E)

Foreword

ISO (the International Organization for Standardization) is a worldwide federation of national standards bodies (ISO member bodies). The work of preparing International Standards is normally carried out through ISO technical committees. Each member body interested in a subject for which a technical committee has been established has the right to be represented on that committee. International organizations, governmental and non-governmental, in liaison with ISO, also take part in the work. ISO collaborates closely with the International Electrotechnical Commission (IEC) on all matters of electrotechnical standardization.

Draft International Standards adopted by the technical committees are circulated to the member bodies for voting. Publication as an International Standard requires approval by at least 75 % of the member bodies casting a vote.

International Standard ISO 6263 was prepared by Technical Committee ISO/TC 131, *Fluid power systems*, Subcommittee SC 5, *Control products*.

This second edition cancels and replaces the first edition (ISO 6263:1987), which has been technically revised.

Annex A of this International Standard is for information only.

© ISO 1997

All rights reserved. Unless otherwise specified, no part of this publication may be reproduced or utilized in any form or by any means, electronic or mechanical, including photocopying and microfilm, without permission in writing from the publisher.

International Organization for Standardization
Case postale 56 • CH-1211 Genève 20 • Switzerland
Internet central@iso.ch
X.400 c=ch; a=400net; p=iso; o=isocs; s=central

Printed in Switzerland

Introduction

In hydraulic fluid power systems, power is transmitted and controlled through a liquid under pressure with an enclosed circuit. Typical components found in such systems are hydraulic valves. The devices control flow direction, pressure or flow rate of liquids in the enclosed circuit.

iTeh STANDARD PREVIEW (standards.iteh.ai)

[ISO 6263:1997](https://standards.iteh.ai/catalog/standards/sist/4c2eabd1-2a90-42aa-b2ac-6a35dd9d5308/iso-6263-1997)

<https://standards.iteh.ai/catalog/standards/sist/4c2eabd1-2a90-42aa-b2ac-6a35dd9d5308/iso-6263-1997>

iTeh STANDARD PREVIEW
This page intentionally left blank
(standards.iteh.ai)

[ISO 6263:1997](https://standards.iteh.ai/catalog/standards/sist/4c2eabd1-2a90-42aa-b2ac-6a35dd9d5308/iso-6263-1997)

<https://standards.iteh.ai/catalog/standards/sist/4c2eabd1-2a90-42aa-b2ac-6a35dd9d5308/iso-6263-1997>

Hydraulic fluid power — Compensated flow-control valves — Mounting surfaces

1 Scope

This International Standard specifies the dimensions and other data relating to surfaces on which hydraulic compensated flow-control valves are mounted in order to ensure interchangeability.

It applies to mounting surfaces for hydraulic compensated flow-control valves which represent current practice; they are generally applicable to industrial equipment.

iTeh STANDARD PREVIEW
(standards.iteh.ai)

2 Normative references

The following standards contain provisions which, through reference in this text, constitute provisions of this International Standard. At the time of publication the editions indicated were valid. All standards are subject to revision, and parties to agreements based on this International Standard are encouraged to investigate the possibility of applying the most recent editions of the standards indicated below. Members of IEC and ISO maintain registers of currently valid International Standards.

ISO 468:1982, *Surface roughness — Parameters, their values and general rules for specifying requirements.*

ISO 1101:1983, *Technical drawings — Geometrical tolerancing — Tolerancing of form, orientation, location, and run-out — Generalities, definitions, symbols, indications on drawings.*

ISO 1219-1:1991, *Fluid power systems and components — Graphic symbols and circuit diagrams — Part 1: Graphic symbols.*

ISO 1302:1992, *Technical drawings — Method of indicating surface texture.*

ISO 4401:1994, *Hydraulic fluid power — Four-port directional control valves — Mounting surfaces.*

ISO 5598:1985, *Fluid power systems and components — Vocabulary.*

ISO 5783:1995, *Hydraulic fluid power — Code for identification of valve mounting surfaces and cartridge valve cavities.*

3 Definitions

For the purposes of this International Standard, the definitions given in ISO 5598 apply.

4 Symbols

4.1 For the purposes of this International Standard, the following symbols apply:

- a) A, B, L, P, T and V designate ports;
- b) F_1 , F_2 , F_3 and F_4 designate threaded holes for fixing screws;
- c) G, G_1 and G_2 designate the location of pin holes;
- d) D designates the fixing screw diameter;
- e) r_{\max} designates mounting surface edge radius.

4.2 The graphical symbols used in figures 2, 4, 6, 8, 10, 12, 14 and 16 are in accordance with ISO 1219-1.

4.3 The code system used in this International Standard is defined in ISO 5783.

5 Tolerances

5.1 The following values shall be applied to the mounting surface, i.e. that area within the chain thick lines:

- surface roughness: $R_a \leq 0,8 \mu\text{m}$ (see ISO 468 and ISO 1302);
- surface flatness: 0,01 mm over a distance of 100 mm (see ISO 1101);
- tolerance for diameters of locating pin holes: H12.

5.2 With respect to the origin the following tolerances shall be complied with along x and y axes:

- pin holes: $\pm 0,1$ mm;
- screw holes: $\pm 0,1$ mm;
- port holes: $\pm 0,2$ mm.

iTeh STANDARD PREVIEW
(standards.iteh.ai)
<https://standards.iteh.ai/catalog/standards/sist/4c2eabd1-2a90-42aa-b2ac-6a35dd9d5308/iso-6263-1997>

For other dimensions, see the figures.

6 Dimensions

6.1 Mounting surface dimensions for hydraulic compensated flow-control valves shall be selected from the figures specified in 6.2 to 6.9.

6.2 Mounting surface dimensions for compensated flow-control valves with main ports of 4,5 mm maximum port diameter (code: 6263-02-01-*-97) are given in figure 1.

6.3 Mounting surface dimensions for compensated flow-control valves with main ports of 7,5 mm maximum port diameter (code: 6263-03-03-*-97) are given in figure 3.

6.4 Mounting surface dimensions for compensated flow-control valves with main ports of 14,7 mm maximum port diameter (code: 6263-06-05-*-97) are given in figure 5.

6.5 Mounting surface dimensions for compensated flow-control valves with main ports of 14,7 mm maximum port diameter (code: 6263-06-07-*-97) are given in figure 7.

6.6 Mounting surface dimensions for compensated flow-control valves with main ports of 17,5 mm maximum port diameter (code: 6263-07-09-*-97) are given in figure 9.

6.7 Mounting surface dimensions for compensated flow-control valves with main ports of 17,5 mm maximum port diameter (code: 6263-07-11-*-97) are given in figure 11.

6.8 Mounting surface dimensions for compensated flow-control valves with main ports of 23,4 mm maximum port diameter (code: 6263-08-13-*-97) are given in figure 13.

6.9 Mounting surface dimensions for compensated flow-control valves with main ports of 23,4 mm maximum port diameter (code: 6263-08-15-*-97) are given in figure 15.

7 Port marking

7.1 The port symbols for compensated flow-control valves shall be selected from the figures specified in 7.2 to 7.9.

7.2 Port symbols for compensated flow-control valves with main ports of 4,5 mm maximum port diameter (code: 6263-02-01-*-97) are given in figure 2.

7.3 Port symbols for compensated flow-control valves with main ports of 7,5 mm maximum port diameter (code: 6263-03-03-*-97) are given in figure 4.

7.4 Port symbols for compensated flow-control valves with two main ports of 14,7 mm maximum port diameter (code: 6263-06-05-*-97) are given in figure 6.

7.5 Port symbols for compensated flow-control valves with three main ports of 14,7 mm maximum port diameter (code: 6263-06-07-*-97) are given in figure 8.

7.6 Port symbols for compensated flow-control valves with two main ports of 17,5 mm maximum port diameter (code: 6263-07-09-*-97) are given in figure 10.

7.7 Port symbols for compensated flow-control valves with three main ports of 17,5 mm maximum port diameter (code: 6263-07-11-*-97) are given in figure 12.

7.8 Port symbols for compensated flow-control valves with two main ports of 23,4 mm maximum port diameter (code: 6263-08-13-*-97) are given in figure 14.

7.9 Port symbols for compensated flow-control valves with three main ports of 23,4 mm maximum port diameter (code: 6263-08-15-*-97) are given in figure 16.

8 Modular stack valves

For modular stack valves, the mounting surfaces and ports marking given in ISO 4401 shall be used.

9 Working pressure

For indication of the maximum limit of the working pressure, see note 1 in the figures 1, 3, 5, 7, 9, 11, 13 and 15.

10 Identification statement (Reference to this International Standard)

Use the following statement in test reports, catalogues and sales literature when electing to comply with this International Standard:

“Mounting surface dimensions conform to ISO 6263:1997, *Hydraulic fluid power — Compensated flow-control valves — Mounting surfaces.*”

Code: 6263-02-01-*-97

Dimensions in millimetres

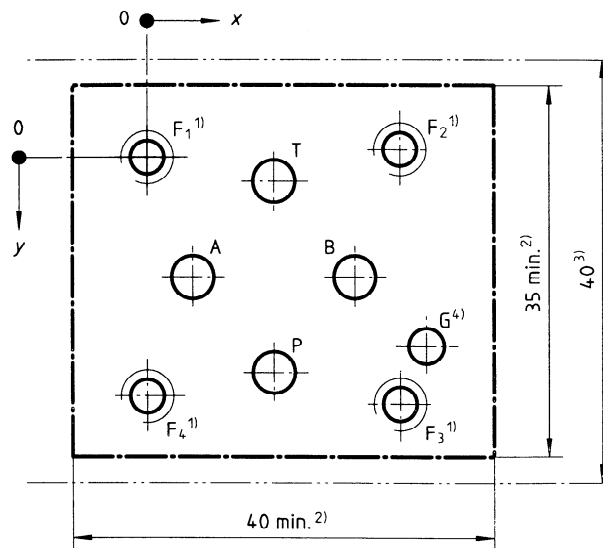

1) The minimum thread depth is 1,5 times the screw diameter, D . The recommended full thread depth is $2D + 6$ mm to facilitate interchangeability of valves and to reduce the number of fixing screw lengths. The recommended engagement of fixing screw thread for ferrous mountings is $1,25D$.

2) The dimensions specifying the area within the chain thick lines are the minimum dimensions for the mounting surface. The corners of the rectangle may be radiused to a maximum radius, r_{max} , equal to the thread diameter of the fixing screws. Along each axis the fixing holes are at equal distances to the mounting surface edges.

3) This dimension gives the minimum space required for a valve with this mounting surface. The dimension is also the minimum distance from centreline to centreline of two identical mounting surfaces placed on a manifold block. The valve manufacturer's attention is drawn to the fact that no part of the width of the complete valve assembly shall exceed this dimension.

4) Blind hole in the mounting surface to accommodate the locating pin on the valves. The minimum depth is 4 mm.

NOTES

- 1 The supplier shall stipulate the maximum working pressure for subplates and manifold blocks.
- 2 See figure 2 for graphical symbols.

Axis	P	A	T	B	G	F ₁	F ₂	F ₃	F ₄
	∅ 4,5 max.	∅ 4,5 max.	∅ 4,5 max.	∅ 4,5 max.	∅ 3,4 max.	M5	M5	M5	M5
x	12	4,3	12	19,7	25,5	0	24	24	0
y	20,25	11,25	2,25	11,25	17,75	0	-0,75	23,25	22,5

Figure 1 — Mounting surface for compensated flow-control valves with main ports of 4,5 mm maximum port diameter (size 02)

Option according to ISO 5783	0	1
Description	Internal drain	External drain
Compensated flow-control valve with two main ports		
Compensated flow-control valve with by-pass check valve with two main ports		
Compensated flow-control valve with three main ports		

Figure 2 — Compensated flow-control valves with main ports of 4,5 mm maximum port diameter (code: 6263-02-01-*-97)

Code: 6263-03-03-*-97

Dimensions in millimetres

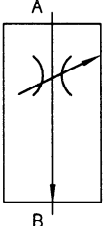
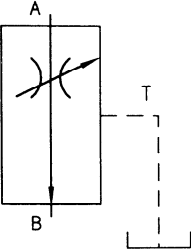
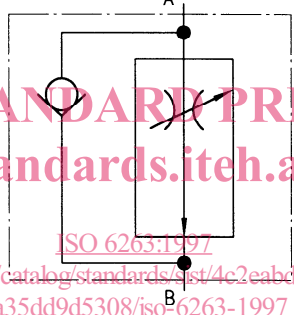
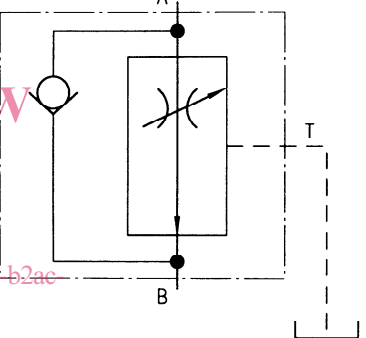
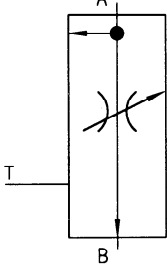
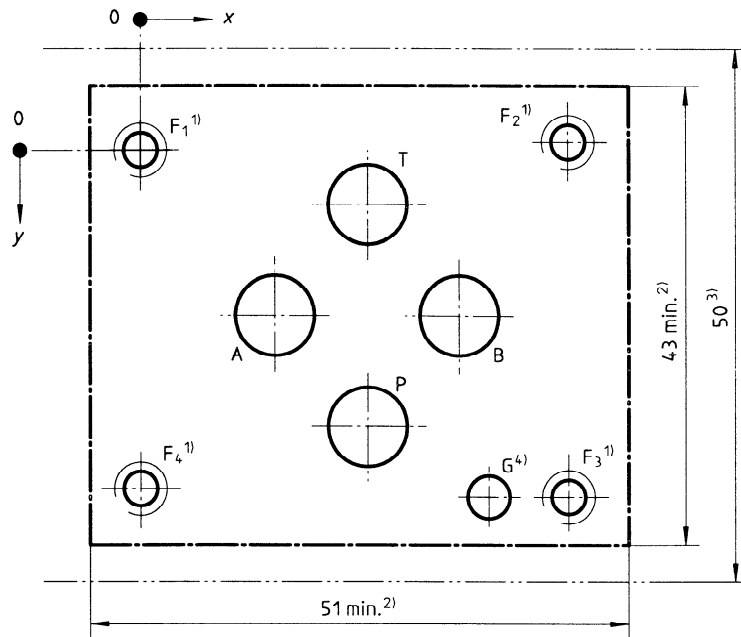

1) The minimum thread depth is 1,5 times the screw diameter, D . The recommended full thread depth is $2D + 6$ mm to facilitate interchangeability of valves and to reduce the number of fixing screw lengths. The recommended engagement of fixing screw thread for ferrous mountings is $1,25D$.

2) The dimensions specifying the area within the chain thick lines are the minimum dimensions for the mounting surface. The corners of the rectangle may be radiused to a maximum radius, r_{max} , equal to the thread diameter of the fixing screws. Along each axis the fixing holes are at equal distances to the mounting surface edges.

3) This dimension gives the minimum space required for a valve with this mounting surface. The dimension is also the minimum distance from centreline to centreline of two identical mounting surfaces placed on a manifold block.

The valve manufacturer's attention is drawn to the fact that no part of the width of the complete valve assembly shall exceed this dimension.

4) Blind hole in the mounting surface to accomodate the locating pin on the valves. The minimum depth is 4 mm.

NOTES

1 The supplier shall stipulate the maximum working pressure for subplates and manifold blocks.

2 See figure 4 for graphical symbols.

Axis	P	A	T	B	G	F ₁	F ₂	F ₃	F ₄
	∅ 7,5 max.	∅ 7,5 max.	∅ 7,5 max.	∅ 7,5 max.	∅ 4	M5	M5	M5	M5
x	21,5	12,7	21,5	30,2	33	0	40,5	40,5	0
y	25,9	15,5	5,1	15,5	31,75	0	- 0,75	31,75	31

Figure 3 — Mounting surface for compensated flow-control valves with main ports of 7,5 mm maximum port diameter (size 03)

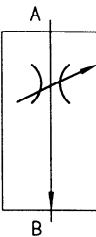
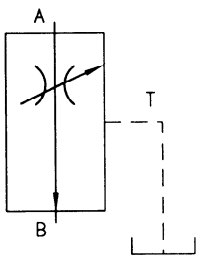
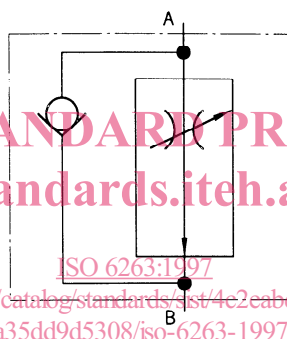
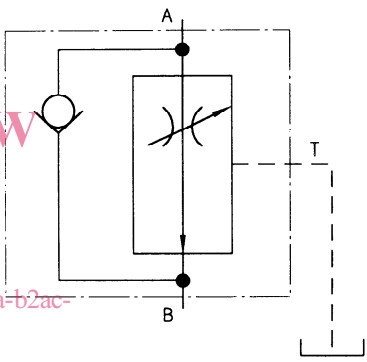
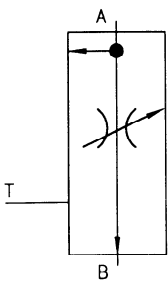
Option according to ISO 5783	0	1
Description	Internal drain	External drain
Compensated flow-control valve with two main ports		
Compensated flow-control valve with by-pass check valve with two main ports		
Compensated flow-control valve with three main ports		

Figure 4 — Compensated flow-control valves with main ports of 7,5 mm maximum port diameter (code: 6263-03-03-* -97)