**Fluidna tehnika - Pnevmatika - Regulatorji tlaka in regulatorji tlaka s filtri - 1. del:
Glavne značilnosti, ki morajo biti navedene v dokumentaciji dobaviteljev in načini
označevanja**

Pneumatic fluid power -- Compressed air pressure regulators and filter-regulators -- Part
1: Main characteristics to be included in literature from suppliers and product-marking
requirements

iTeh STANDARD PREVIEW
(standards.iteh.ai)

Transmissions pneumatiques -- Régulateurs de pression et filtre-régulateurs pour air
comprimé -- Partie 1: Principales caractéristiques à inclure dans la documentation des
fournisseurs et exigences de marquage du produit

Ta slovenski standard je istoveten z: ISO 6953-1:2000

ICS:

23.060.40	Tlačni regulatorji	Pressure regulators
23.140	Kompresorji in pnevmatični stroji	Compressors and pneumatic machines

SIST ISO 6953-1:2001

en

iTeh STANDARD PREVIEW
(standards.iteh.ai)

SIST ISO 6953-1:2001

<https://standards.iteh.ai/catalog/standards/sist/81cdf6-f756-464f-a828-05ad02665bbf/sist-iso-6953-1-2001>

INTERNATIONAL STANDARD

ISO
6953-1

Second edition
2000-09-01

Pneumatic fluid power — Compressed air pressure regulators and filter-regulators —

Part 1:

Main characteristics to be included in literature from suppliers and product-marking requirements

*Transmissions pneumatiques — Régulateurs de pression
et filtre-régulateurs pour air comprimé —*

*Partie 1: Principales caractéristiques à inclure dans la documentation des
fournisseurs et exigences de marquage du produit*



Reference number
ISO 6953-1:2000(E)

© ISO 2000

PDF disclaimer

This PDF file may contain embedded typefaces. In accordance with Adobe's licensing policy, this file may be printed or viewed but shall not be edited unless the typefaces which are embedded are licensed to and installed on the computer performing the editing. In downloading this file, parties accept therein the responsibility of not infringing Adobe's licensing policy. The ISO Central Secretariat accepts no liability in this area.

Adobe is a trademark of Adobe Systems Incorporated.

Details of the software products used to create this PDF file can be found in the General Info relative to the file; the PDF-creation parameters were optimized for printing. Every care has been taken to ensure that the file is suitable for use by ISO member bodies. In the unlikely event that a problem relating to it is found, please inform the Central Secretariat at the address given below.

iTeh STANDARD PREVIEW (standards.iteh.ai)

SIST ISO 6953-1:2001

<https://standards.iteh.ai/catalog/standards/sist/81cdf6-f756-464f-a828-05ad02665bbf/sist-iso-6953-1-2001>

© ISO 2000

All rights reserved. Unless otherwise specified, no part of this publication may be reproduced or utilized in any form or by any means, electronic or mechanical, including photocopying and microfilm, without permission in writing from either ISO at the address below or ISO's member body in the country of the requester.

ISO copyright office
Case postale 56 • CH-1211 Geneva 20
Tel. + 41 22 749 01 11
Fax + 41 22 749 09 47
E-mail copyright@iso.ch
Web www.iso.ch

Printed in Switzerland

Foreword

ISO (the International Organization for Standardization) is a worldwide federation of national standards bodies (ISO member bodies). The work of preparing International Standards is normally carried out through ISO technical committees. Each member body interested in a subject for which a technical committee has been established has the right to be represented on that committee. International organizations, governmental and non-governmental, in liaison with ISO, also take part in the work. ISO collaborates closely with the International Electrotechnical Commission (IEC) on all matters of electrotechnical standardization.

International Standards are drafted in accordance with the rules given in the ISO/IEC Directives, Part 3.

Draft International Standards adopted by the technical committees are circulated to the member bodies for voting. Publication as an International Standard requires approval by at least 75 % of the member bodies casting a vote.

Attention is drawn to the possibility that some of the elements of this part of ISO 6953 may be the subject of patent rights. ISO shall not be held responsible for identifying any or all such patent rights.

International Standard ISO 6953-1 was prepared by Technical Committee ISO/TC 131, *Fluid power systems*, Subcommittee SC 5, *Control products and components*.

This second edition cancels and replaces the first edition (ISO 6953-1:1990), which has been technically revised.

ISO 6953 consists of the following parts, under the general title *Pneumatic fluid power — Compressed air pressure regulators and filter-regulators*:

- Part 1: Main characteristics to be included in literature from suppliers and product-marking requirements
- Part 2: Test methods to determine the main characteristics to be included in literature from suppliers

Introduction

In pneumatic fluid power systems, power is transmitted and controlled through air under pressure circulating within a circuit. Where reduction and regulation of the pressure is desired, the regulators and filter-regulators are components designed to maintain the compressed air pressure approximately constant.

iTeh STANDARD PREVIEW (standards.iteh.ai)

[SIST ISO 6953-1:2001](https://standards.iteh.ai/catalog/standards/sist/81cdf6-f756-464f-a828-05ad02665bbf/sist-iso-6953-1-2001)

<https://standards.iteh.ai/catalog/standards/sist/81cdf6-f756-464f-a828-05ad02665bbf/sist-iso-6953-1-2001>

Pneumatic fluid power — Compressed air pressure regulators and filter-regulators —

Part 1:

Main characteristics to be included in literature from suppliers and product-marking requirements

1 Scope

This part of ISO 6953 specifies the characteristics of compressed air pressure regulators to be included in literature from their suppliers. It also applies to filter-regulators.

In addition, it specifies the product marking requirements for pressure regulators and filter-regulators.

This part of ISO 6953 is applicable to compressed air pressure regulators with a rated inlet pressure of up to 2 500 kPa [25 bar¹⁾] and an outlet adjustment pressure of up to 1 600 kPa (16 bar), and to filter-regulators with rated inlet and outlet pressures of up to 1 600 kPa (16 bar), in which the major contaminants are removed by mechanical means. The maximum temperature is 80 °C for regulators and filter-regulators and applies to materials of construction that are light alloys (aluminium, etc.), zinc die-casting alloys, brass, steel and plastic.

The rated pressure should be selected from the preferred pressures listed in ISO 2944.

2 Normative references

The following normative documents contain provisions which, through reference in this text, constitute provisions of this part of ISO 6953. For dated references, subsequent amendments to, or revisions of, any of these publications do not apply. However, parties to agreements based on this part of ISO 6953 are encouraged to investigate the possibility of applying the most recent editions of the normative documents indicated below. For undated references, the latest edition of the normative document referred to applies. Members of ISO and IEC maintain registers of currently valid International Standards.

ISO 2944:2000, *Fluid power systems and components — Nominal pressures*.

ISO 5598:1985, *Fluid power systems and components — Vocabulary*.

ISO 5782-2:1997, *Pneumatic fluid power — Compressed air filters — Part 2: Test methods to determine the main characteristics to be included in supplier's literature*.

ISO 6953-2:2000, *Pneumatic fluid power — Compressed air pressure regulators and filter-regulators — Part 2: Test methods to determine the main characteristics to be included in literature from suppliers*.

ISO 11727:1999, *Pneumatic fluid power — Identification of ports and control mechanisms of control valves and other components*.

1) 1 bar = 0,1 MPa = 10⁵ Pa; 1 MPa = 1 N/mm².

ISO 6953-1:2000(E)**3 Terms and definitions**

For the purposes of this part of ISO 6953, the terms and definitions given in ISO 5598 and the following apply.

3.1**rated pressure**

pressure, confirmed through testing, at which a component or piping is designed to operate for a number of repetitions sufficient to assure adequate service life

3.2**compressed air pressure regulator**

component designed to maintain compressed air pressure approximately constant within an enclosed circuit despite variations in operating flow rate and inlet pressure

3.3**relieving pressure regulator**

pressure regulator equipped with an unloading device that will open if the outlet pressure exceeds the original setting by a sufficient degree, and exhaust a limited flow rate of air from the outlet circuit to the atmosphere

3.4**filter-regulator**

device that combines the filter and regulator onto one body as a single unit

NOTE In such a device, the filter is always on the upstream side of the regulator.

3.5**forward flow characteristics curve**

graphical representation of the change in outlet (regulated) pressure with changes in the air flow rate while the inlet pressure is held constant

3.6**pressure regulation characteristics curve**

graphical representation of outlet (regulated) pressure variation caused by changes in inlet (supply) pressure, at an approximately constant air flow rate

3.7**relief flow characteristics curve**

graphical representation of the relationship between relief flow rate and outlet (regulated) pressure above the regulator setting while the inlet pressure is held constant

4 Technical requirements**4.1 General**

Descriptive literature covering compressed air pressure regulators and filter-regulators shall include the characteristics given in 4.2 and 4.3.

4.2 General characteristics**4.2.1 General dimensions**

The dimensions shown in Figure 1 shall be given in millimetres. For ports, see 4.2.2.

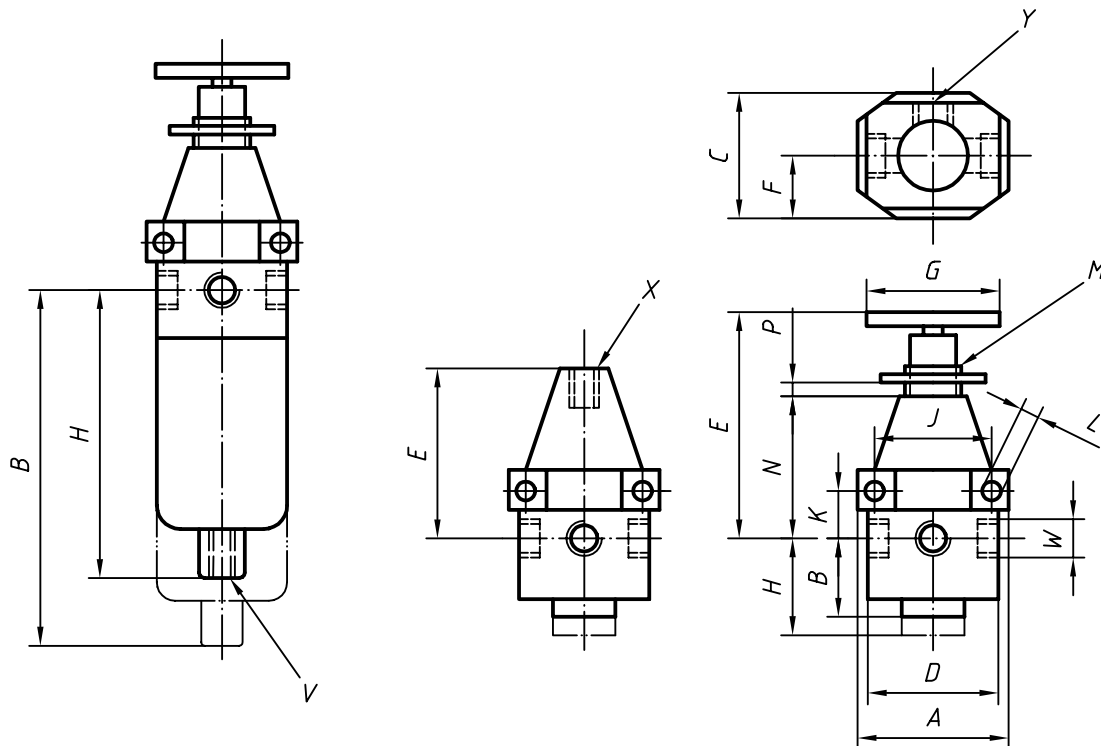
**Key**

- iTeh STANDARD PREVIEW**
(standards.iteh.ai)
- A** Maximum overall width
- B** Maximum installation height below the port centreline
- C** Maximum overall depth, excluding pressure gauge
- D** Distance between the faces of the compressed air connection (inlet/outlet)
- E** Maximum height above the port centreline
- F^a** Maximum installation depth from the port centreline
- G** Maximum dimension of the outlet pressure adjusting device.
- H** Minimum clearance from the port centreline to permit dismantling
- J^b** Distance between mounting holes
- K^b** Distance between the port centreline and mounting holes
- L^b** Minimum diameter and length of mounting holes or recommended mounting bolts
- M** Panel mounting thread
- N** Panel mounting height above the port centreline
- P** Maximum panel thickness
- V** Drain hole description
- W** Port description
- X** Pilot port description
- Y** Pressure gauge port description
- ^a Applies also for mounting brackets.
- ^b Dimensions *J*, *K* and *L* shall be indicated only if the device has provisions for mounting.

Figure 1 — Dimensions of compressed air regulators and filter-regulators