Aerospace series - Bolts, double hexagon head, normal shank, long thread, in titanium alloy TI-P64001, MoS2 coated - Classification: 1 100 MPa (at ambient temperature)/350 °C

Aerospace series - Bolts, double hexagon head, normal shank, long thread, in titanium alloy TI-P64001, MoS2 coated - Classification: 1 100 MPa (at ambient temperature)/350 °C

iTeh STANDARD PREVIEW
(standards.iteh.ai)

Série aérospatiale - Vis a tete bihexagonale, tige normale, filetage long, en alliage de titane TI-P63, revetues MoS2 - Classification: 1 100 MPa (a température ambiante)/350° C

Ta slovenski standard je istoveten z: EN 3907:2003

ICS:

49.030.20 Sorniki, vijaki, stebelni vijaki Bolts, screws, studs

SIST EN 3907:2004

en

iTeh STANDARD PREVIEW
(standards.iteh.ai)

SIST EN 3907:2004

<https://standards.iteh.ai/catalog/standards/sist/d3122b87-4250-4bf9-8e15-b40d651011a8/sist-en-3907-2004>

EUROPEAN STANDARD
NORME EUROPÉENNE
EUROPÄISCHE NORM

EN 3907

February 2003

ICS 49.030.20

English version

Aerospace series - Bolts, double hexagon head, normal shank,
long thread, in titanium alloy TI-P64001, MoS₂ coated -
Classification: 1 100 MPa (at ambient temperature)/350 °C

This European Standard was approved by CEN on 14 September 2002.

CEN members are bound to comply with the CEN/CENELEC Internal Regulations which stipulate the conditions for giving this European Standard the status of a national standard without any alteration. Up-to-date lists and bibliographical references concerning such national standards may be obtained on application to the Management Centre or to any CEN member.

This European Standard exists in three official versions (English, French, German). A version in any other language made by translation under the responsibility of a CEN member into its own language and notified to the Management Centre has the same status as the official versions.

CEN members are the national standards bodies of Austria, Belgium, Czech Republic, Denmark, Finland, France, Germany, Greece, Hungary, Iceland, Ireland, Italy, Luxembourg, Malta, Netherlands, Norway, Portugal, Slovak Republic, Spain, Sweden, Switzerland and United Kingdom.

[SIST EN 3907:2004](https://standards.iteh.ai/catalog/standards/sist/d3122b87-4250-4bf9-8e15-b40d651011a8/sist-en-3907-2004)

<https://standards.iteh.ai/catalog/standards/sist/d3122b87-4250-4bf9-8e15-b40d651011a8/sist-en-3907-2004>



EUROPEAN COMMITTEE FOR STANDARDIZATION
COMITÉ EUROPÉEN DE NORMALISATION
EUROPÄISCHES KOMITEE FÜR NORMUNG

Management Centre: rue de Stassart, 36 B-1050 Brussels

Contents

Foreword.....	3
1 Scope	3
2 Normative references	3
3 Required characteristics	4
3.1 Configuration – Dimensions – Tolerances – Masses.....	4
3.2 Materials.....	4
3.3 Surface treatment	4
4 Designation.....	9
5 Marking	9
6 Technical specification	9

iTeh STANDARD PREVIEW (standards.iteh.ai)

[SIST EN 3907:2004](https://standards.iteh.ai/catalog/standards/sist/d3122b87-4250-4bf9-8e15-b40d651011a8/sist-en-3907-2004)

<https://standards.iteh.ai/catalog/standards/sist/d3122b87-4250-4bf9-8e15-b40d651011a8/sist-en-3907-2004>

Foreword

This document EN 3907:2003 has been prepared by the European Association of Aerospace Manufacturers (AECMA).

After enquiries and votes carried out in accordance with the rules of this Association, this Standard has received the approval of the National Associations and the Official Services of the member countries of AECMA, prior to its presentation to CEN.

This European Standard shall be given the status of a national standard, either by publication of an identical text or by endorsement, at the latest by August 2003, and conflicting national standards shall be withdrawn at the latest by August 2003.

According to the CEN/CENELEC Internal Regulations, the national standards organizations of the following countries are bound to implement this European Standard : Austria, Belgium, Czech Republic, Denmark, Finland, France, Germany, Greece, Hungary, Iceland, Ireland, Italy, Luxembourg, Malta, Netherlands, Norway, Portugal, Slovakia, Spain, Sweden, Switzerland and United Kingdom.

iTeh STANDARD PREVIEW (standards.iteh.ai)

1 Scope

This standard specifies the characteristics of double hexagon headed bolts with normal shank and long thread in titanium alloy TI-P64001, MoS₂ coated for aerospace applications.

Classification: 1 100 MPa¹⁾ / 350 °C <https://standards.iteh.ai/catalog/standards/sist/d3122b87-4250-4bf9-8e15-b40d651011a8/sist-en-3907-2004>

2 Normative references

This European Standard incorporates by dated or undated reference, provisions from other publications. These normative references are cited at the appropriate places in the text, and the publications are listed hereafter. For dated references, subsequent amendments to or revisions of any of these publications apply to this European Standard only when incorporated in it by amendment or revision. For undated references the latest edition of the publication referred to applies (including amendments).

ISO 3353 *Aerospace - Lead and runout threads.*

ISO 4095 *Aerospace – Bihexagonal drives – Wrenching configuration – Metric series.*

ISO 5855-2 *Aerospace - MJ threads - Part 2 : Limit dimensions for bolts and nuts.*

EN 2424 *Aerospace series - Marking of aerospace products.*

EN 2491 *Aerospace series - Molybdenum disulphide dry lubricants - Coating methods.*

EN 3457 *Aerospace series - Titanium alloy TI-P63 - Not heat treated - Reference heat treatment :solution treated and aged - Grade 2 forging stock for fasteners - D ≤ 25 mm²⁾.*

1) Minimum tensile strength of the material at ambient temperature

2) Published as AECMA Prestandard at the date of publication of this standard

EN 3907:2003 (E)

- EN 3813 *Aerospace series – Titanium alloy TI-P64001 – Annealed – Bar and wire for forged fasteners – $D_e \leq 25 \text{ mm}^3$.*
- EN 3818 *Aerospace series - Bolts with MJ threads, in titanium alloy TI-P64001 - Classification: 1 100 MPa (at ambient temperature) - Technical specification ²⁾.*

3 Required characteristics**3.1 Configuration – Dimensions – Tolerances – Masses**

See Figure 1 and Tables 1 and 2. Dimensions and tolerances are in millimetres. They apply before MoS₂ coating.

3.2 Materials

EN 3457 or EN 3813

3.3 Surface treatment

EN 2491

iTeh STANDARD PREVIEW
(standards.iteh.ai)

[SIST EN 3907:2004](https://standards.iteh.ai/catalog/standards/sist/d3122b87-4250-4bf9-8e15-b40d651011a8/sist-en-3907-2004)

<https://standards.iteh.ai/catalog/standards/sist/d3122b87-4250-4bf9-8e15-b40d651011a8/sist-en-3907-2004>

3) In preparation at the date of publication of this standard

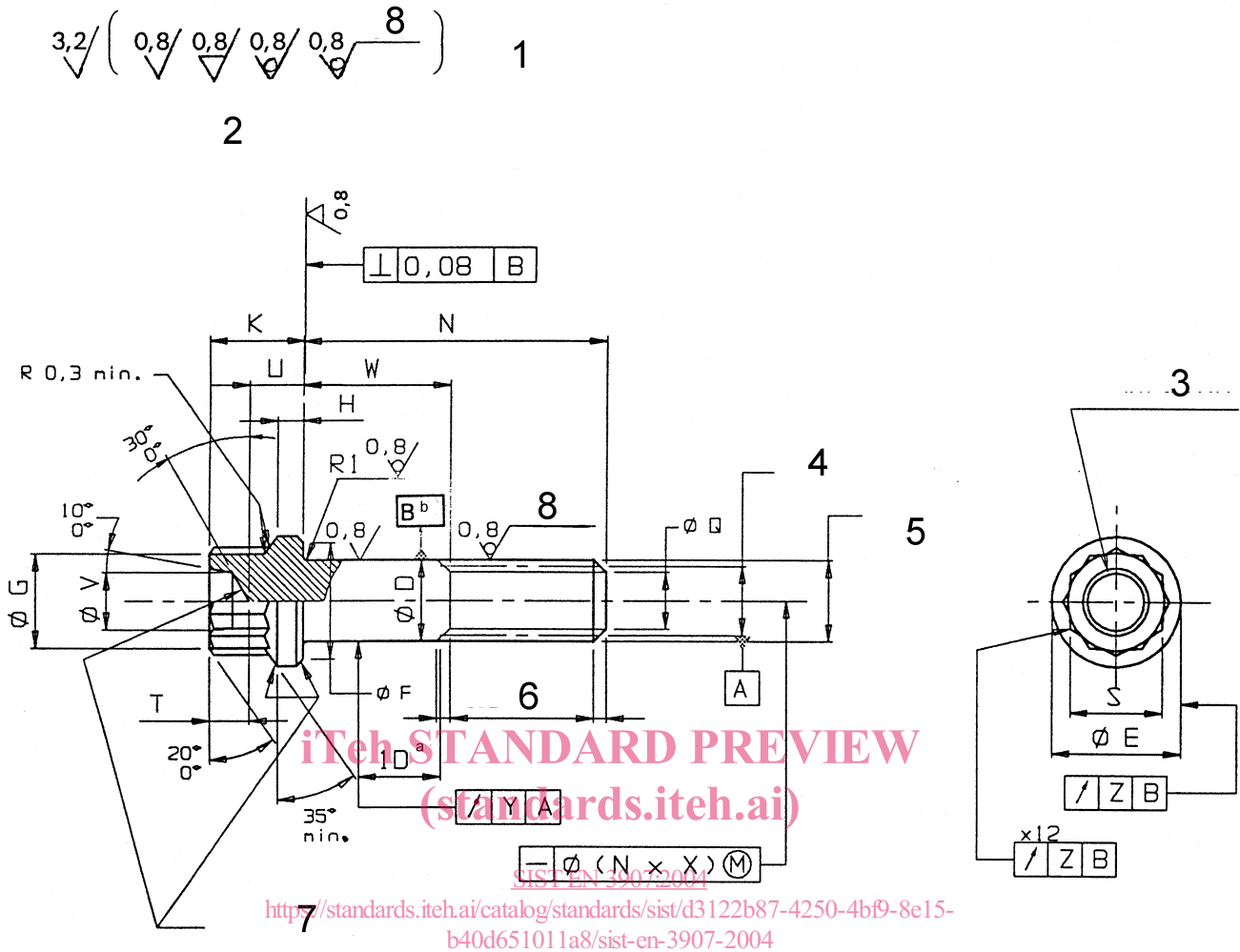

Key

- 1 Values apply before MoS₂ coating
 - 2 Remove sharp edges 0,1 to 0,4
 - 3 Marking
 - 4 Pitch diameter
 - 5 Thread
 - 6 Conforms to ISO 3353
 - 7 Shape in this area at manufacturer's option
- ^a When the length of the shank is less than one times the nominal value of the shank diameter D , the run-out is measured at a distance equal to half the actual shank length
- ^b For bolts having a shank length less than one times the nominal value of the shank diameter D , and for those threaded to head, the pitch diameter axis shall be used as the datum.

Figure 1

EN 3907:2003 (E)

Table 1

Thread ^a		<i>D</i> h12	<i>E</i> max.	<i>F</i> min.	<i>G</i> min.	<i>H</i> min.	<i>K</i> h15	<i>Q</i> ± 0,5	<i>R</i> ₁		<i>S</i> ^b	<i>T</i> min.	<i>U</i>		<i>V</i>		<i>X</i>	<i>Y</i>	<i>Z</i>
Code	Designation								max.	min.			max.	min.	max.	min.			
050	MJ5x0,8-4h6h	5	9,1	8,3	6,8	1	5,5	3,4	0,5	0,3	7	2	2,9	2,5	3,7	3,2	0,003	0,12	0,13
060	MJ6x1-4h6h	6	10,6	9,8	7,8	1,2	6	4,2	0,7	0,5	8	2,3	3,2	2,8	4,6	4,1		0,15	0,15
070	MJ7x1-4h6h	7	12,1	11,3	8,8	1,4	6,5	5,2			9	2,6	3,7	3,3	5,4	4,9		0,15	0,18
080	MJ8x1-4h6h	8	13,6	12,8	9,8	1,6	7	6,2			10	2,8	4,1	3,7	5,7	5,2		0,2	0,2
100	MJ10x1,25-4h6h	10	16,7	15,7	11,8	2	8	7,9	0,8	0,6	12	3,1	5,1	4,7	7,2	6,7	0,0025	0,25	0,25
120	MJ12x1,25-4h6h	12	19,9	18,8	13,7	2,4	9,2	9,8	0,9		14	3,5	6	5,6	8,5	8		0,18	0,3

^a In accordance with ISO 5855-2

^b Bihexagonal wrenching configuration in conformity with ISO 4095 over length T min.

iTeh STANDARD PREVIEW (standards.iteh.ai)

SIST EN 3907:2004

<https://standards.iteh.ai/catalog/standards/sist/d3122b87-4250-4bf9-8e15-b40d651011a8/sist-en-3907-2004>

Table 2

Length code	N ± 0,3	Thread code																	
		050			060			070			080			100			120		
		W		Mass ^a	W		Mass ^a	W		Mass ^a	W		Mass ^a	W		Mass ^a	W		Mass ^a
max.	min.		max.	min.		max.	min.		max.	min.		max.	min.		max.	min.			
008	8			1,78															
010	10			1,96															
012	12	2,1	1,7	2,13															
014	14			2,30	2,7	2,2													
016	16			2,48															
018	18			2,65															
020	20	4	2,5	2,83															
022	22	6	4,5	3,00	4	2,5													
024	24	8	6,5	3,18	6	4,5													
026	26	10	8,5	3,35	8	6,5													
028	28	12	10,5	3,53	10	8,5													
030	30	14	12,5	3,70	12	10,5													
032	32	16	14,5	3,88	14	12,5													
034	34	18	16,5	4,05	16	14,5													
036	36	20	18,5	4,23	18	16,5													
038	38	22	20,5	4,40	20	18,5													
040	40	24	22,5	4,58	22	20,5													
042	42	26	24,5	4,75	24	22,5													
044	44	28	26,5	4,93	26	24,5													
046	46	30	28,5	5,10	28	26,5													
048	48	32	30,5	5,27	30	28,5													
050	50	34	32,5	5,45	32	30,5													
052	52	36	34,5	5,62	34	32,5													
054	54	38	36,5	5,80	36	34,5													
056	56	40	38,5	5,97	38	36,5													
058	58	42	40,5	6,15	40	38,5													
060	60	44	42,5	6,32	42	40,5													
062	62	46	44,5	6,50	44	42,5													
064	64	48	46,5	6,67	46	44,5													
066	66	50	48,5	6,85	48	46,5													
068	68	52	50,5	7,02	50	48,5													
070	070	54	52,5	7,20	52	50,5													

(continued)