



SLOVENSKI STANDARD SIST EN 4015:2004

01-maj-2004

Aerospace series - Inserts, thickwall, self-locking - Installation and removal procedure

Aerospace series - Inserts, thickwall, self-locking - Installation and removal procedure

iTeh STANDARD PREVIEW
(standards.iteh.ai)

Ta slovenski standard je istoveten z: EN 4015:2003

<https://standards.iteh.ai/catalog/standards/sist/ba46677c-c84d-461f-82eb-395b697f680d/sist-en-4015-2004>

ICS:

49.030.30 Matice Nuts

SIST EN 4015:2004 **en**

iTeh STANDARD PREVIEW
(standards.iteh.ai)

[SIST EN 4015:2004](#)

<https://standards.iteh.ai/catalog/standards/sist/ba46677c-c84d-461f-82eb-395b697f680d/sist-en-4015-2004>

EUROPEAN STANDARD

EN 4015

NORME EUROPÉENNE

EUROPÄISCHE NORM

January 2003

ICS 49.030.30

English version

**Aerospace series - Inserts, thickwall, self-locking - Installation
and removal procedure**

This European Standard was approved by CEN on 2 June 2002.

CEN members are bound to comply with the CEN/CENELEC Internal Regulations which stipulate the conditions for giving this European Standard the status of a national standard without any alteration. Up-to-date lists and bibliographical references concerning such national standards may be obtained on application to the Management Centre or to any CEN member.

This European Standard exists in three official versions (English, French, German). A version in any other language made by translation under the responsibility of a CEN member into its own language and notified to the Management Centre has the same status as the official versions.

CEN members are the national standards bodies of Austria, Belgium, Czech Republic, Denmark, Finland, France, Germany, Greece, Hungary, Iceland, Ireland, Italy, Luxembourg, Malta, Netherlands, Norway, Portugal, Slovakia, Spain, Sweden, Switzerland and United Kingdom.

iTeh STANDARD PREVIEW
(standards.iteh.ai)

SIST EN 4015:2004
<https://standards.iteh.ai/catalog/standards/sist/ba46677c-c84d-461f-82eb-395b697f680d/sist-en-4015-2004>



EUROPEAN COMMITTEE FOR STANDARDIZATION
COMITÉ EUROPÉEN DE NORMALISATION
EUROPÄISCHES KOMITEE FÜR NORMUNG

Management Centre: rue de Stassart, 36 B-1050 Brussels

iTeh STANDARD PREVIEW
(standards.iteh.ai)

SIST EN 4015:2004

<https://standards.iteh.ai/catalog/standards/sist/ba46677c-c84d-461f-82eb-395b697f680d/sist-en-4015-2004>

iTeh STANDARD PREVIEW
(standards.iteh.ai)

SIST EN 4015:2004

<https://standards.iteh.ai/catalog/standards/sist/ba46677c-c84d-461f-82eb-395b697f680d/sist-en-4015-2004>

iTeh STANDARD PREVIEW
(standards.iteh.ai)

SIST EN 4015:2004

<https://standards.iteh.ai/catalog/standards/sist/ba46677c-c84d-461f-82eb-395b697f680d/sist-en-4015-2004>

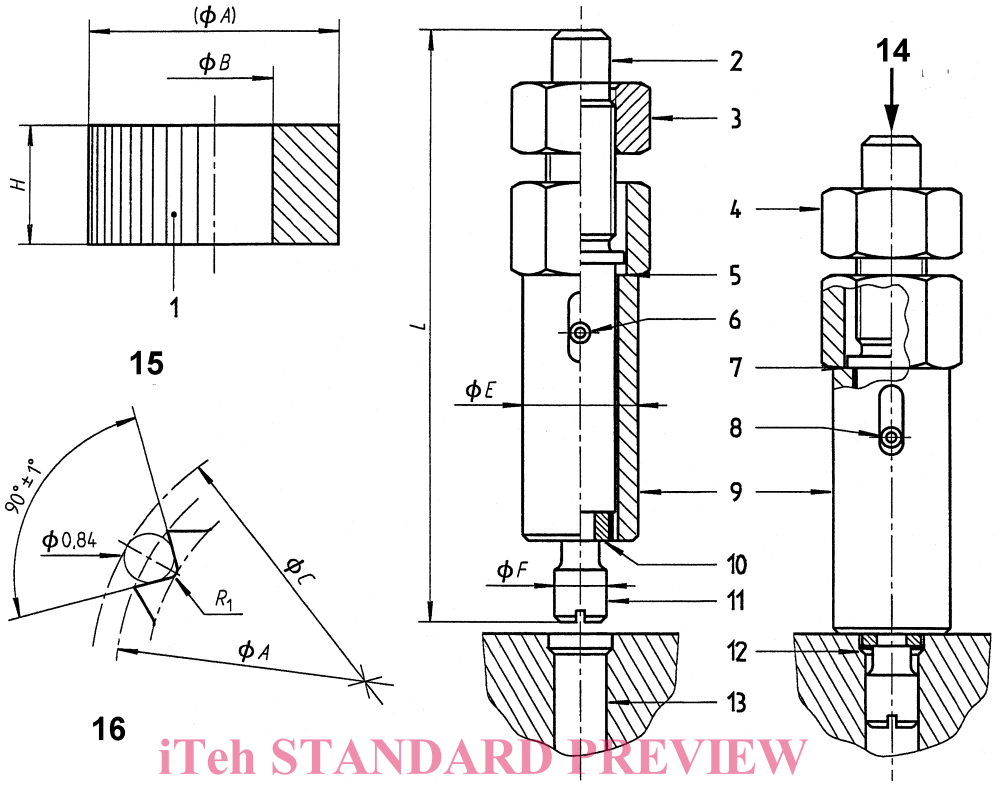

iTeh STANDARD PREVIEW
(standards.iteh.ai)

SIST EN 4015:2004

<https://standards.iteh.ai/catalog/standards/sist/ba46677c-c84d-461f-82eb-395b697f680d/sist-en-4015-2004>

iTeh STANDARD PREVIEW (standards.iteh.ai)

SIST EN 4015:2004

<https://standards.iteh.ai/catalog/standards/sist/ba46677c-c84d-461f-82eb-395b697f680d/sist-en-4015-2004>

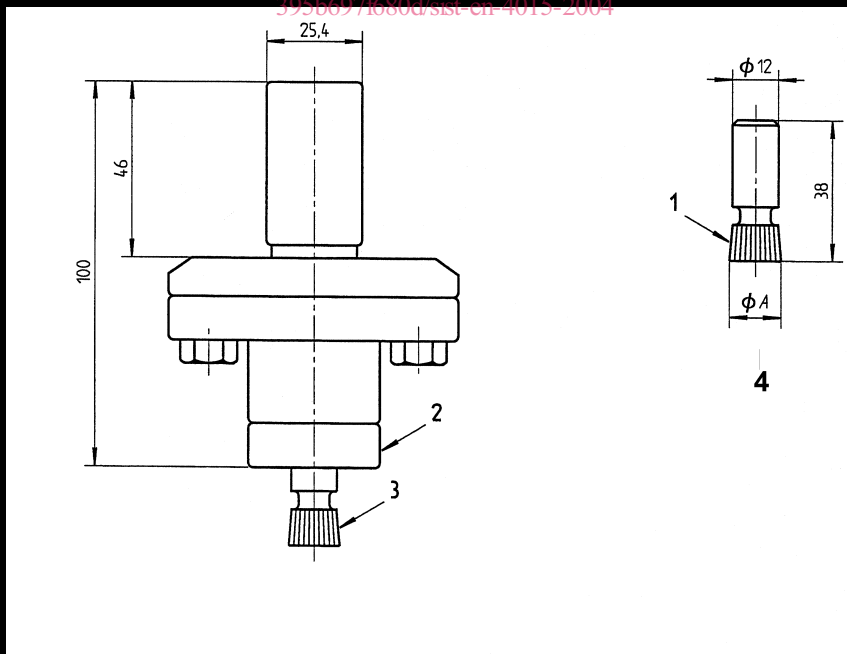

iTeh STANDARD PREVIEW (standards.iteh.ai)

SIST EN 4015:2004

<https://standards.iteh.ai/catalog/standards/sist/ba46677c-c84d-461f-82cb-395b697f680d/sist-en-4015-2004>

