

INTERNATIONAL
STANDARD

ISO
12098

First edition
1994-12-15

**Commercial vehicles with 24 V systems —
15-pole connectors between towing
vehicles and trailers — Dimensions and
contact allocation**

iTeh STANDARD PREVIEW
(standards.iteh.ai)

Véhicules utilitaires équipés d'un système électrique 24 V — Connecteurs à 15 contacts pour liaison entre le véhicule tracteur et le véhicule tracté — Dimensions et affectation des contacts

<https://standards.iteh.ai/catalog/standards/sist/a693-0a3aab4ad2bd/iso-12098-1994>

INTERNATIONAL

ISO



Reference number
ISO 12098:1994(E)

Foreword

ISO (the International Organization for Standardization) is a worldwide federation of national standards bodies (ISO member bodies). The work of preparing International Standards is normally carried out through ISO technical committees. Each member body interested in a subject for which a technical committee has been established has the right to be represented on that committee. International organizations, governmental and non-governmental, in liaison with ISO, also take part in the work. ISO collaborates closely with the International Electrotechnical Commission (IEC) on all matters of electrotechnical standardization.

Draft International Standards adopted by the technical committees are circulated to the member bodies for voting. Publication as an International Standard requires approval by at least 75 % of the member bodies casting a vote.

International Standard ISO 12098 was prepared by Technical Committee ISO/TC 22, *Road vehicles*, Subcommittee SC 3, *Electrical and electronic equipment*.

[ISO 12098:1994](https://standards.iteh.ai/catalog/standards/sist/30999b00-b357-4099-a075-0a5aab-4d2bd/iso-12098-1994)

Annex A forms an integral part of this International Standard.

© ISO 1994

All rights reserved. Unless otherwise specified, no part of this publication may be reproduced or utilized in any form or by any means, electronic or mechanical, including photocopying and microfilm, without permission in writing from the publisher.

International Organization for Standardization
Case Postale 56 • CH-1211 Genève 20 • Switzerland

Printed in Switzerland

Commercial vehicles with 24 V systems — 15-pole connectors between towing vehicles and trailers — Dimensions and contact allocation

1 Scope

This International Standard specifies dimensions and specific requirements for the 15-pole connector and its contact allocation to enable electrical connection between commercial towing vehicles and their trailers equipped with 24 V systems to be made and to ensure interchangeability.

It further specifies a park socket used to receive and store the plug when it is disconnected.

Annex A specifies characteristics of two adaptors to be used between a connector meeting the requirements of this International Standard and 7-pole connectors specified in ISO 1185 and ISO 3731.

2 Normative references

The following standards contain provisions which, through reference in this text, constitute provisions of this International Standard. At the time of publication, the editions indicated were valid. All standards are subject to revision, and parties to agreements based on this International Standard are encouraged to investigate the possibility of applying the most recent editions of the standards indicated below. Members of IEC and ISO maintain registers of currently valid International Standards.

ISO 1185:1975, *Road vehicles — Electrical connections between towing vehicles and towed vehicles with 24 V electrical equipment — Type 24 N (normal)*.

ISO 3731:1980, *Road vehicles — Electrical connections between towing vehicles and trailers with*

24 V electrical equipment — Type 24 S (supplementary).

ISO 4009:1989, *Towing vehicles — Mounting of electrical connections on rear cross-members*.

ISO 4091:1992, *Road vehicles — Connectors for electrical connections between towing vehicles and trailers — Test methods and performance requirements*.

ISO 7638:1985, *Road vehicles — Brake anti-lock device connector*.

3 Dimensions and design requirements

Dimensions and requirements of the socket, plug and park socket shall be in accordance with 3.1, 3.2 and 3.3 respectively.

The contacts shall be floating and shall align to the datum position when plug and socket are engaged.

Details not specified are at the manufacturer's discretion.

3.1 Socket

Dimensions and other requirements of the socket shall be as shown in figure 1.

The cover is shown in the open position: it shall close automatically when the plug is removed.

The contact designation numbers shall be permanently marked on the inside of the socket cover in numbers at least 2 mm high.

3.2 Plug

Dimensions and other requirements of the plug shall be as shown in figure 2.

The contact designation numbers shall be permanently marked on the terminal face, in numbers at least 2 mm high, although reduced space available may require a smaller size.

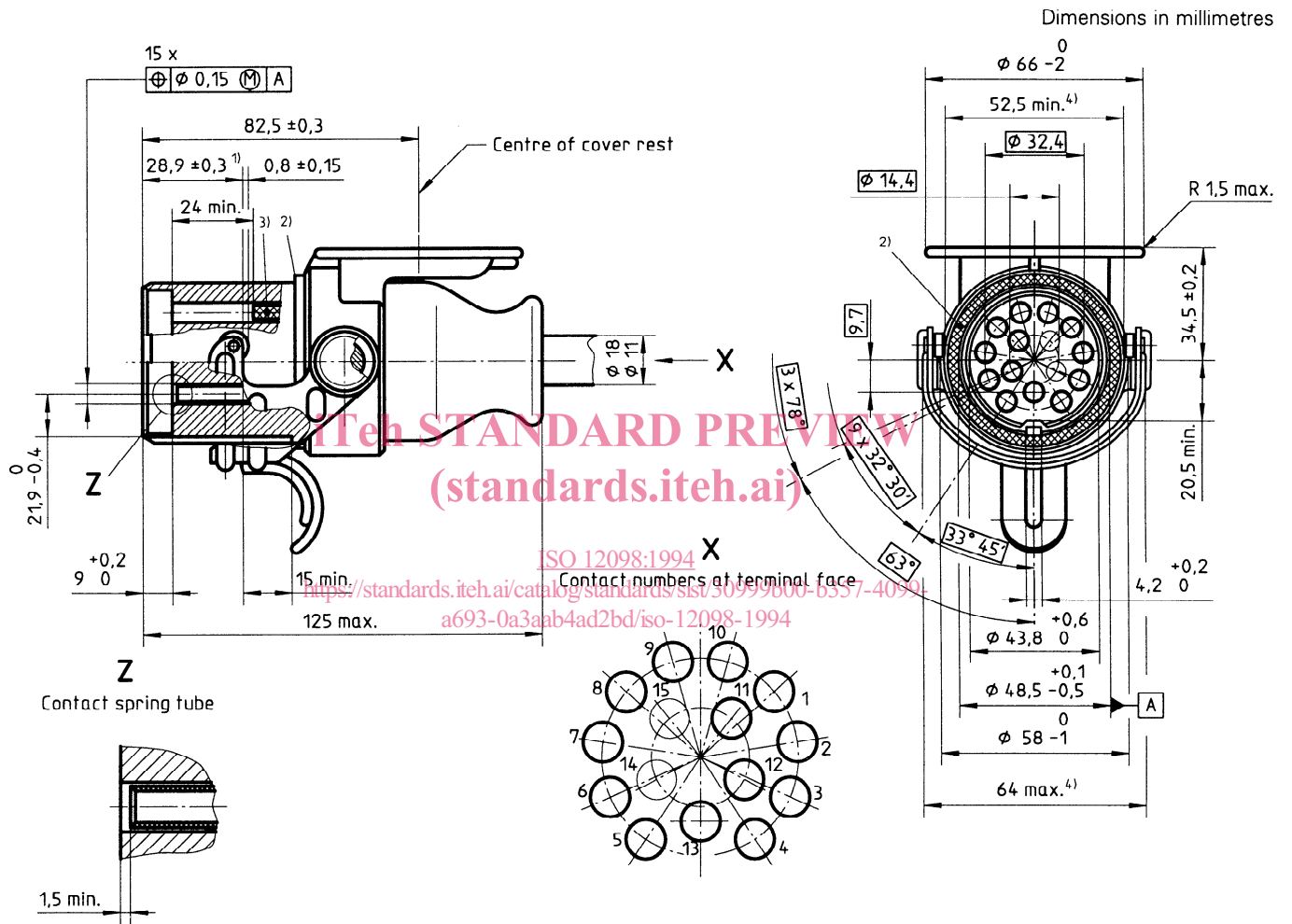

- 1) Locking lever in locked position.
- 2) Flat seal ring.
- 3) Insulating plug.
- 4) Applies to parts which might contact the socket closing device.

Figure 2 — Plug

Table 1

Contact No.	Function
1	Left-hand direction indicator light
2	Right-hand direction indicator light
3	Rear fog light
4	Common return
5	Left-hand rear position light(s), left-hand marker lights, and rear registration-plate illuminating device ¹⁾
6	Right-hand rear position light(s), right-hand marker lights, and rear registration-plate illuminating device ¹⁾
7	Stop lights
8	Reversing lights and reverse lock release for inertia brakes
9	Power supply (+ 24 V)
10	Worn brake lining sensor
11	Pressure sensor for spring brake
12	Axle lifting device
13	Common return for contacts 14 and 15
14	Reserved for data communication ²⁾
15	

1) The rear-registration-plate illuminating device shall be connected such that no lamp of such a device has a common connection to both contacts 5 and 6.

2) Contacts 14 and 15 which are not used at present shall be blanked to accept later fitment of pins and tubes for data transmission. These blanks shall permit 13-pole versions to be mated with 15-pole versions.

<https://standards.iteh.ai/catalog/standards/sist/30999b00-b357-4099-a693-0a3aab4ad2bd/iso-12098-1994>

5 Vehicle mounting

5.1 The sockets and plugs shall be mounted on the vehicles as shown in figure 4.

There shall always be a socket at the rear of the towing vehicle, fitted as specified in ISO 4009.

5.2 The minimum free space around the connector shall be as specified in figure 5.

6 Performance requirements

Connectors shall meet the performance requirements of ISO 4091.

It shall be impossible for pins and tubes of a connector meeting the requirements of this International Standard to make contact with pins and tubes of an ISO 7638 connector.

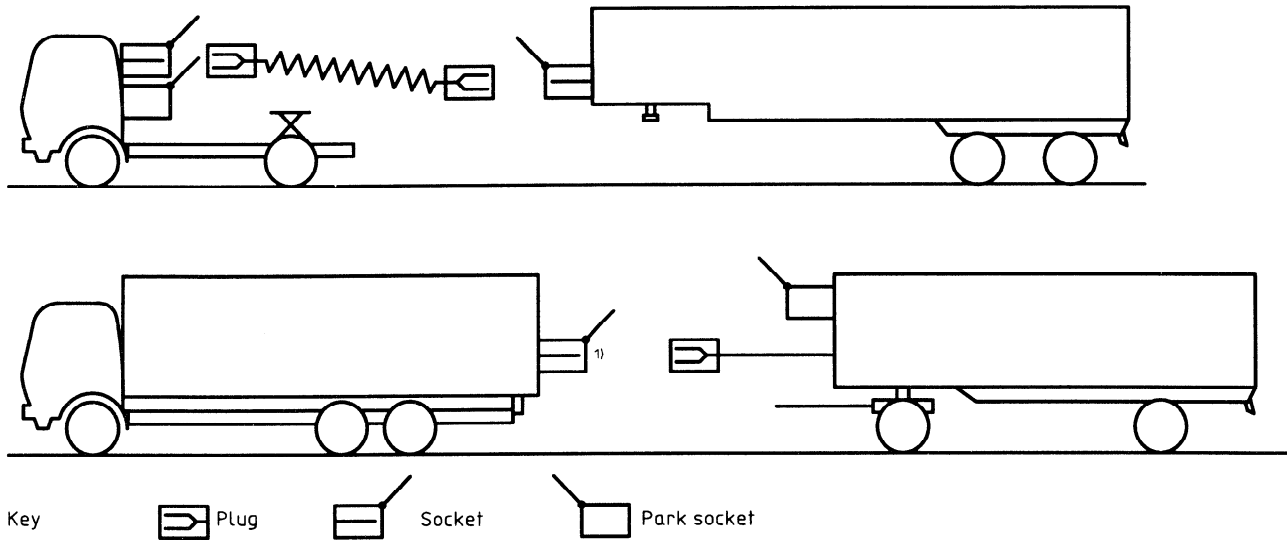

1) See ISO 4009.

Figure 4 — Positions of electrical connections on vehicles

iTeh STANDARD PREVIEW
(standards.iteh.ai)

Dimensions in millimetres

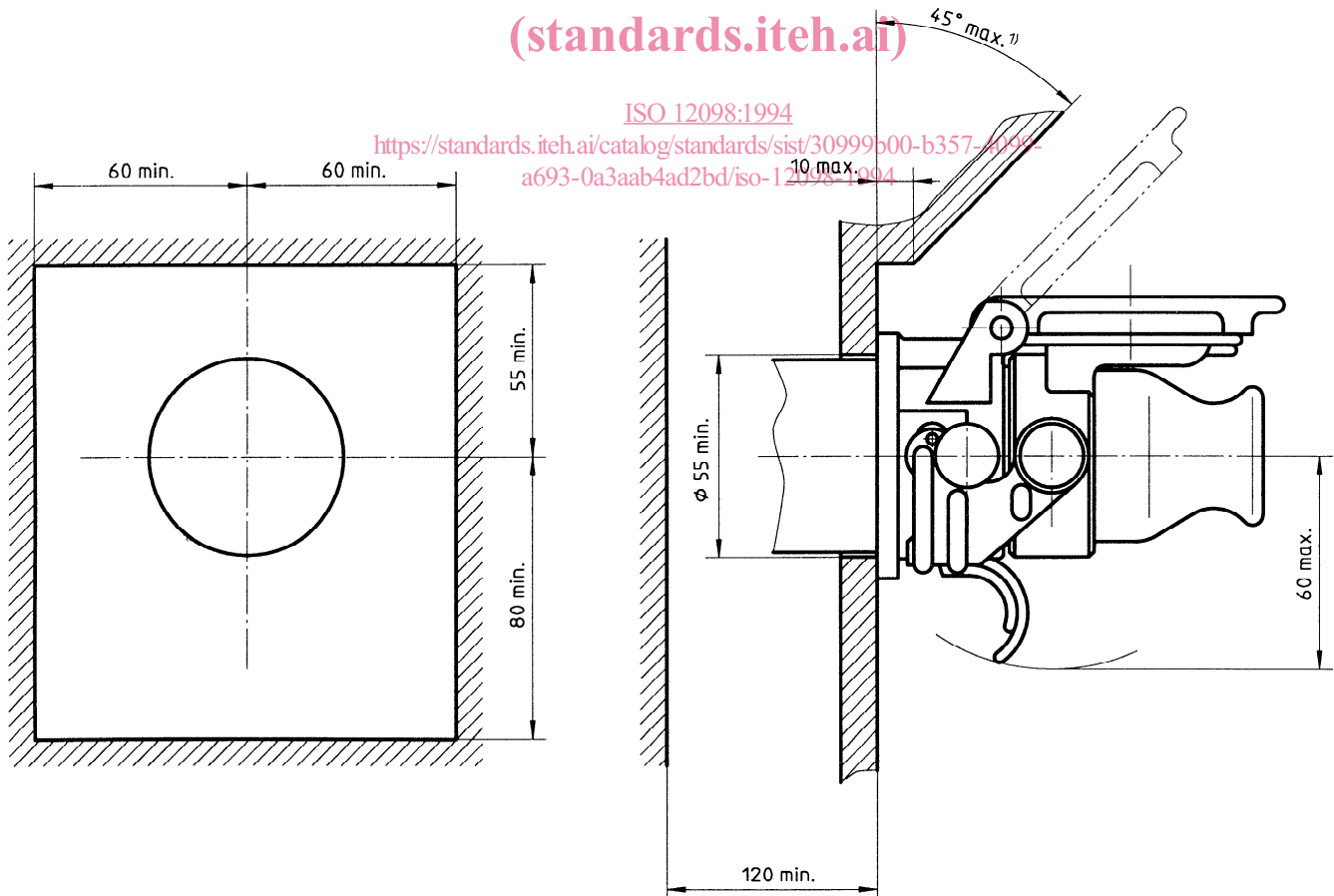

1) The angle of max. 45° shall extend across the full horizontal space.

Figure 5 — Free space

Annex A (normative)

Adaptation between 24 N and 24 S connectors and 15-pole connector specified in this International Standard

A.1 Introduction

Commercial vehicles with nominal 24 V systems have been equipped with 7-pole electrical connections according to ISO 1185 and ISO 3731. Commercial vehicles may now be equipped with 15-pole connections according to this International Standard. In order to ensure interchangeability between both types of vehicles, an adaptor designed in accordance with the following requirements may be used.

A.2 General limitation

Satisfactory adaptation between the 24 N, 24 S and the 15-pole connections is only feasible when the commercial vehicle and trailer involved are equipped

with connectors which fully conform to the specifications of ISO 1185, ISO 3731, ISO 4009 and this International Standard.

A.3 Mechanical requirements

To ensure mechanical compatibility of adaptors, the mating parts of the adaptor shall conform to the relevant dimensions specified in ISO 1185, ISO 3731 and this International Standard (see examples in figure A.1).

A.4 Electrical interchangeability

To ensure electrical interchangeability, the internal wiring of adaptors shall conform with figure A.2.

ISO 12098:1994

<https://standards.iteh.ai/catalog/standards/sist/30999b00-b357-4099-a693-0a3aab4ad2bd/iso-12098-1994>