



SLOVENSKI STANDARD SIST EN ISO 6218:2005

01-julij-2005

D`cj]UnUW`]bg_Yj cXYE`Fc bc`i dfUj `UbYj dYb`UbYdf]dfUj YnUg_`Ud`Ub`Y
dch]gb] `bUj Yn`f]c]h]gb]j `U]W`L! J UfbcghYnU hYj Y]b [`Uj bY`a YfY`f]GC
* &% .&\$ \$) Ł

Inland navigation vessels - Manually operated coupling devices for push tows - Safety requirements and main dimensions (ISO 6218:2005)

iTeh STANDARD PREVIEW

Fahrzeuge der Binnenschifffahrt - Handbetätigte Spannvorrichtungen für Seilverbindungen von Schubverbänden - Sicherheitsanforderungen und Hauptmaße (ISO 6218:2005)

[SIST EN ISO 6218:2005](https://standards.iteh.ai/catalog/standards/sist/f0ea8d38-84f9-498a-a464-839a9e4dc54e/sist-en-iso-6218-2005)

[https://standards.iteh.ai/catalog/standards/sist/f0ea8d38-84f9-498a-a464-](https://standards.iteh.ai/catalog/standards/sist/f0ea8d38-84f9-498a-a464-839a9e4dc54e/sist-en-iso-6218-2005)

[839a9e4dc54e/sist-en-iso-6218-2005](https://standards.iteh.ai/catalog/standards/sist/f0ea8d38-84f9-498a-a464-839a9e4dc54e/sist-en-iso-6218-2005)

Bateaux de navigation intérieure - Treuils d'accouplement manœuvrés a la main pour les convois poussés - Prescriptions de sécurité et dimensions principales (ISO 6218:2005)

Ta slovenski standard je istoveten z: EN ISO 6218:2005

ICS:

47.060 R: ^!•\ æš Á^ } æ] || çæ Inland navigation vessels

SIST EN ISO 6218:2005

en

iTeh STANDARD PREVIEW
(standards.iteh.ai)

[SIST EN ISO 6218:2005](#)

<https://standards.iteh.ai/catalog/standards/sist/f0ea8d38-84f9-498a-a464-839a9e4dc54e/sist-en-iso-6218-2005>

EUROPEAN STANDARD
NORME EUROPÉENNE
EUROPÄISCHE NORM

EN ISO 6218

April 2005

ICS 47.020.50; 47.060

English version

**Inland navigation vessels - Manually operated coupling devices
for push tows - Safety requirements and main dimensions (ISO
6218:2005)**

Bateaux de navigation intérieure - Treuils d'accouplement
manoeuvrés à la main pour les convois poussés -
Prescriptions de sécurité et dimensions principales (ISO
6218:2005)

Fahrzeuge der Binnenschifffahrt - Handbetätigte
Spannvorrichtungen für Seilverbindungen von
Schubverbänden - Sicherheitsanforderungen und
Hauptmaße (ISO 6218:2005)

This European Standard was approved by CEN on 14 January 2005.

CEN members are bound to comply with the CEN/CENELEC Internal Regulations which stipulate the conditions for giving this European Standard the status of a national standard without any alteration. Up-to-date lists and bibliographical references concerning such national standards may be obtained on application to the Central Secretariat or to any CEN member.

This European Standard exists in three official versions (English, French, German). A version in any other language made by translation under the responsibility of a CEN member into its own language and notified to the Central Secretariat has the same status as the official versions.

CEN members are the national standards bodies of Austria, Belgium, Cyprus, Czech Republic, Denmark, Estonia, Finland, France, Germany, Greece, Hungary, Iceland, Ireland, Italy, Latvia, Lithuania, Luxembourg, Malta, Netherlands, Norway, Poland, Portugal, Slovakia, Slovenia, Spain, Sweden, Switzerland and United Kingdom.



EUROPEAN COMMITTEE FOR STANDARDIZATION
COMITÉ EUROPÉEN DE NORMALISATION
EUROPÄISCHES KOMITEE FÜR NORMUNG

Management Centre: rue de Stassart, 36 B-1050 Brussels

Contents

Page

Foreword.....	3
1 Scope.....	4
2 Normative references.....	4
3 Terms and definitions.....	4
4 Safety requirements.....	4
4.1 General.....	4
4.2 Strength requirements.....	4
5 Models.....	5
5.1 Left-hand model (L).....	5
5.2 Right-hand model (R).....	5
5.3 With or without foundation.....	5
5.3.1 Type A.....	5
5.3.2 Type B.....	5
6 Design.....	5
6.1 Rope drum.....	5
6.1.1 Drum capacity.....	5
6.1.2 Drum diameter.....	5
6.1.3 Rope fastening.....	6
6.2 Handwheel.....	6
6.2.1 Clearance.....	6
6.2.2 Construction.....	6
6.2.3 Handhold.....	6
6.3 Arresting device.....	6
6.4 Pawls and ratchets.....	6
6.5 Protective device.....	6
6.6 Foot brakes.....	6
6.7 Gears.....	6
7 Dimensions.....	7
7.1 General.....	7
7.2 Main dimensions of the coupling device.....	7
7.3 Dimensions of the foundation.....	8
8 Material.....	9
8.1 Material of the flat bars of the foundation.....	9
8.2 Material of fastening bolts.....	9
9 Manufacturer's certification and operating instructions.....	9
9.1 Manufacturer's certification.....	9
9.2 Operating instructions.....	9
10 Designation.....	9
11 Marking.....	10
Annex A (normative) Type testing.....	11

Foreword

This document (EN ISO 6218:2005) has been prepared by Technical Committee CEN/TC 15 "Inland navigation vessels", the secretariat of which is held by DIN in cooperation with Technical Committee ISO/TC 8 "Ships and marine technology".

This European Standard EN ISO 6218 including the amendment shall be given the status of a national standard, either by publication of an identical text or by endorsement, at the latest by October 2005, and conflicting national standards shall be withdrawn at the latest by October 2005.

According to the CEN/CENELEC Internal Regulations, the national standards organizations of the following countries are bound to implement this European Standard: Austria, Belgium, Cyprus, Czech Republic, Denmark, Estonia, Finland, France, Germany, Greece, Hungary, Iceland, Ireland, Italy, Latvia, Lithuania, Luxembourg, Malta, Netherlands, Norway, Poland, Portugal, Slovakia, Slovenia, Spain, Sweden, Switzerland and the United Kingdom.

iTeh STANDARD PREVIEW (standards.iteh.ai)

[SIST EN ISO 6218:2005](https://standards.iteh.ai/catalog/standards/sist/f0ea8d38-84f9-498a-a464-839a9e4dc54e/sist-en-iso-6218-2005)

<https://standards.iteh.ai/catalog/standards/sist/f0ea8d38-84f9-498a-a464-839a9e4dc54e/sist-en-iso-6218-2005>

EN ISO 6218:2005 (E)

1 Scope

This standard specifies dimensions and safety requirements for manually operated coupling devices (securing devices) used for assembling inland navigation vessels as a push tow or vessels coupled alongside by means of wire rope connections.

It also gives rules for designation and testing.

2 Normative references

The following referenced documents are indispensable for the application of this document. For dated references, only the edition cited applies. For undated references, the latest edition of the referenced document (including any amendments) applies.

EN ISO 4014, *Hexagon head bolts – Product grades A and B (ISO 4014:1999)*.

ISO 1035-3, *Hot-rolled steel bars – Part 3: Dimensions of flat bars*.

ISO 2768-1, *General tolerances – Part 1: Tolerances for linear and angular dimensions without individual tolerance indications*.

3 Terms and definitions

For the purposes of this standard, the following terms and definitions apply.

3.1

manually operated coupling device

securing device in which a wire rope is coupled by turning a handwheel

3.2

coupling load

tensile load applied to the wire rope when a specific tangential load is applied to the handwheel

4 Safety requirements

4.1 General

All parts of the coupling devices shall be constructed so that their function is not impaired by vibration, tilt of the vessel or effects of the weather.

4.2 Strength requirements

All parts of the coupling devices shall be designed and secured so that they withstand the minimum breaking load of the wire rope according to Table 1.

5 Models

5.1 Left-hand model (L)

A left-hand model is a winch which has the handwheel and the drum on the left side of the gearing when looking in the direction in which the wire rope is paid out; see Figure 1.

5.2 Right-hand model (R)

A right-hand model is a winch which has the handwheel and the drum on the right side of the gearing when looking in the direction in which the wire rope is paid out; see Figure 2.

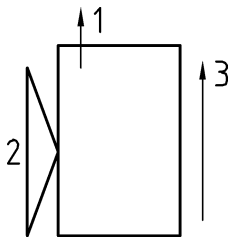

Key

- 1 Wire rope
- 2 Handwheel
- 3 Direction of view

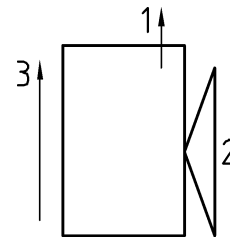

Key

- 1 Wire rope
- 2 Handwheel
- 3 Direction of view

Figure 1 — Left-hand model (L)

Figure 2 — Right-hand model (R)

SIST EN ISO 6218:2005
<https://standards.iteh.ai/catalog/standards/sist/f0ea8d38-84f9-498a-a464-829a9e4dc54e/sist-en-iso-6218-2005>

5.3 With or without foundation

5.3.1 Type A

With foundation (two flat steel bars and fastening bolts)

5.3.2 Type B

Without foundation or fastening bolts

6 Design

6.1 Rope drum

6.1.1 Drum capacity

Rope drums shall be dimensioned and constructed so that the ropes are prevented from running off at the side, e.g. by means of flanges that project above the top layer of the rope by at least 1,5 times the rope diameter.

6.1.2 Drum diameter

The drum diameter shall be not less than 12 times the maximum rope diameter.

EN ISO 6218:2005 (E)

6.1.3 Rope fastening

Wire ropes shall be fastened to the rope drum without kinking so that they do not slip off when being paid out.

6.2 Handwheel

6.2.1 Clearance

The clearance between the handwheel and the deck shall be at least 75 mm and the clearance between the winch plate and the outer surface of the handwheel shall not exceed 200 mm, see Figure 3.

6.2.2 Construction

The handwheel shall be constructed so that when the coupling device is released there is no risk of jamming with rapid rotation of the handwheel as a result of the wire rope being paid out.

The handwheel shall be constructed so that it is not possible to reach through with the arm or step in with the foot.

The clearance between the collars and the inner lining shall be at least 60 mm and shall not exceed 75 mm.

6.2.3 Handhold

Handwheels may be provided with a handhold. It shall be countersunk and shall not project beyond the outer plane of the handwheel. It shall be fitted with a rotatable grip.

6.3 Arresting device

Coupling devices shall be equipped with a reliable arresting device. It shall be designed, constructed and arranged so that it may be released without hazard by a person with simultaneous operation of the handwheel and foot brake. Arresting devices shall be designed so that they engage automatically when correctly operated.

6.4 Pawls and ratchets

Pawls and ratchets shall not be made of cast iron.

6.5 Protective device

Drawing-in points of gearwheels shall be provided with a protective device. It shall not be possible to remove this protective device without the use of a tool.

6.6 Foot brakes

Coupling devices shall be equipped with a foot brake that prevents the rope from being paid out under load when the arresting device is released. The foot brake shall operate smoothly and steplessly.

It shall be capable of holding a load of 1,5 times the coupling load as given in Table 1.

6.7 Gears

Coupling devices shall be equipped with gears with which it is possible to apply the coupling load to the rope as specified in Table 1. The tangential tensile load to be applied to the handwheel is 500 N.

7 Dimensions

7.1 General

For general tolerances: ISO 2768–c (ISO 2768-1) shall apply.

Coupling devices are not expected to conform to the design illustrated here; compliance is required only in the case of the dimensions specified.

7.2 Main dimensions of the coupling device

The characteristic values and the main dimensions are shown in Figure 3 and Table 1.

Dimensions in millimetres

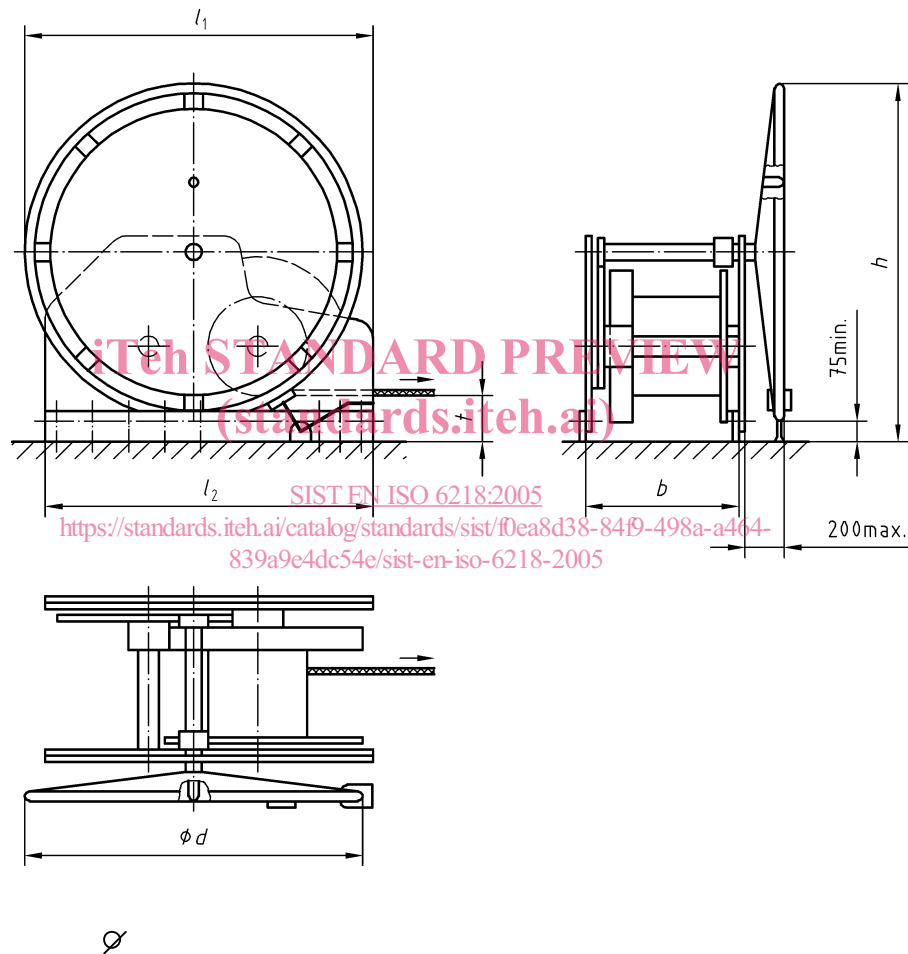

Key

- b width (distance from the outside of one winch plate/flat bar to the inside of the other winch plate/flat bar)
- ϕd diameter of the handwheel;
- h overall height;
- l_1 overall length;
- l_2 connecting length of the winch plate/flat bar to the deck;
- t distance from the wire rope to the deck.

Figure 3 — Coupling device (the drawing shows a right-hand model with partially braced handwheel without the protective device)