



Designation: D 402 – 02

American Association State
Highway and Transportation Officials Standard
AASHTO No.: T78



27/74 (88)

Standard Test Method for Distillation of Cut-Back Asphaltic (Bituminous) Products¹

This standard is issued under the fixed designation D 402; the number immediately following the designation indicates the year of original adoption or, in the case of revision, the year of last revision. A number in parentheses indicates the year of last reapproval. A superscript epsilon (ϵ) indicates an editorial change since the last revision or reapproval.

This standard has been approved for use by agencies of the Department of Defense. This method was adopted as a joint ASTM-IP standard in 1961.

1. Scope

1.1 This test method covers a distillation test for cut-back asphaltic (bituminous) products.

1.2 The values given in SI units are to be regarded as the standard. The inch-pound units given in parentheses are for information only.

1.3 *This standard does not purport to address all of the safety concerns, if any, associated with its use. It is the responsibility of the user of this standard to establish appropriate safety and health practices and determine the applicability of regulatory limitations prior to use.*

2. Referenced Documents

2.1 ASTM Standards:

D 86 Test Method for Distillation of Petroleum Products at Atmospheric Pressure²

D 370 Test Method for Dehydration of Oil-Type Preservatives³

E 1 Specification for ASTM Thermometers⁴

E 133 Specification for Distillation Equipment⁵

E 220 Test Method for Calibration of Thermocouples by Comparison Techniques⁴

2.2 IP Standards:

IP 123/ASTM D 86, Distillation of Petroleum Products Thermometers as specified in IP Standards

Crow Receiver as specified in British Standards 658:1989

C.O.3—Standard Methods for Testing Tar and its Products (Published by the U.K. Standardization of Tar Products Tests Committee)

3. Summary of Method

3.1 Two hundred millilitres of the sample are distilled in a 500-mL flask, at a controlled rate, to a temperature in the liquid of 360°C (680°F), and the volumes of distillate obtained at specified temperatures are measured. The residue from the distillation, and also the distillate, may be tested as required.

4. Significance and Use

4.1 This procedure measures the amount of the more volatile constituents in cut-back asphaltic products. The properties of the residue after distillation are not necessarily characteristic of the bitumen used in the original mixture, nor of the residue which may be left at any particular time after field application of the cut-back asphaltic product. The presence of silicone in the cut-back may affect the distillation residue by retarding the loss of volatile material after the residue has been poured into the residue container.

5. Apparatus

5.1 *Distillation Flask*, 500-mL side-arm, having the dimensions shown in Fig. 1.

5.2 *Condenser*, standard glass-jacketed, of nominal jacket length from 200 to 300 mm and overall tube length of 450 ± 10 mm (see Fig. 3).

5.3 *Adapter*, heavy-wall (1-mm) glass, with reinforced top, having an angle of approximately 105°. The inside diameter at the large end shall be approximately 18 mm, and at the small end, not less than 5 mm. The lower surface of the adapter shall be on a smooth descending curve from the larger end to the smaller. The inside line of the outlet end shall be vertical, and the outlet shall be cut or ground (not fire-polished) at an angle of 45 ± 5° to the inside line.

5.4 *Shield*, steel, lined with 3-mm fire proof insulation and fitted with transparent mica windows, of the form and dimensions shown in Fig. 2, used to protect the flask from air currents and to reduce radiation. The cover (top) shall be made in two parts of 6.4-mm fire proof insulation.

5.5 *Shield and Flask Support*—Two 15-cm² sheets of 16-mesh Chromel wire gauze on a tripod or ring.

¹ This test method is under the jurisdiction of ASTM Committee D04 on Road and Paving Materials and is the direct responsibility of Subcommittee D04.46 on Durability and Distillation Tests.

Current edition approved Dec. 10, 2002. Published February 2003. Originally approved in 1934. Last previous edition approved in 1997 as D 402 – 97.

In the IP, this method is under the jurisdiction of the Standardization Committee.

² *Annual Book of ASTM Standards*, Vol 05.01.

³ *Annual Book of ASTM Standards*, Vol 04.09.

⁴ *Annual Book of ASTM Standards*, Vol 14.03.

⁵ *Annual Book of ASTM Standards*, Vol 14.02.

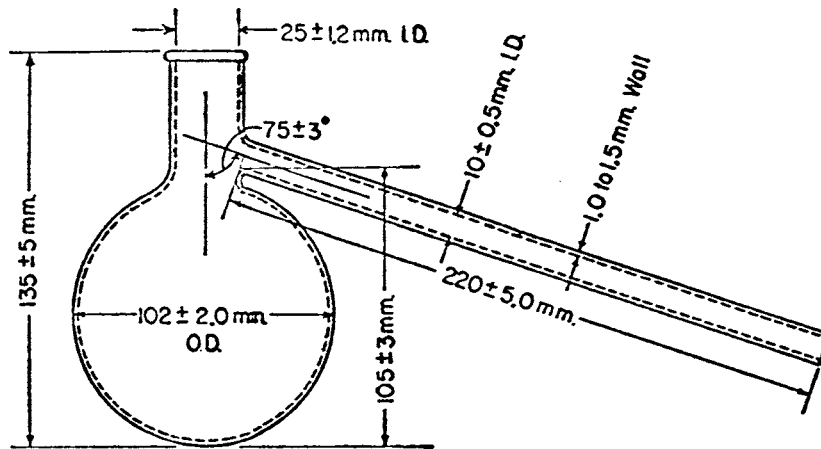
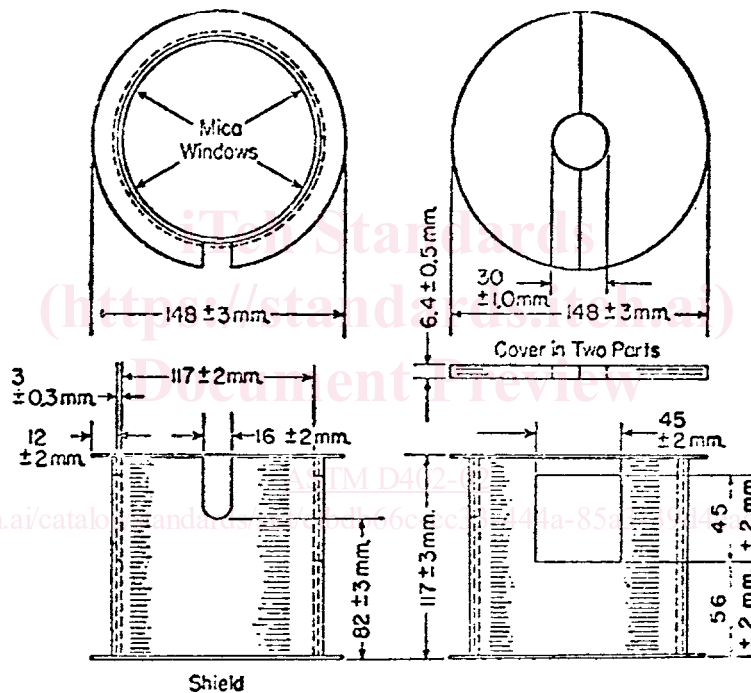

FIG. 1 Distillation Flask



Flanged Open-End Cylinder
Made of 22-Gage Galvanized
Iron with 3 mm Fire-Proof Lining
Riveted to Metal

Two Mica Windows are
Provided at Right Angles
to the End Slot.

FIG. 2 Shield

5.6 Heat Source—

5.6.1 Adjustable Tirrill-type gas burner or equivalent.

5.6.2 An electric heater equipped with a transformer capable of controlling from 0 to 750 W. The shield and support shall be a refractory with an opening of 79 mm, with the upper surface beveled to 86 mm to accommodate the specified 500-mL flask. When the flask is placed on the refractory, there should be a distance of approximately 3 mm between the bottom of the flask and the heating elements.

5.7 Receiver—A standard 100-mL graduated cylinder conforming to dimensions of Specification E 133, or a 100-mL Crow receiver as shown in Fig. 4 of this test method.

NOTE 1—Receivers of smaller capacity having 0.1-mL divisions may be used when low volumes of total distillate are expected and the added accuracy required.