**Rubber- or plastics-coated fabrics —
Determination of crush resistance**

*Supports textiles revêtus de caoutchouc ou de plastique — Détermination
de la résistance à l'écrasement*

iTeh STANDARD PREVIEW
(standards.iteh.ai)

[ISO 5473:1997](#)

<https://standards.iteh.ai/catalog/standards/sist/131de416-2dce-4548-a106-d19d6fa3ffe9/iso-5473-1997>



Foreword

ISO (the International Organization for Standardization) is a worldwide federation of national standards bodies (ISO member bodies). The work of preparing International Standards is normally carried out through ISO technical committees. Each member body interested in a subject for which a technical committee has been established has the right to be represented on that committee. International organizations, governmental and non-governmental, in liaison with ISO, also take part in the work. ISO collaborates closely with the International Electrotechnical Commission (IEC) on all matters of electrotechnical standardization.

Draft International Standards adopted by the technical committees are circulated to the member bodies for voting. Publication as an International Standard requires approval by at least 75 % of the member bodies casting a vote.

International Standard ISO 5473 was prepared by Technical Committee ISO/TC 45, *Rubber and rubber products*.

This second edition cancels and replaces the first edition (ISO 5473:1979), which has been technically revised.

iTeh STANDARD PREVIEW (standards.iteh.ai)

[ISO 5473:1997](https://standards.iteh.ai/catalog/standards/sist/131de416-2dce-4548-a106-d19d6fa3ffe9/iso-5473-1997)

<https://standards.iteh.ai/catalog/standards/sist/131de416-2dce-4548-a106-d19d6fa3ffe9/iso-5473-1997>

© ISO 1997

All rights reserved. Unless otherwise specified, no part of this publication may be reproduced or utilized in any form or by any means, electronic or mechanical, including photocopying and microfilm, without permission in writing from the publisher.

International Organization for Standardization
Case postale 56 • CH-1211 Genève 20 • Switzerland
Internet central@iso.ch
X.400 c=ch; a=400net; p=iso; o=isocs; s=central

Printed in Switzerland

Rubber- or plastics-coated fabrics — Determination of crush resistance

WARNING — Persons using this International Standard should be familiar with normal laboratory practice. This standard does not purport to address all of the safety problems, if any, associated with its use. It is the responsibility of the user to establish appropriate safety and health practices and to ensure compliance with any national regulatory conditions.

1 Scope

This International Standard specifies a method for determining the crush resistance of fabrics coated with rubber or plastics.

The method is applicable particularly to diaphragm material cut from coated fabrics.

2 Normative references

The following standards contain provisions which, through reference in this text, constitute provisions of this International Standard. At the time of publication, the editions indicated were valid. All standards are subject to revision, and parties to agreements based on this International Standard are encouraged to investigate the possibility of applying the most recent editions of the standards indicated below. Members of IEC and ISO maintain registers of currently valid International Standards.

ISO 2231:1989, *Rubber- or plastics-coated fabrics — Standard atmospheres for conditioning and testing*.
<http://standards.iso.org/iso/5473-1997>

ISO 2286-1:—¹⁾, *Rubber- or plastics-coated fabrics — Determination of roll characteristics — Part 1: Method for determination of the length, width and net mass of a roll*.

3 Principle

The coated fabric is subjected to a controlled load application over a known area until the fabric is crushed.

4 Apparatus

- 4.1 **Base plate**, having the dimensions shown in figure 1.
- 4.2 **Load button assembly**, having the dimensions shown in figure 2.
- 4.3 **Compression-testing machine**, having a speed of approximately 0,08 mm/s.

Any type of machine that will meet this requirement may also be used. For example, a platform scale equipped with a yoke over the platform and a hand-operated screw to apply the force will serve if it conforms to the requirements prescribed for accuracy and speed.

The load source shall have a total capacity of at least 5 400 N.

1) To be published. (Revision, in parts, of ISO 2286:1986)

Dimensions in millimetres

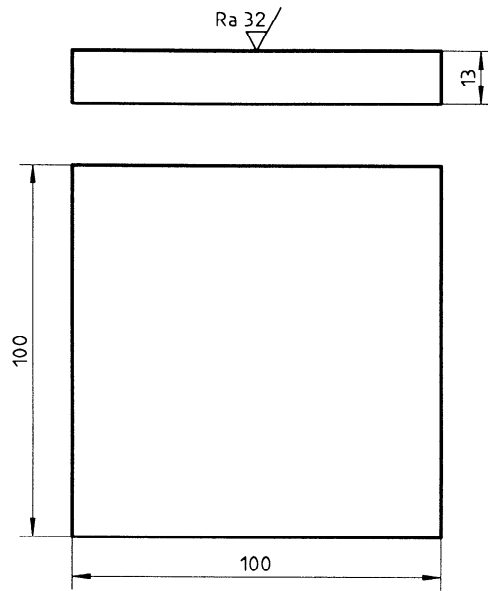
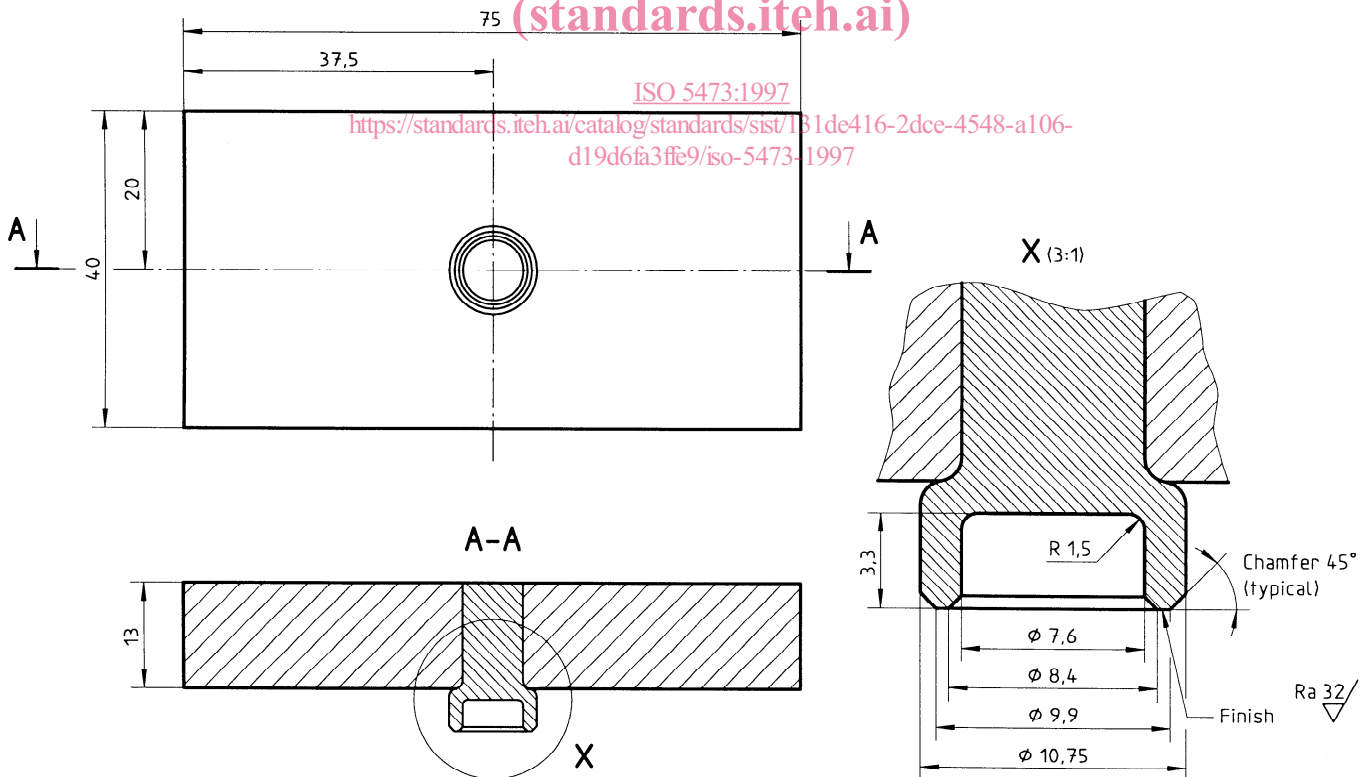

Figure 1 — Base plate

iTeh STANDARD PREVIEW
(standards.iteh.ai)

Dimensions in millimetres



NOTES

- 1 All sharp edges to be removed.
- 2 Button to be press-fitted in plate.

Figure 2 — Load button assembly

4.4 Force-recording mechanism, comprising a calibrated dial with a maximum pointer, or a strip-chart to indicate the force required to crush the fabric.

Unless otherwise specified for force determination, the machine shall be so adjusted that the maximum force required to crush the test piece may be readily detected by the maximum pointer or read from the strip-chart.

The error of the machine shall not exceed 2 % up to and including 200 N force and 1 % over 200 N force.

5 Test pieces

Cut the test pieces from the usable width of the roll as defined in ISO 2286-1.

The test pieces shall be at least 50 mm wide and 200 mm long. At least three test values shall be obtained from each sample.

6 Time-interval between manufacturing and testing

6.1 For all purposes, the minimum time between manufacturing and testing shall be 16 h.

6.2 When the test is for comparison of materials, it is strongly recommended that these periods be as close to each other as possible.

6.3 For product tests, the time between manufacturing and testing should, whenever possible, not exceed 3 months. In other cases, tests shall be made within 2 months of the date of receipt by the customer.

(standards.iteh.ai)

7 Conditioning and test atmosphere

ISO 5473:1997

The test pieces shall be conditioned and tested in one of the atmospheres A, B and C defined in ISO 2231.

8 Procedure

8.1 Place the base plate (4.1) on the platform of the testing machine (4.3) and place the test piece on the base plate.

If the material to be tested has an unbalanced coating, the side having the thicker coating shall be facing upward.

8.2 Place the load button of the machine on to the test piece so that the recess of the button, as shown in figure 2, is in contact with the test piece and its axis is perpendicular to the plane of the test piece. The circumference of the load button shall be at least 12 mm from any edge of the test piece. Apply the force to the button at the rate of approximately 0,08 mm/s until the shear yield point or maximum deflection of the dial pointer is reached, whichever is the lesser. Record the force required to crush the test piece. Repeat the procedure at least twice more on a new area of the test piece at least 12 mm away from other test sites and from any edge.

8.3 Fabric crushing can readily be detected by stretching the test piece. The fabric will have noticeably less resistance to stretching in the damaged areas when compared with the undamaged areas.

9 Test report

The test report shall include the following particulars:

- a) a reference to this International Standard;
- b) the reference and date of manufacture, if known, of each sample tested;

- c) the atmosphere used for conditioning and testing;
- d) the number of test pieces tested;
- e) the force required to crush the coating or the fabric, whichever occurs first, in each test piece.

iTeh STANDARD PREVIEW
(standards.iteh.ai)

[ISO 5473:1997](https://standards.iteh.ai/catalog/standards/sist/131de416-2dce-4548-a106-d19d6fa3ffe9/iso-5473-1997)

<https://standards.iteh.ai/catalog/standards/sist/131de416-2dce-4548-a106-d19d6fa3ffe9/iso-5473-1997>

iTeh STANDARD PREVIEW
This page intentionally left blank
(standards.iteh.ai)

ISO 5473:1997

<https://standards.iteh.ai/catalog/standards/sist/131de416-2dce-4548-a106-d19d6fa3ffe9/iso-5473-1997>

iTeh STANDARD PREVIEW
(standards.iteh.ai)

[ISO 5473:1997](#)

<https://standards.iteh.ai/catalog/standards/sist/131de416-2dce-4548-a106-d19d6fa3ffe9/iso-5473-1997>

ICS 59.080.40

Descriptors: fabrics, woven fabrics, coated fabrics, fabrics coated with rubber, fabrics coated with plastics, tests, crushing tests, compression tests, determination, crushing strength.

Price based on 4 pages
