

INTERNATIONAL STANDARD

NORME INTERNATIONALE



**Energy management system application program interface (EMS-API) –
Part 452: CIM model exchange specification**

**Interface de programmation d'application pour système de gestion d'énergie
(EMS-API) –**

Partie 452: Spécification d'échange de modèle CIM



THIS PUBLICATION IS COPYRIGHT PROTECTED

Copyright © 2015 IEC, Geneva, Switzerland

All rights reserved. Unless otherwise specified, no part of this publication may be reproduced or utilized in any form or by any means, electronic or mechanical, including photocopying and microfilm, without permission in writing from either IEC or IEC's member National Committee in the country of the requester. If you have any questions about IEC copyright or have an enquiry about obtaining additional rights to this publication, please contact the address below or your local IEC member National Committee for further information.

Droits de reproduction réservés. Sauf indication contraire, aucune partie de cette publication ne peut être reproduite ni utilisée sous quelque forme que ce soit et par aucun procédé, électronique ou mécanique, y compris la photocopie et les microfilms, sans l'accord écrit de l'IEC ou du Comité national de l'IEC du pays du demandeur. Si vous avez des questions sur le copyright de l'IEC ou si vous désirez obtenir des droits supplémentaires sur cette publication, utilisez les coordonnées ci-après ou contactez le Comité national de l'IEC de votre pays de résidence.

IEC Central Office
3, rue de Varembe
CH-1211 Geneva 20
Switzerland

Tel.: +41 22 919 02 11
Fax: +41 22 919 03 00
info@iec.ch
www.iec.ch

About the IEC

The International Electrotechnical Commission (IEC) is the leading global organization that prepares and publishes International Standards for all electrical, electronic and related technologies.

About IEC publications

The technical content of IEC publications is kept under constant review by the IEC. Please make sure that you have the latest edition, a corrigenda or an amendment might have been published.

IEC Catalogue - webstore.iec.ch/catalogue

The stand-alone application for consulting the entire bibliographical information on IEC International Standards, Technical Specifications, Technical Reports and other documents. Available for PC, Mac OS, Android Tablets and iPad.

IEC publications search - www.iec.ch/searchpub

The advanced search enables to find IEC publications by a variety of criteria (reference number, text, technical committee,...). It also gives information on projects, replaced and withdrawn publications.

IEC Just Published - webstore.iec.ch/justpublished

Stay up to date on all new IEC publications. Just Published details all new publications released. Available online and also once a month by email.

Electropedia - www.electropedia.org

The world's leading online dictionary of electronic and electrical terms containing 20 000 terms and definitions in English and French, with equivalent terms in 16 additional languages. Also known as the International Electrotechnical Vocabulary (IEV) online.

IEC Glossary - std.iec.ch/glossary

65 000 electrotechnical terminology entries in English and French extracted from the Terms and Definitions clause of IEC publications issued since 2002. Some entries have been collected from earlier publications of IEC TC 37, 77, 86 and CISPR.

IEC Customer Service Centre - webstore.iec.ch/csc

If you wish to give us your feedback on this publication or need further assistance, please contact the Customer Service Centre: csc@iec.ch.

A propos de l'IEC

La Commission Electrotechnique Internationale (IEC) est la première organisation mondiale qui élabore et publie des Normes internationales pour tout ce qui a trait à l'électricité, à l'électronique et aux technologies apparentées.

A propos des publications IEC

Le contenu technique des publications IEC est constamment revu. Veuillez vous assurer que vous possédez l'édition la plus récente, un corrigendum ou amendement peut avoir été publié.

Catalogue IEC - webstore.iec.ch/catalogue

Application autonome pour consulter tous les renseignements bibliographiques sur les Normes internationales, Spécifications techniques, Rapports techniques et autres documents de l'IEC. Disponible pour PC, Mac OS, tablettes Android et iPad.

Recherche de publications IEC - www.iec.ch/searchpub

La recherche avancée permet de trouver des publications IEC en utilisant différents critères (numéro de référence, texte, comité d'études,...). Elle donne aussi des informations sur les projets et les publications remplacées ou retirées.

IEC Just Published - webstore.iec.ch/justpublished

Restez informé sur les nouvelles publications IEC. Just Published détaille les nouvelles publications parues. Disponible en ligne et aussi une fois par mois par email.

Electropedia - www.electropedia.org

Le premier dictionnaire en ligne de termes électroniques et électriques. Il contient 20 000 termes et définitions en anglais et en français, ainsi que les termes équivalents dans 16 langues additionnelles. Egalement appelé Vocabulaire Electrotechnique International (IEV) en ligne.

Glossaire IEC - std.iec.ch/glossary

65 000 entrées terminologiques électrotechniques, en anglais et en français, extraites des articles Termes et Définitions des publications IEC parues depuis 2002. Plus certaines entrées antérieures extraites des publications des CE 37, 77, 86 et CISPR de l'IEC.

Service Clients - webstore.iec.ch/csc

Si vous désirez nous donner des commentaires sur cette publication ou si vous avez des questions contactez-nous: csc@iec.ch.

INTERNATIONAL STANDARD

NORME INTERNATIONALE



**Energy management system application program interface (EMS-API) –
Part 452: CIM model exchange specification**

**Interface de programmation d'application pour système de gestion d'énergie
(EMS-API) –**

Partie 452: Spécification d'échange de modèle CIM

INTERNATIONAL
ELECTROTECHNICAL
COMMISSION

COMMISSION
ELECTROTECHNIQUE
INTERNATIONALE

ICS 33.200

ISBN 978-2-8322-4511-8

**Warning! Make sure that you obtained this publication from an authorized distributor.
Attention! Veuillez vous assurer que vous avez obtenu cette publication via un distributeur agréé.**

CONTENTS

FOREWORD.....	6
INTRODUCTION.....	9
1 Scope.....	10
2 Normative references	11
3 Overview of data requirements	11
3.1 Overview.....	11
3.2 General requirements	11
3.3 Transformer modeling.....	12
3.4 Modeling authorities.....	13
3.5 Use of measurement classes	14
3.5.1 General	14
3.5.2 ICCP data exchange.....	15
3.6 Voltage or active power regulation	15
3.7 Use of curves.....	15
3.7.1 General	15
3.7.2 Generating unit reactive power limits	15
3.8 Definition of schedules.....	16
4 CIM Equipment Profile.....	16
4.1 CIM Equipment Profile General.....	16
4.2 Concrete Classes.....	16
4.2.1 Accumulator	16
4.2.2 AccumulatorValue.....	17
4.2.3 ACLineSegment.....	17
4.2.4 ActivePowerLimit.....	19
4.2.5 Analog	19
4.2.6 AnalogValue	20
4.2.7 ApparentPowerLimit	20
4.2.8 BaseVoltage	20
4.2.9 Bay.....	21
4.2.10 Breaker.....	21
4.2.11 BusbarSection	21
4.2.12 ConformLoad.....	22
4.2.13 ConformLoadGroup	22
4.2.14 ConformLoadSchedule	23
4.2.15 ConnectivityNode	23
4.2.16 ControlArea	24
4.2.17 ControlAreaGeneratingUnit.....	24
4.2.18 CurrentLimit.....	25
4.2.19 CurveData	25
4.2.20 DayType	26
4.2.21 Disconnecter	26
4.2.22 Discrete	26
4.2.23 DiscreteValue	27
4.2.24 EnergyConsumer.....	27
4.2.25 EquivalentBranch	28
4.2.26 EquivalentInjection	29

4.2.27	EquivalentNetwork.....	30
4.2.28	EquivalentShunt	30
4.2.29	FossilFuel.....	30
4.2.30	GeneratingUnit	31
4.2.31	GeographicalRegion	33
4.2.32	GrossToNetActivePowerCurve.....	33
4.2.33	HydroGeneratingUnit	34
4.2.34	HydroPump.....	34
4.2.35	IEC61970CIMVersion	35
4.2.36	Line	35
4.2.37	LoadArea.....	35
4.2.38	LoadBreakSwitch.....	36
4.2.39	LoadResponseCharacteristic	36
4.2.40	MeasurementValueSource	38
4.2.41	MutualCoupling.....	38
4.2.42	Name.....	39
4.2.43	NameType	40
4.2.44	NonConformLoad.....	40
4.2.45	NonConformLoadGroup	41
4.2.46	NonConformLoadSchedule	41
4.2.47	NuclearGeneratingUnit	42
4.2.48	OperationalLimitSet	42
4.2.49	OperationalLimitType.....	43
4.2.50	PhaseTapChangerAsymetrical.....	43
4.2.51	PhaseTapChangerLinear	44
4.2.52	PhaseTapChangerSymetrical.....	45
4.2.53	PhaseTapChangerTabular	46
4.2.54	PhaseTapChangerTabularPoint	46
4.2.55	PowerTransformer	47
4.2.56	PowerTransformerEnd	48
4.2.57	RatioTapChanger	50
4.2.58	RatioTapChangerTabular.....	50
4.2.59	RatioTapChangerTabularPoint.....	51
4.2.60	ReactiveCapabilityCurve.....	52
4.2.61	RegularTimePoint	53
4.2.62	RegulatingControl.....	53
4.2.63	RegulationSchedule.....	55
4.2.64	Season	55
4.2.65	SeriesCompensator	56
4.2.66	ShuntCompensator	56
4.2.67	StaticVarCompensator	57
4.2.68	StationSupply	58
4.2.69	SubGeographicalRegion	59
4.2.70	SubLoadArea.....	59
4.2.71	Substation	59
4.2.72	Switch	60
4.2.73	SwitchSchedule	60
4.2.74	SynchronousMachine.....	61
4.2.75	TapChangerControl	63

4.2.76	TapSchedule	63
4.2.77	Terminal	64
4.2.78	ThermalGeneratingUnit.....	64
4.2.79	TieFlow.....	65
4.2.80	VoltageLevel.....	65
4.2.81	VoltageLimit	66
4.2.82	WindGeneratingUnit	66
4.3	Abstract Classes.....	67
4.3.1	BasicIntervalSchedule	67
4.3.2	ConductingEquipment.....	67
4.3.3	Conductor.....	68
4.3.4	ConnectivityNodeContainer	68
4.3.5	Curve	68
4.3.6	EnergyArea	69
4.3.7	Equipment	69
4.3.8	EquipmentContainer	69
4.3.9	EquivalentEquipment.....	70
4.3.10	IdentifiedObject	70
4.3.11	LoadGroup	71
4.3.12	Measurement.....	71
4.3.13	MeasurementValue.....	72
4.3.14	OperationalLimit	72
4.3.15	PhaseTapChanger.....	73
4.3.16	PhaseTapChangerNonLinear.....	73
4.3.17	PowerSystemResource.....	74
4.3.18	RegularIntervalSchedule.....	74
4.3.19	RegulatingCondEq.....	75
4.3.20	RotatingMachine.....	75
4.3.21	SeasonDayTypeSchedule	76
4.3.22	TapChanger.....	76
4.3.23	TransformerEnd.....	77
4.4	Enumerations.....	78
4.4.1	ControlAreaTypeKind.....	78
4.4.2	CurveStyle.....	78
4.4.3	FuelType	79
4.4.4	GeneratorControlSource	79
4.4.5	OperationalLimitDirectionKind.....	79
4.4.6	RegulatingControlModeKind	79
4.4.7	SeasonName	80
4.4.8	SVCControlMode	80
4.4.9	SynchronousMachineOperatingMode.....	80
4.4.10	SynchronousMachineType	80
4.4.11	TapChangerKind.....	81
4.4.12	TransformerControlMode	81
4.4.13	UnitSymbol	81
4.4.14	WindingConnection.....	82
4.5	Datatypes	82
4.5.1	ActivePower	82
4.5.2	AngleDegrees.....	82

4.5.3	ApparentPower	82
4.5.4	Conductance	82
4.5.5	CurrentFlow	83
4.5.6	Length	83
4.5.7	Money	83
4.5.8	PerCent	83
4.5.9	Reactance	83
4.5.10	ReactivePower	84
4.5.11	Resistance	84
4.5.12	Seconds	84
4.5.13	Susceptance	84
4.5.14	Voltage	84
4.5.15	VoltagePerReactivePower	84
5	Amplifications and conventions	85
5.1	Overview	85
5.2	XML file validity	85
5.3	Normative string tables	85
5.4	Roles and multiplicity	86
Annex A (informative) Model exchange use cases		87
Annex B (informative) Modeling authorities		91
Annex C (informative) Common power system model (CPSM) minimum data requirements		93
Bibliography		99
<p style="text-align: center;">IEC 61970-452:2015 https://standards-iteh.org/catalog/standards/sib/6e8163e6-a80e-4029-961b-69016366bd81/iec-61970-452-2015</p>		
Figure 1 – Two winding transformer impedance		12
Figure 2 – Three winding transformer impedance		13
Figure A.1 – Security coordinators		87
Figure A.2 – CIM model exchange		88
Figure A.3 – Revised CIM model exchange		89
Figure A.4 – Hierarchical modeling		90
Table 1 – Valid measurementTypes		14
Table 2 – Profiles defined in this document		16
Table 3 – Valid attribute values		85

INTERNATIONAL ELECTROTECHNICAL COMMISSION

**ENERGY MANAGEMENT SYSTEM APPLICATION
PROGRAM INTERFACE (EMS-API) –****Part 452: CIM model exchange specification**

FOREWORD

- 1) The International Electrotechnical Commission (IEC) is a worldwide organization for standardization comprising all national electrotechnical committees (IEC National Committees). The object of IEC is to promote international co-operation on all questions concerning standardization in the electrical and electronic fields. To this end and in addition to other activities, IEC publishes International Standards, Technical Specifications, Technical Reports, Publicly Available Specifications (PAS) and Guides (hereafter referred to as "IEC Publication(s)"). Their preparation is entrusted to technical committees; any IEC National Committee interested in the subject dealt with may participate in this preparatory work. International, governmental and non-governmental organizations liaising with the IEC also participate in this preparation. IEC collaborates closely with the International Organization for Standardization (ISO) in accordance with conditions determined by agreement between the two organizations.
- 2) The formal decisions or agreements of IEC on technical matters express, as nearly as possible, an international consensus of opinion on the relevant subjects since each technical committee has representation from all interested IEC National Committees.
- 3) IEC Publications have the form of recommendations for international use and are accepted by IEC National Committees in that sense. While all reasonable efforts are made to ensure that the technical content of IEC Publications is accurate, IEC cannot be held responsible for the way in which they are used or for any misinterpretation by any end user.
- 4) In order to promote international uniformity, IEC National Committees undertake to apply IEC Publications transparently to the maximum extent possible in their national and regional publications. Any divergence between any IEC Publication and the corresponding national or regional publication shall be clearly indicated in the latter.
- 5) IEC itself does not provide any attestation of conformity. Independent certification bodies provide conformity assessment services and, in some areas, access to IEC marks of conformity. IEC is not responsible for any services carried out by independent certification bodies.
- 6) All users should ensure that they have the latest edition of this publication.
- 7) No liability shall attach to IEC or its directors, employees, servants or agents including individual experts and members of its technical committees and IEC National Committees for any personal injury, property damage or other damage of any nature whatsoever, whether direct or indirect, or for costs (including legal fees) and expenses arising out of the publication, use of, or reliance upon, this IEC Publication or any other IEC Publications.
- 8) Attention is drawn to the Normative references cited in this publication. Use of the referenced publications is indispensable for the correct application of this publication.
- 9) Attention is drawn to the possibility that some of the elements of this IEC Publication may be the subject of patent rights. IEC shall not be held responsible for identifying any or all such patent rights.

The present part of International Standard IEC 61970 has been prepared by IEC technical committee 57: Power systems management and associated information exchange.

This second edition cancels and replaces the first edition published in 2013. This edition constitutes a technical revision.

This edition includes the following significant technical changes with respect to the previous edition:

- a) subclause 3.3, Transformer modeling – Updated description of transformer modelling to reflect changes in the modelling of transformers to work for both transmission and distribution systems;
- b) subclause 3.5.1, Use of measurement classes – General – Updated to reflect changes to the measurement model;

- c) subclause 3.5.2, ICCP data exchange – Updated to reflect changes to the use of identification in the model (IdentifiedObject, Name, and NameType);
- d) the following detailed changes were made to Clause 4, CIM Equipment Profile:
- Added Measurement.unitMultiplier and Measurement.unitSymbol to replace association to class Unit.
 - Added PowerTransformerEnd to replace TransformerWinding.
 - Made PhaseTapChanger not concrete (abstract) and added PhaseTapChangerNonLinear (also not concrete), PhaseTapChangerSymmetrical, PhaseTapChangerAsymmetrical, and PhaseTapChangerLinear.
 - Added PhaseTapChanger.TransformerEnd to replace PhaseTapChanger.TransformerWinding.
 - Added RatioTapChanger.TransformerEnd to replace RatioTapChanger.TransformerWinding.
 - Added TapChangerControl class to replace direct link TapChanger.RegulatingControl.
 - Added RatioTapChanger.stepVoltageIncrement to replace TapChanger.stepVoltageIncrement.
 - Added PhaseTapChangerTabular, PhaseTapChangerTabularPoint, RatioTapChangerTabular, and RatioTapChangerTabularPoint to replace ImpedanceVariationCurve, PhaseVariationCurve, and RatioVariationCurve.
 - Added Switch.ratedCurrent as optional attribute.
 - Changed all attributes of LoadResponseCharacteristic to optional except for exponentModel.
 - Changed CurveData.y2Value to optional.
 - Added PowerTransformer.vectorGroup as optional attribute.
 - Added note to OperationalLimitSet stating that “Either an association to Equipment or an association to Terminal must be supplied, but not both.”
 - Added SeriesCompensator.r0 and x0 as optional attributes.
 - Added attributes for PhaseTapChangerTabularPoint and RatioTapChangerTabularPoint.
 - Added RotatingMachine to the profile so that ratedS can be inherited by SynchronousMachine as an optional attribute.
 - Changed association between RegulatingCondEq and RegulatingControl to be optional.
 - Made OperationalLimitType attributes direction and acceptableDuration optional.
 - Added classes Name and NameType to profile.
 - Removed PowerTransformer.vectorGroup from the profile.
 - Added PowerTransformerEnd.phaseAngleClock as an optional attribute.
 - Made attributes RegulatingControl.targetRange and targetValue optional and added a note stating that they are not required if a RegulationSchedule is provided.
 - Added TransformerEnd.endNumber to the profile for use with PowerTransformerEnd.phaseAngleClock.
 - Added association OperationalLimit.OperationalLimitSet.
 - Added association Name.IdentifiedObject.
 - Updated PowerTransformer profile description to also refer to Terminals.
 - Changed reference to association RegulatingControl.RegulationSchedule to use RegulationSchedule.RegulatingControl instead.

- Changed TapChanger attributes highStep, lowStep, neutralStep and normalStep to optional, because they are not required if the ltcFlag is false.
- Changed BasicIntervalSchedule.value2Unit and RegularTimePoint.value2 to optional, because they are not required for RegulationSchedule, TapSchedule or SwitchSchedule.
- Changed Analog.positiveFlowIn to be optional, because not all analogs have a flow direction (voltage, for instance).
- Added PowerTransformerEnd.g as optional attribute.
- Added SynchronousMachine.referencePriority as optional attribute.
- Added profile description for AccumulatorValue, AnalogValue, and DiscreteValue explaining that the classes are only used to define measurements available via ICCP, not to supply values for those measurements.
- Added attribute Switch.retained as required.
- Added association TransformerEnd.BaseVoltage as optional.
- Made association ControlArea.energyArea optional.

This bilingual version (2018-07) corresponds to the monolingual English version, published in 2015-04.

The text of this standard is based on the following documents:

CDV	Report on voting
57/1451/CDV	57/1503/RVC

Full information on the voting for the approval of this standard can be found in the report on voting indicated in the above table. [IEC 61970-452:2015](https://standards.iteh.ai/catalog/standards/sist/3c8f63c6-a80e-4029-9bfb-69016366bd81/iec-61970-452-2015)

<https://standards.iteh.ai/catalog/standards/sist/3c8f63c6-a80e-4029-9bfb-69016366bd81/iec-61970-452-2015>
The French version of this standard has not been voted upon.

This publication has been drafted in accordance with the ISO/IEC Directives, Part 2.

A list of all parts in the IEC 61970 series, published under the general title *Energy management system application program interface (EMS-API)*, can be found on the IEC website.

The committee has decided that the contents of this publication will remain unchanged until the stability date indicated on the IEC web site under "http://webstore.iec.ch" in the data related to the specific publication. At this date, the publication will be

- reconfirmed,
- withdrawn,
- replaced by a revised edition, or
- amended.

IMPORTANT – The 'colour inside' logo on the cover page of this publication indicates that it contains colours which are considered to be useful for the correct understanding of its contents. Users should therefore print this document using a colour printer.

INTRODUCTION

This standard is one of the IEC 61970 series that define an application program interface (API) for an energy management system (EMS).

The IEC 61970-3x series of documents specify a Common Information Model (CIM). The CIM is an abstract model that represents all of the major objects in an electric utility enterprise typically needed to model the operational aspects of a utility. It provides the semantics for the IEC 61970 APIs specified in the IEC 61970-4x series of Component Interface Standards (CIS). The IEC 61970-3x series includes IEC 61970-301, *Common Information Model (CIM) base* and draft standard IEC 61970-302, *Common Information Model (CIM) Financial, Energy Scheduling and Reservations*.

This standard is one of the IEC 61970-4x series of Component Interface Standards that specify the functional requirements for interfaces that a component (or application) shall implement to exchange information with other components (or applications) and/or to access publicly available data in a standard way. The component interfaces describe the specific message contents and services that can be used by applications for this purpose. The implementation of these messages in a particular technology is described in IEC 61970-5.

This part of IEC 61970 specifies the specific profiles (or subsets) of the CIM for exchange of static power system data between utilities, security coordinators and other entities participating in an interconnected power system, such that all parties have access to the modeling of their neighbor's systems that is necessary to execute state estimation or power flow applications. Currently only one profile, the Equipment Profile, has been defined. A companion standard, IEC 61970-552, defines the CIM XML Model Exchange Format based on the Resource Description Framework (RDF) Schema specification language which is recommended to be used to transfer power system model data for the IEC 61970-452 profile.

[IEC 61970-452:2015](https://standards.iteh.ai/catalog/standards/sist/3c8f63c6-a80e-4029-9bfb-69016366bd81/iec-61970-452-2015)

<https://standards.iteh.ai/catalog/standards/sist/3c8f63c6-a80e-4029-9bfb-69016366bd81/iec-61970-452-2015>

ENERGY MANAGEMENT SYSTEM APPLICATION PROGRAM INTERFACE (EMS-API) –

Part 452: CIM model exchange specification

1 Scope

This part of IEC 61970 is a member of the IEC 61970-450 to -499 series that, taken as a whole, defines at an abstract level the content and exchange mechanisms used for data transmitted between control centers and/or control center components.

The purpose of this document is to rigorously define the subset of classes, class attributes, and roles from the CIM necessary to execute state estimation and power flow applications. The North American Electric Reliability Council (NERC) Data Exchange Working Group (DEWG) Common Power System Modeling group (CPSM) produced the original data requirements, which are shown in Annex C. These requirements are based on prior industry practices for exchanging power system model data for use primarily in planning studies. However, the list of required data has been extended to facilitate a model exchange that includes parameters common to breaker-oriented applications. Where necessary this document establishes conventions, shown in Clause 5, with which an XML data file must comply in order to be considered valid for exchange of models.

This document is intended for two distinct audiences, data producers and data recipients, and may be read from two perspectives.

From the standpoint of model export software used by a data producer, the document describes a minimum subset of CIM classes, attributes, and associations which must be present in an XML formatted data file for model exchange. This standard does not dictate how the network is modelled, however. It only dictates what classes, attributes, and associations are to be used to describe the source model as it exists. All classes, attributes, and associations not explicitly labeled as recommended or conditionally required should be considered required with the following caveat. Consider, as an example, the situation in which an exporter produces an XML data file describing a small section of the exporter's network that happens to contain no breakers. The resulting XML data file should, therefore, not contain an instance of the Breaker class. On the other hand, if the section of the exporter's network does contain breakers, the resulting data file should contain instances of the Breaker class that include, at a minimum, the attributes and roles described herein for Breakers. Furthermore, it should be noted that an exporter may, at his or her discretion, produce an XML data file containing additional class data described by the CIM RDF Schema but not required by this document provided these data adhere to the conventions established in Clause 5.

From the standpoint of the model import used by a data recipient, the document describes a subset of the CIM that importing software must be able to interpret in order to import exported models. As mentioned above, data providers are free to exceed the minimum requirements described herein as long as their resulting data files are compliant with the CIM RDF Schema and the conventions established in Clause 5. The document, therefore, describes additional classes and class data that, although not required, exporters will, in all likelihood, choose to include in their data files. The additional classes and data are labeled as recommended or as not required to distinguish them from their required counterparts. Please note, however, that data importers could potentially receive data containing instances of any and all classes described by the CIM RDF Schema.

2 Normative references

The following documents, in whole or in part, are normatively referenced in this document and are indispensable for its application. For dated references, only the edition cited applies. For undated references, the latest edition of the referenced document (including any amendments) applies.

NOTE For general glossary definitions, see IEC 60050, *International Electrotechnical Vocabulary*.

IEC 61970-301:2013, *Energy management system application program interface (EMS-API) – Part 301: Common information model (CIM) base*

IEC 61970-501, *Energy management system application program interface (EMS-API) – Part 501: Common Information Model Resource Description Framework (CIM RDF) schema*

3 Overview of data requirements

3.1 Overview

An extensive discussion of the model exchange use cases can be found in Annex A. In all cases, the purpose of this standard is:

- To improve the accuracy of power system models used in critical systems, particularly the representation of parts of the network outside the primary domain of the system in question.
- To achieve consistency among the models used by the various systems that play a role in operating or planning the interconnection.
- To reduce the overall cost of maintaining critical models used in operating or planning an interconnection.

The classes, attributes, and associations identified in this document represent the minimum subset of the full CIM model necessary to exchange sufficient power system data to support state estimation and power flow.

3.2 General requirements

The following requirements are general in nature or involve multiple classes. Additional requirements are defined in the sections for the individual classes.

- The cardinality defined in the CIM model shall be followed, unless a different cardinality is explicitly defined in this document. For instance, the cardinality on the association between VoltageLevel and BaseVoltage indicates that a VoltageLevel shall be associated with one and only one BaseVoltage, but a BaseVoltage can be associated with zero to many VoltageLevels.
- Associations between classes referenced in this document and classes not referenced here are not required regardless of cardinality. For instance, the CIM requires that a HydroGeneratingUnit be associated with a HydroPowerPlant. Because the HydroPowerPlant class is not included in this document the association to HydroPowerPlant is not considered mandatory in this context.
- The attribute “name” inherited by many classes from the abstract class IdentifiedObject is not required to be unique. The RDF ID defined in the data exchange format is the only unique and persistent identifier used for this data exchange. The attribute IdentifiedObject.name is, however, always required. The additional attribute of IdentifiedObject, aliasName, is not required.
- Although not defined within this profile, the IdentifiedObject.mRID attribute should be used as the RDF ID. The RDF ID can not begin with a number. An underscore should be added as the first character if necessary. The RDF ID shall be globally unique. A prefix may be

added, if necessary, to ensure global uniqueness, but the RDF ID including the prefix shall be within the maximum character limit specified below.

- The maximum character length of names and identifiers are listed below.
 - `rdf:ID` – 60 characters maximum
 - `IdentifiedObject.name` – 32 characters maximum
 - `IdentifiedObject.aliasname` – 40 characters maximum
- To maintain a consistent naming hierarchy, each `Substation` shall be contained by a `SubGeographicalRegion` and each `SubGeographicalRegion` shall be contained by one and only one `GeographicalRegion`.
- Equipment defined without connectivity, because the associated `Terminal(s)` are not connected to `ConnectivityNodes` is allowed, for instance a `ShuntCompensator` whose `Terminal` is not associated to a `ConnectivityNode`.
- UTF-8 is the standard for file encoding. UTF-16 is not supported.
- Instance data to be exchanged shall make use of the most detailed class possible. The classes `GeneratingUnit`, `Switch`, and `EnergyConsumer` should only be used if the information to determine the more detailed class (`ThermalGeneratingUnit`, `HydroGeneratingUnit`, `Breaker`, `Disconnecter`, etc.) is not available.

3.3 Transformer modeling

A two winding `PowerTransformer` has two `PowerTransformerEnds`. This gives the option to specify the impedance values for the equivalent pi-model completely at one end or split them between the two ends. The impedances shall be specified at the primary voltage side as shown in Figure 1.

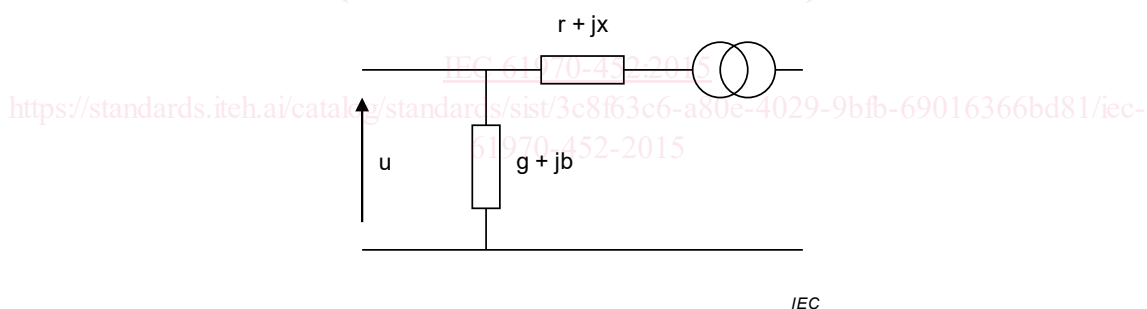
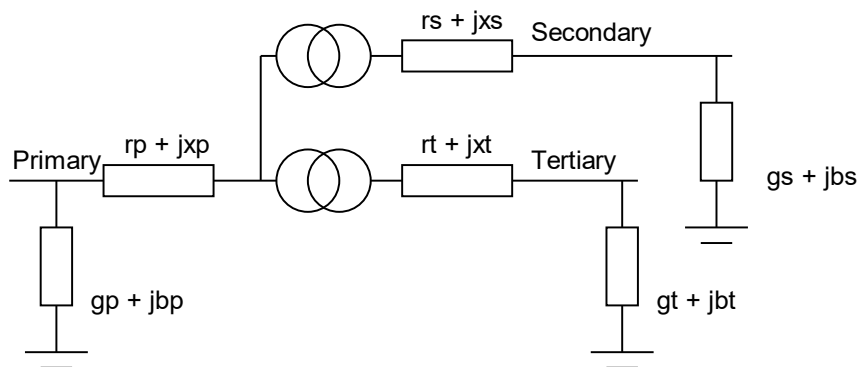

Figure 1 – Two winding transformer impedance

A three winding `PowerTransformer` has three `PowerTransformerEnds`. The equivalent pi-model corresponds to three ends connected in wye configuration as shown below. The impedance values for a three winding transformer are specified on each of the three `TransformerWindings`. Each of the ends has series impedances $r_n + jx_n$ and shunt $g_n + jb_n$ where n is: p for primary, s for secondary and t for tertiary as shown in Figure 2.



IEC

Figure 2 – Three winding transformer impedance

Additional requirements related to transformer modeling are listed below.

- Each PowerTransformer and its associated PowerTransformerEnds and tap changers (RatioTapChanger, PhaseTapChangerLinear, PhaseTapChangerSymetrical, and PhaseTapChangerAsymetrical) shall be contained within one substation. For the case of a transformer that connects two substations, however, the terminal of one of the PowerTransformerEnds can be connected to a ConnectivityNode defined in another substation. In this case, the PowerTransformer, the PowerTransformerEnds, the tap changers are still all defined in one substation.
- A PowerTransformer shall be contained by a Substation. A PowerTransformerEnd shall be contained by a PowerTransformer. A RatioTapChanger, PhaseTapChangerLinear, PhaseTapChangerSymetrical, and PhaseTapChangerAsymetrical shall be contained by a PowerTransformerEnd.
- Each PowerTransformer shall have at least two and no more than three PowerTransformerEnds. Each PowerTransformerEnd can have at most one tap changer (RatioTapChanger, PhaseTapChangerLinear, PhaseTapChangerSymetrical, or PhaseTapChangerAsymetrical). If a PowerTransformerEnd does not have an associated tap changer, the end should be considered to have a fixed tap.

Multiple types of regulating transformers are supported by the CIM model. Depending on the regulation capabilities, the effects of tap movement will be defined using the RatioTapChanger class, PhaseTapChangerLinear class, PhaseTapChangerSymetrical class, or PhaseTapChangerAsymetrical class. Each of these classes are subtypes of the TapChanger class. The use of the various subtypes is explained in IEC 61970-301.

3.4 Modeling authorities

From the use cases for model exchange detailed in Annex A, it is clear that most situations involve multiple entities that shall cooperate. In these situations, it is very important to establish which entity has the authority for modeling each region or set of data objects. For this purpose we use the concepts of ModelingAuthority and ModelingAuthoritySet. ModelingAuthority and ModelingAuthoritySet are not defined as classes in the normative portion of the CIM. When multiple modeling entities are involved, each modeled object is assigned to a ModelingAuthoritySet. A ModelingAuthority can be responsible for one or more ModelingAuthoritySets. A more detailed description of the use ModelingAuthorities and ModelingAuthoritySets can be found in Annex B. When using the concept of ModelingAuthoritySets, a single file shall contain only data objects associated with a single ModelingAuthoritySet.