

INTERNATIONAL  
STANDARD

**ISO**  
**5435**

Third edition  
1994-08-01

---

---

**Rubber compounding ingredients —  
Carbon black — Determination of tinting  
strength**

**iTeh STANDARD PREVIEW**

*(Ingredients de mélange du caoutchouc — Noir de carbone —  
Détermination du pouvoir colorant*

[ISO 5435:1994](#)

<https://standards.iteh.ai/catalog/standards/sist/f848768d-3edb-4d41-9935-a1f6d4f41848/iso-5435-1994>



Reference number  
ISO 5435:1994(E)

## Foreword

ISO (the International Organization for Standardization) is a worldwide federation of national standards bodies (ISO member bodies). The work of preparing International Standards is normally carried out through ISO technical committees. Each member body interested in a subject for which a technical committee has been established has the right to be represented on that committee. International organizations, governmental and non-governmental, in liaison with ISO, also take part in the work. ISO collaborates closely with the International Electrotechnical Commission (IEC) on all matters of electrotechnical standardization.

Draft International Standards adopted by the technical committees are circulated to the member bodies for voting. Publication as an International Standard requires approval by at least 75 % of the member bodies casting a vote.

International Standard ISO 5435 was prepared by Technical Committee ISO/TC 45, *Rubber and rubber products*, Subcommittee SC 3, *Raw materials (including latex) for use in the rubber industry*.

This third edition cancels and replaces the second edition (ISO 5435:1991). The only technical change in this edition is the addition of an extra line (for 0,140 g of carbon black) in table 1.

© ISO 1994

All rights reserved. Unless otherwise specified, no part of this publication may be reproduced or utilized in any form or by any means, electronic or mechanical, including photocopying and microfilm, without permission in writing from the publisher.

International Organization for Standardization  
Case Postale 56 • CH-1211 Genève 20 • Switzerland

Printed in Switzerland

# Rubber compounding ingredients — Carbon black — Determination of tinting strength

**WARNING** — Persons using this International Standard should be familiar with normal laboratory practice. The standard does not purport to address all of the safety problems, if any, associated with its use. It is the responsibility of the user to establish appropriate safety and health practices and to ensure compliance with any national regulatory conditions.

## 1 Scope

This International Standard specifies a method for the determination of the tinting strength of carbon black relative to an industry tint reference black.

The method is based on the use of three different commercial instruments. Other instruments may be used but they shall have at least equivalent performance.

NOTE 1 Details of the manufacturers of the Erichsen Tint Tester are given in the relevant clause of this International Standard. The Densichron reflectometer and the Meeco Colormaster are no longer available commercially, but the methods are included for the benefit of users of these instruments.

## 2 Normative references

The following standards contain provisions which, through reference in this text, constitute provisions of this International Standard. At the time of publication, the editions indicated were valid. All standards are subject to revision, and parties to agreements based on this International Standard are encouraged to investigate the possibility of applying the most recent editions of the standards indicated below. Members of IEC and ISO maintain registers of currently valid International Standards.

ISO 471:—<sup>1)</sup>, *Rubber — Times, temperatures and humidities for conditioning and testing.*

ISO 1126:1992, *Rubber compounding ingredients — Carbon black — Determination of loss on heating.*

ISO 6809:1989, *Rubber compounding ingredients — Carbon black — Standard reference blacks.*

## 3 Principle

An industry tint reference black (ITRB) is mixed with zinc oxide and a liquid plasticizer. The paste obtained is mulled and homogenized, then spread as a layer of regular thickness. Its light reflectance is measured with a reflectometer sensitive to different shades of grey.

A test sample is mixed and its light reflectance measured in the same manner and, from the two light reflectance values, the relative tinting strength of the sample is determined.

## 4 Reagents

**4.1 Soyabean oil epoxide**, for use as plasticizer, of relative density 0,92 to 0,99. It is essential that the soyabean oil epoxide is maintained above 20 °C to prevent turbidity which leads to erroneous results.

**4.2 Industry tint reference black (ITRB)<sup>2)</sup>**.

1) To be published. (Revision of ISO 471:1983 and ISO 1826:1981)

2) ITRB is available from Degussa Carbon Black Corporation, 1034 S. Broadway, Akron, Ohio 44311, USA.

**4.3 Zinc oxide**, e.g. industry tint zinc oxide (ITZnO)<sup>3)</sup>. Other zinc oxides may be used, provided that they give the same results.

**4.4 Standard reference blacks**, conforming with the requirements of ISO 6809.

## 5 Apparatus

**5.1 Analytical balance**, accurate to 0,1 mg.

**5.2 Automatic muller**.

**5.3 Oven**, capable of being maintained at  $105\text{ °C} \pm 2\text{ °C}$  or  $125\text{ °C} \pm 2\text{ °C}$ .

**5.4 Flexible palette knives**, preferably tapered, of stainless steel, 100 mm to 150 mm long.

**5.5 Syringe**, automatic filling, accurate to  $0,02\text{ cm}^3$ .

**5.6 Light-measuring instrument**, sensitive to variations in light reflectance of shades of grey (see under appropriate procedure).

**5.7 Paste application apparatus** (see under appropriate procedure).

## 6 Test conditions

The test should preferably be carried out under standard temperature and humidity conditions as specified in ISO 471, i.e.  $23\text{ °C} \pm 2\text{ °C}$  and  $(50 \pm 5)\%$  relative humidity or  $27\text{ °C} \pm 2\text{ °C}$  and  $(65 \pm 5)\%$  relative humidity.

## 7 Procedure

### 7.1 Preparation of pastes

**7.1.1** Dry the ITZnO (4.3) and carbon black in accordance with ISO 1126. Just sufficient ITRB (4.2) should be dried, as re-drying on a future occasion is not recommended.

**7.1.2** Weigh the required amount of carbon black or ITRB (see 7.1.10 and 7.1.11) to the nearest 1 mg (crushing of pelleted carbon blacks is beneficial). Weigh  $3,750\text{ g} \pm 1\text{ mg}$  of the ITZnO.

**7.1.3** Using the syringe (5.5), place  $2,2\text{ cm}^3$  of the plasticizer (4.1) in the centre of the lower glass plate of the automatic muller (5.2).

**7.1.4** Place the ITZnO and carbon black in the centre of the pool of plasticizer.

**7.1.5** Mix the three materials thoroughly with the palette knife (5.4).

**7.1.6** Set the muller to a pressure of 0,017 MPa between the plates (445 N force when using 18,4 cm diameter plates), by placing the extra masses, supplied with the instrument, on the arm. Close and mull for 25 revolutions.

**7.1.7** Open the plates, scrape the upper plate with a palette knife to remove as much paste as possible and transfer it to the lower plate. Then, with the lower plate rotating, use the palette knife to spread the paste to a flattened circle on the plate, and work all the paste to the centre. Repeat this step twice more.

**7.1.8** Repeat steps 7.1.6 and 7.1.7 three times, i.e. for a total of four  $\times$  25 revolutions.

**7.1.9** Remove the paste to a clean smooth surface.

Pastes should be tested immediately (in no case shall they be kept for more than 24 h).

**7.1.10** For calibration, prepare pastes in duplicate using the masses of carbon black in table 1.

**Table 1**

ITRB g	Calibration tint value %
0,090	90 units
0,100	100 units
0,110	110 units
0,120	120 units
0,130	130 units
0,140	140 units

**7.1.11** For determinations of tinting strength of test samples, prepare duplicate pastes with

0,100 g of N 100 to N 400 series carbon blacks;

0,200 g of N 500 to N 700 series carbon blacks.

### 7.2 Individual procedures

Instructions are given relating to different types of commercial instrument (5.6).

3) ITZnO is available from Titan Specialties Inc., SWY 152W, P.O. Box 2316, Pampa, Texas 79066-2316, USA.

Other instruments may be used provided that they have similar performance.

All instruments shall be operated in accordance with the manufacturer's instructions.

## 7.2.1 Measurements using the Erichsen Tint Tester

### 7.2.1.1 Apparatus

NOTE 2 For general details, see 5.1 to 5.5.

#### 7.2.1.1.1 Erichsen Tint Tester<sup>4)</sup>, model 517 or 527.

NOTE 3 Model 527 has a specially designed head which keeps the paste off the lens.

**7.2.1.1.2 Film applicator**, 0,08 mm gauge depth, to give 0,04 mm wet film thickness.

**7.2.1.1.3 Glass plate**, approximately 750 mm × 500 mm × 10 mm.

### 7.2.1.2 Calibration

**7.2.1.2.1** Switch on the instrument and adjust in accordance with the manufacturer's instructions. Clean the glass plate (7.2.1.1.3) with a tissue to remove any dust particles or film. Using a clean palette knife (5.4), place a portion of one of the mulled pastes with 100 % calibration tint value (7.1.10) at the top edge of the glass plate and smear it almost to the bottom edge. Using the film applicator (7.2.1.1.2), draw down the paste to the bottom edge in about 2 s to 3 s.

**7.2.1.2.2** Place the reflectometer head on the drawdown on the paste.

Adjust the meter to read 3,0 for at least three readings, all taken at 75 mm or more from the top of the drawdown. If the results are variable, gather up the paste and make another drawdown.

**7.2.1.2.3** Make a duplicate drawdown of the duplicate paste as in 7.2.1.2.1. Without altering the setting, take three readings from the duplicate paste. If the results are variable, gather up the paste and make another drawdown. These pastes are acceptable if a reading of  $3,0 \pm 0,03$  is obtained from the duplicate paste.

NOTE 4 It is beneficial to have the two drawdowns side by side.

**7.2.1.2.4** If these pastes are acceptable, blend the two together using a palette knife.

**7.2.1.2.5** If the pastes are not acceptable, prepare a further paste and determine its reflectance using the same procedure.

**7.2.1.2.6** Blend together whichever two of these three pastes do not differ by more than 0,03.

**7.2.1.2.7** Determine the reflectance values of the remaining calibration pastes (see 7.1.10), taking three readings from each paste.

**7.2.1.2.8** Plot a graph of the average readings versus the calibration tint values or determine the equation to give the best fit.

NOTE 5 The equation is not necessarily linear.

**7.2.1.2.9** Periodically check the proper calibration and standardization of the equipment, reagents, materials and method, as required, using standard reference blacks (4.4).

### 7.2.1.3 Determination of tinting strength of a test sample

**7.2.1.3.1** Prepare duplicate pastes of 100 % calibration tint values as described in 7.1.1 to 7.1.10.

**7.2.1.3.2** Prepare the paste and set the instrument to 3,0 as described in 7.2.1.2.1 to 7.2.1.2.6.

**7.2.1.3.3** Using the correct mass of the test sample (see 7.1.11), prepare duplicate pastes as described in 7.1.1 to 7.1.9.

**7.2.1.3.4** Determine the reflectance values of the pastes containing the test sample, taking three readings with each.

**7.2.1.3.5** Determine the tinting strength of the test sample by using the graph or equation determined in 7.2.1.2.8.

4) The Erichsen Tint Tester is the trade-name of an apparatus supplied by Erichsen GmbH u. Co KG, 5870 Hemer-Sundwig, Germany. This information is given for the convenience of users of this International Standard and does not constitute an endorsement by ISO of the apparatus named. Equivalent products may be used if they can be shown to lead to the same results.

## 7.2.2 Measurements using the Densichron reflectometer (film drawdown and roller spreader methods)

### 7.2.2.1 Apparatus

NOTE 6 For general details, see 5.1 to 5.5.

**7.2.2.1.1 Densichron reflectometer**, for the film drawdown method.

**7.2.2.1.2 Film applicator**, 0,08 mm gauge depth, to give 0,04 mm wet film thickness.

**7.2.2.1.3 Glass plate**, approximately 750 mm × 500 mm × 10 mm.

**7.2.2.1.4 Tint roller spreader**, for the roller spreader method.

### 7.2.2.2 Calibration

#### 7.2.2.2.1 Film drawdown method

**7.2.2.2.1.1** Clean the glass plate (7.2.2.1.3) with a tissue to remove any dust particles or film. Using a clean palette knife (5.4), place a portion of one of the mulled pastes with 100 % calibration tint value (7.1.10) at the top edge of the glass plate and smear it almost to the bottom edge. Using the film applicator (7.2.2.1.2), draw down the paste to the bottom edge in about 2 s to 3 s.

**7.2.2.2.1.2** Set the range switch to 2 and operate with no filter in the reflection head.

Use 4,76 mm aperture if head No. 3882A is used.

Place the reflectometer head on the drawdown of the paste. Adjust the meter reading to read 80 % for at least three readings, all taken at 75 mm or more from the top of the drawdown. If the results are variable, gather up the paste and make another drawdown.

**7.2.2.2.1.3** Make a duplicate drawdown of the duplicate paste as in 7.2.2.2.1.1. Without altering the setting, take three readings from the duplicate paste. If the results are variable, gather up the paste and make another drawdown. These pastes are acceptable if a reading of  $80 \pm 0,5$  is obtained from the duplicate paste.

NOTE 7 It is beneficial to have the two drawdowns side by side.

**7.2.2.2.1.4** If these pastes are acceptable, blend the two together using a palette knife.

**7.2.2.2.1.5** If the pastes are not acceptable, prepare another paste containing 0,100 g of ITRB and check using the same procedure.

**7.2.2.2.1.6** Blend together whichever two of these three pastes do not differ by more than 0,5 %.

**7.2.2.2.1.7** Determine the reflectance values of the remaining calibration pastes (see 7.1.10), taking three readings from each paste.

#### 7.2.2.2.2 Roller spreader method

**7.2.2.2.2.1** Using a clean palette knife (5.4) place a portion of one of the mulled pastes of 100 % calibration tint value (7.1.10) on the clean turning roller of the tint roller spreader (7.2.2.1.4). Turn the range switch from 0 to position 2. Using the calibration control, adjust the meter to read 80 %. Turn the range switch to position 0. Clean the roller and applicator. Place a portion of the other paste having 100 % calibration tint value on the turning roller and turn the range switch to position 2 without altering the calibration control.

**7.2.2.2.2.2** The pastes are acceptable if readings of  $80 \pm 0,5$  are obtained.

**7.2.2.2.2.3** If the pastes are not acceptable, prepare another paste containing 0,100 g ITRB and check using the same procedure.

**7.2.2.2.2.4** Blend together whichever two of these three pastes do not differ by more than 0,5 %.

**7.2.2.2.2.5** Determine the reflectance values of the remaining calibration paste (see 7.1.10).

**7.2.2.2.2.6** Plot a graph of the average readings versus the calibration tint values or determine a linear equation by the method of least squares.

**7.2.2.2.2.7** Periodically check the proper calibration and standardization of the equipment, reagents, materials and method, as required, using standard reference blacks (4.4).

### 7.2.2.3 Determination of tinting strength of a test sample

**7.2.2.3.1** Prepare duplicate pastes of 100 % calibration tint value as described in 7.1.1 to 7.1.10.

**7.2.2.3.2** Prepare the paste and set the instrument to 80 % as described in 7.2.2.2.1.1 to 7.2.2.2.1.6 or 7.2.2.2.2.1 to 7.2.2.2.2.4.

**7.2.2.3.3** Using the correct mass of the test sample (see 7.1.11), prepare duplicate pastes as described in 7.1.1 to 7.1.9.

**7.2.2.3.4** Determine the reflectance values of the pastes containing the test samples, taking three readings with each.

**7.2.2.3.5** Determine the tinting strength of the test sample by using the graph or equation determined in 7.2.2.2.6.

## 7.2.3 Measurement using the Meeco Colormaster

### 7.2.3.1 Apparatus

NOTE 8 For general details, see 5.1 to 5.5.

#### 7.2.3.1.1 Meeco Colormaster.

**7.2.3.1.2 Glass plate**, approximately 750 mm × 500 mm × 10 mm.

**7.2.3.1.3 Glass slides**, of dimensions 75 mm × 50 mm × (1,22 mm ± 0,05 mm).

**7.2.3.1.4 Glass rod**, approximately 6,5 mm × 250 mm.

**7.2.3.1.5 Slide preparation apparatus** (see figure 1).

### 7.2.3.2 Calibration

**7.2.3.2.1** Clean the glass slide (7.2.3.1.3) with a tissue to remove any dust particles or film. Using a clean palette knife (5.4) place a small portion of one of the mulled pastes with 100 % calibration tint value (7.1.10) along the edge of the slide.

**7.2.3.2.2** Place the slide in the slide preparation plate with the paste at the open end. Draw the glass rod (7.2.3.1.4) across the sample from the open end towards the closed end three times, uniformly spreading the paste on to the slide (see figure 1).

NOTE 9 It is not necessary to cover the full length of the slide. (The glass rod resting on the two slide strips of masking tape gives a film thickness of 0,5 mm — see figure 1.)

**7.2.3.2.3** Use the green filter only. Place the prepared slide (see 7.2.3.2.2) with the paste side up centrally over the left front hole and immediately read the reflectance. Make a duplicate slide of the duplicate paste in the way specified in 7.2.3.2.1 and

7.2.3.2.2 and measure the reflectance from the slide. The pastes are acceptable if their reflectance is within ± 0,6 %.

**7.2.3.2.4** If the pastes are not acceptable, prepare another paste containing 0,100 g of ITRB and check using the same procedure.

**7.2.3.2.5** Blend together whichever two of these three pastes do not differ by more than 0,6 %.

**7.2.3.2.6** Determine the reflectance values of the remaining calibration pastes (see 7.1.10).

**7.2.3.2.7** Plot a graph of the average readings versus the calibration tint values or determine a linear equation by the method of least squares.

**7.2.3.2.8** Periodically check the proper calibration and standardization of the equipment, reagents, materials and method, as required, using standard reference blacks (4.4).

### 7.2.3.3 Determination of tinting strength of test sample

**7.2.3.3.1** Prepare duplicate pastes of 100 % calibration tint value as described in 7.1.1 to 7.1.10 and, using the method in 7.2.3.2.3, take a reading for each.

**7.2.3.3.2** Using the correct mass of the test sample (see 7.1.11), prepare duplicate pastes as described in 7.1.1 to 7.1.9.

**7.2.3.3.3** Take readings from these pastes as described in 7.2.3.2.3 and calculate the tinting strength using the graph or equation determined as in 7.2.3.2.6.

## 8 Expression of results

Express the percentage tint value to the nearest 0,1 tint unit.

NOTE 10 Only if the calibration graph is a straight line or if a linear equation determined by the method of least squares gives results within 0,8 units of the calibration values, then the following formula can be used:

$$T = \frac{R}{S} \times 100$$

where

*T* is the percentage tint value;

*R* is the reflectance of the paste with 100 % calibration tint value;

*S* is the reflectance of the test sample.

For N 500, N 600 and N 700 series carbon blacks, where 0,2 g of test sample has been used, divide the result by 2. However, if a statistical equation is used to correct measured tint values, the values for N 500, N 600 and N 700 series carbon blacks shall be corrected before dividing the result by 2.

## 9 Test report

The test report shall include the following information;

- a) a reference to this International Standard;
- b) all details necessary for the identification of the sample;
- c) all details necessary for the identification of the primary reference black, if not ITRB;
- d) the temperature used for drying the zinc oxide and the carbon black;
- e) the reflectance instrument used;
- f) the method of preparing the paste for measurement;
- g) the results of replicate tests;
- h) any deviation from the procedures specified in this International Standard.

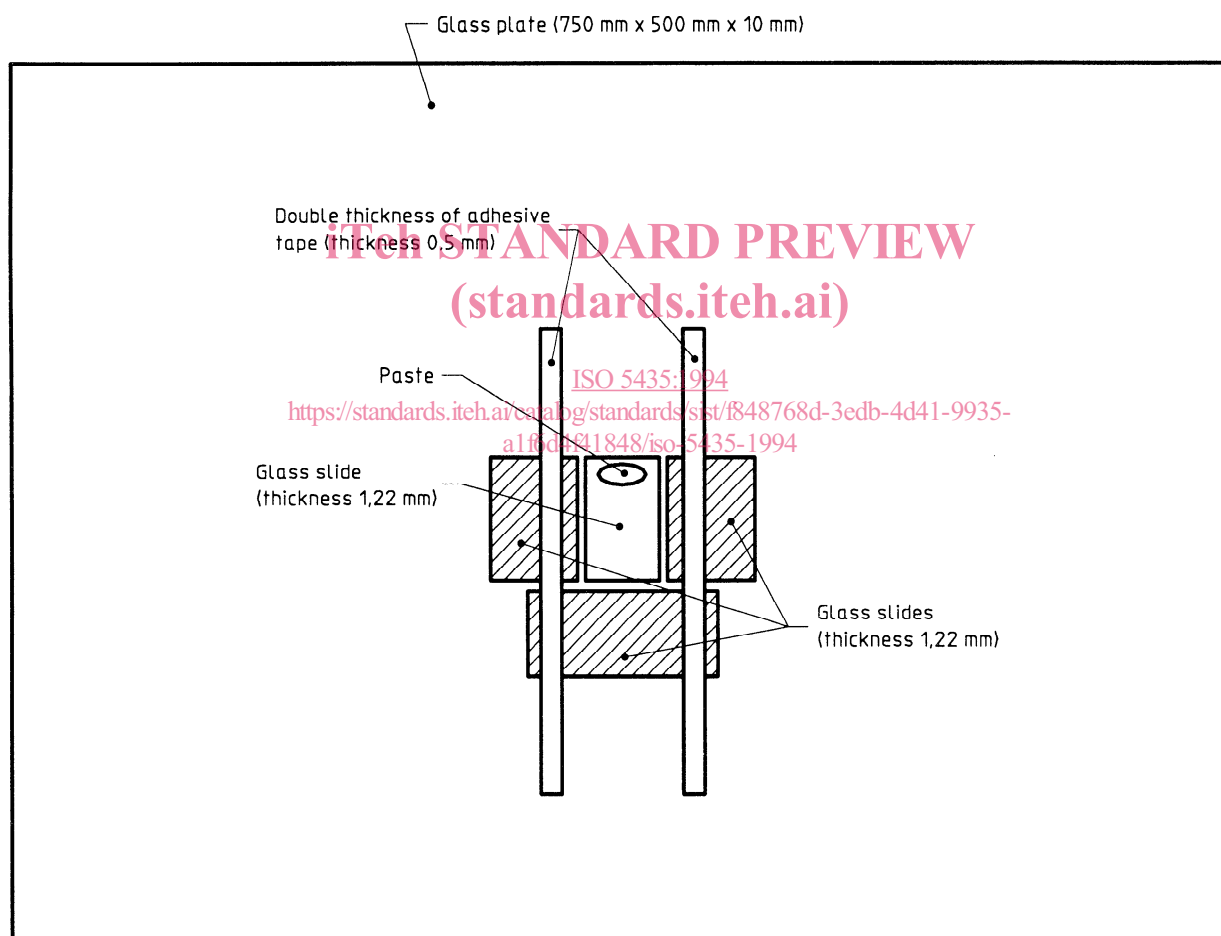

Figure 1 — Slide preparation apparatus for Meeco Colormaster



**iTeh STANDARD PREVIEW**  
This page intentionally left blank  
**(standards.iteh.ai)**

[ISO 5435:1994](#)

<https://standards.iteh.ai/catalog/standards/sist/f848768d-3edb-4d41-9935-a1f6d4f41848/iso-5435-1994>