



Designation: C 961 – 01

## Standard Test Method for Lap Shear Strength of Hot-Applied Sealants<sup>1</sup>

This standard is issued under the fixed designation C 961; the number immediately following the designation indicates the year of original adoption or, in the case of revision, the year of last revision. A number in parentheses indicates the year of last approval. A superscript epsilon ( $\epsilon$ ) indicates an editorial change since the last revision or reapproval.

### 1. Scope

1.1 This test method covers a laboratory procedure for determining the lap shear strength of hot-applied sealants, hereinafter referred to as sealant. It also provides information on the adhesive bond of the sealants to the tested substrates.

1.2 The values stated in SI units are to be regarded as the standard. The values given in parentheses are for information only.

1.3 *This standard does not purport to address all of the safety concerns, if any, associated with its use. It is the responsibility of the user of this standard to establish appropriate safety and health practices and determine the applicability of regulatory limitations prior to use.*

1.4 The subcommittee with jurisdiction of this standard is not aware of any similar or equivalent ISO standard.

### 2. Referenced Documents

2.1 *ASTM Standards:*

C 717 Terminology of Building Seals and Sealants<sup>2</sup>

### 3. Terminology

3.1 *Definitions:*

3.1.1 The definitions of the following terms used in this test method are found in Terminology C 717, 4.1: adhesive failure, cohesive failure, hot applied sealant, sealant, and substrate.

3.2 *Definitions of Terms Specific to This Standard:*

3.2.1 The following definitions of terms are found in Terminology C 717, 4.2: applicator and specified temperature.

### 4. Summary of Test Method

4.1 The sealant is placed between two glass substrates. The sample is placed in a tensile tester and pulled at a constant rate to failure. The maximum shear force and mode of failure is noted. Maximum shear stress is calculated and reported.

### 5. Significance and Use

5.1 Sealants are generally subjected to longitudinal and lateral shear stresses in end use applications. This test method

measures the cohesive strength of sealants when subjected to shear stresses, and also provides information regarding the adhesive bond to the substrates being tested.

### 6. Apparatus

6.1 *Applicator<sup>3</sup> or Oven*, capable of maintaining the sealant within  $\pm 2.8^\circ\text{C}$  ( $\pm 5^\circ\text{F}$ ) of the specified temperature.

6.2 *Substrates*, of annealed glass that are 25.4 mm wide by 76.2 mm long and 6.35 mm thick (1 by 3 by 0.25 in.). Other substrates may be used when specified (Fig. 1).

6.3 *Template*, to provide 3.18-mm ( $\frac{1}{8}$ -in.) sealant thickness (Fig. 2).

6.4 *Hot Knife*.

6.5 *Tension Testing Machine*, capable of pulling a specimen at a rate of 12.7 mm (0.5 in.)/min.

### 7. Sampling

7.1 Sealant shall be free of external surface contaminants such as talc, oil, dust, and moisture. Handling of the sealant surfaces in contact with the substrate shall be minimized.

7.2 A 1.0-kg (2.2-lb) representative sample shall be taken from bulk stock for testing.

### 8. Test Specimens

8.1 Prepare six test specimens from the bulk sample by using the applicator or the oven method.

8.1.1 *Applicator Method:*

8.1.1.1 Clean the substrate surface with soap and water followed by a water rinse and solvent wipe with methyl ethyl ketone (MEK).

NOTE 1—At the request of the sealant manufacturer, an alternative cleaning procedure may be used.

8.1.1.2 Using an appropriate die, apply a 25.4 by 25.4-mm (1 by 1-in.) layer of sealant onto one end of the substrate surface at a thickness that when compressed will comply with 8.1.1.4. Substrates shall be at a temperature of  $23 \pm 2^\circ\text{C}$ ,  $50 \pm 10\%$  relative humidity ( $73.4 \pm 3.6^\circ\text{F}$ ). Apply the sealant at the specified temperature  $\pm 2.8^\circ\text{C}$  ( $\pm 5^\circ\text{F}$ ) (Fig. 1).

<sup>1</sup> This test method is under the jurisdiction of ASTM Committee C24 on Building Seals and Sealants and is the direct responsibility of Subcommittee C24.30 on Adhesion.

Current edition approved June 10, 2001. Published July 2001.. Originally published as C 961 – 81. Last previous edition C 961 – 97.

<sup>2</sup> *Annual Book of ASTM Standards*, Vol 04.07.

<sup>3</sup> The sole source of supply of the apparatus known to the committee at this time is the Pyles Bulk Melters, Pyles Industries, Inc., 28990 Wixom Rd., Wixom, MI 48096. If you are aware of alternative suppliers, please provide this information to ASTM Headquarters. Your comments will receive careful consideration at a meeting of the responsible technical committee,<sup>1</sup> which you may attend.

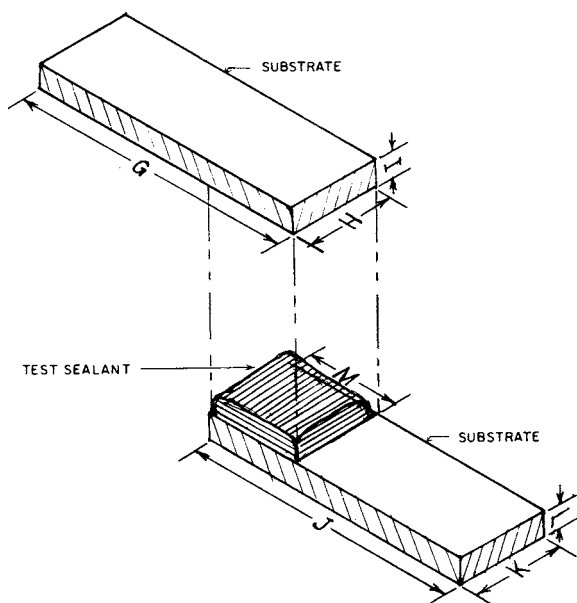

Dimension	Length	
	mm	in.
G, J	76.2 ± 0.25	(3.00 ± 0.01)
H, K, M	25.4 ± 0.25	(1.00 ± 0.01)
I, L	6.35 ± 0.10	(0.250 ± 0.004)

FIG. 1 Assembly of Test Sealant on Substrates

8.1.1.3 Immediately after sealant application place a second substrate onto the sealant to form an overlap of 6.45 cm<sup>2</sup>(1 in.<sup>2</sup>) (Fig. 1).

8.1.1.4 Using a template (Fig. 2), compress the overlaid sealant to form the 3.18-mm (1/8-in.) thick overlap (Fig. 3).

8.1.1.5 Remove excess sealant from the specimen with a hot knife.

8.1.2 *Oven Method:*

8.1.2.1 Clean the substrate surface with soap and water followed by a water rinse and solvent wipe with MEK (Note 1).

8.1.2.2 Place sufficient sealant onto the substrate so that when compressed, a 6.45-cm<sup>2</sup>(1-in.<sup>2</sup>) overlap that will comply with 8.1.2.4 is obtained.

8.1.2.3 Separately place both the substrate with sealant and the overlapping substrate into an oven and condition for 30 min at the specified temperature.

8.1.2.4 Immediately upon removing the substrates from the oven, place the second substrate onto the sealant on the first substrate (Fig. 1). Using the template (Fig. 2), compress the overlaid sealant to form a 3.18-mm (1/8-in.) thick overlap (Fig. 3).

8.1.2.5 Remove excess sealant from the specimen with a hot knife.

9. Conditioning

9.1 Condition all test specimens at 23 ± 2°C (73.4 ± 3.6°F) for at least 24 h prior to testing.

9.2 Additional conditioning may be done as specified by mutual agreement between the purchaser and sealant manufacturer.

10. Procedure

10.1 Attach each specimen to the jaws of the tension testing machine and separate at a crosshead speed of 12.7 mm (0.5 in.)/min to failure (separation) (Fig. 4). Align the testing machine jaws to prevent cocking of test assembly.

10.2 Visually inspect and record the mode of bond failure (cohesive or adhesive) and the approximate percentage of each.

10.3 Observe and record the maximum shear force in newtons (or pounds-force).

11. Calculation

11.1 Calculate the maximum shear stress, *S*, as follows:

$$S = F/A$$

where:

*S* = maximum shear stress, Pa (or lbf/in.<sup>2</sup>),

*F* = maximum shear force, N (or lbf), and

*A* = contact area of the specimen with one substrate, m<sup>2</sup>(or in.<sup>2</sup>).

11.2 Average the results of the six specimens tested.

12. Report

12.1 Report the following information:

12.1.1 Equipment used to apply the sealant,

12.1.2 Average maximum lap shear stress and range of values in Pa (or psi),

12.1.3 Any substrate deformation during testing and degree of deformation,

12.1.4 Type of failure, adhesive, or cohesive, and percentage of each,

12.1.5 Sealant application temperature,

12.1.6 Oven temperature and time of conditioning, if different from 8.1.2.3,

12.1.7 Substrates tested,

12.1.8 Substrate cleaning procedure if different from 8.1.1.1 and 8.1.2.1, and

12.1.9 Any additional conditioning as allowed by 9.2.

13. Precision and Bias <sup>4</sup>

13.1 The precision and bias of this test method are based on data obtained from results from six laboratories using six replicate specimens, glass substrates, and a high-modulus sealant. Both applicator and oven methods were used and the mode of failure on all samples was cohesive.

13.2 *Applicator Method*—In the laboratory study using this method the within-laboratory coefficient of variation was found to be 9.11 % of the mean and the between-laboratory coefficient of variation was found to be 11.8 % of the mean.

13.2.1 *Repeatability*—Two results, each the mean of triplicate determinations, obtained by the same operator on different days, should be considered suspect if they differ by more than 14.6 % relative.

13.2.2 *Reproducibility*—Two results, each the mean of triplicate determinations, obtained by operators in different laboratories, should be considered suspect if they differ by more than 34.0 % relative.

<sup>4</sup> Supporting data have been filed at ASTM Headquarters. Request RR: C24-1041.