

INTERNATIONAL STANDARD

ISO
34-2

First edition
1996-12-15

Rubber, vulcanized or thermoplastic — Determination of tear strength —

Part 2:
Small (Delft) test pieces

iTeh STANDARD PREVIEW
(standards.iteh.ai)

[ISO 34-2:1996](https://standards.iteh.ai/catalog/standards/sist/ba9c3284-b140-45dc-8a11-94f6a412d345/iso-34-2-1996)

<https://standards.iteh.ai/catalog/standards/sist/ba9c3284-b140-45dc-8a11-94f6a412d345/iso-34-2-1996>

*Caoutchouc vulcanisé ou thermoplastique — Détermination de la
résistance au déchirement*

Partie 2: Petites éprouvettes (éprouvettes de Delft)



Reference number
ISO 34-2:1996(E)

Foreword

ISO (the International Organization for Standardization) is a worldwide federation of national standards bodies (ISO member bodies). The work of preparing International Standards is normally carried out through ISO technical committees. Each member body interested in a subject for which a technical committee has been established has the right to be represented on that committee. International organizations, governmental and non-governmental, in liaison with ISO, also take part in the work. ISO collaborates closely with the International Electrotechnical Commission (IEC) on all matters of electrotechnical standardization.

Draft International Standards adopted by the technical committees are circulated to the member bodies for voting. Publication as an International Standard requires approval by at least 75 % of the member bodies casting a vote.

International Standard ISO 34-2 was prepared by Technical Committee ISO/TC 45, *Rubber and rubber products*, Subcommittee SC 2, *Physical and degradation tests*.

It cancels and replaces International Standard ISO 816:1983, of which it constitutes a technical revision.

ISO 34 consists of the following parts, under the general title *Rubber, vulcanized or thermoplastic — Determination of tear strength*:

- Part 1: *Trouser, angle and crescent test pieces*
- Part 2: *Small (Delft) test pieces*

Annexes A, B and C of this part of ISO 34 are for information only.

© ISO 1996

All rights reserved. Unless otherwise specified, no part of this publication may be reproduced or utilized in any form or by any means, electronic or mechanical, including photocopying and microfilm, without permission in writing from the publisher.

International Organization for Standardization
Case Postale 56 • CH-1211 Genève 20 • Switzerland
Printed in Switzerland

Rubber, vulcanized or thermoplastic — Determination of tear strength —

Part 2: Small (Delft) test pieces

1 Scope

This part of ISO 34 specifies a method for the determination of the tear strength of small test pieces (Delft test pieces) of vulcanized or thermoplastic rubber.

NOTE — The method does not necessarily give results agreeing with those given by the method described in ISO 34-1. It is used in preference to ISO 34-1 when the available material is limited, and may be particularly suitable for testing small finished products.

(standards.iteh.ai)

2 Normative references

ISO 34-2:1996

<https://standards.iteh.ai/catalog/standards/sist/bacc3284-b140-45dc-8a11-94f6a412d345/iso-34-2-1996>

The following standards contain provisions which, through reference in this text, constitute provisions of this part of ISO 34. At the time of publication, the editions indicated were valid. All standards are subject to revision, and parties to agreements based on this part of ISO 34 are encouraged to investigate the possibility of applying the most recent editions of the standards indicated below. Members of IEC and ISO maintain registers of currently valid International Standards.

ISO 34-1:1994, *Rubber, vulcanized and thermoplastic — Determination of tear strength — Part 1: Trouser, angle and crescent test pieces.*

ISO 471:1995, *Rubber — Temperatures, humidities and times for conditioning and testing.*

ISO 3383:1985, *Rubber — General directions for achieving elevated or subnormal temperatures for test purposes.*

ISO 4648:1991, *Rubber, vulcanized or thermoplastic — Determination of dimensions of test pieces and products for test purposes.*

ISO 5893:1993, *Rubber and plastics test equipment — Tensile, flexural and compression types (constant rate of traverse) — Description.*

ISO/TR 9272:1986, *Rubber and rubber products — Determination of precision for test method standards.*

3 Principle

The force required to tear across the width of a small test piece containing a slit in the centre is measured. (The slit is made and the test piece cut out in a single cutting operation.)

4 Apparatus

4.1 Tensile-testing machine, complying with the requirements of ISO 5893, capable of measuring force with an accuracy corresponding to grade B as defined in ISO 5893, and with a rate of traverse of the moving grip of 500 mm/min \pm 50 mm/min.

The capacity of the test machine shall be such that the force required to tear the test piece will be not less than 15 % or more than 85 % of that capacity.

NOTE — Inertia (pendulum) type dynamometers tend to give results which differ because of frictional and inertial effects. An inertialess (for example electronic or optical transducer type) dynamometer gives results which are free from these effects and is therefore to be preferred.

4.2 Die, for cutting out the test piece. The construction of the die and the knife which cuts the slit are shown in figures 1 and 2.

4.3 Micrometer gauge, complying with the requirements of ISO 4648 and having a circular foot approximately 6 mm in diameter which exerts a pressure of 22 kPa \pm 5 kPa¹⁾.

4.4 Travelling microscope, giving at least $\times 10$ magnification, fitted with a graticule graduated at 0,01 mm intervals.

5 Test pieces

iTeh STANDARD PREVIEW
(standards.iteh.ai)

5.1 Shape and dimensions

The test pieces shall be rectangular and shall conform to the dimensions shown in figure 3.

The test pieces shall be cut from a sheet by punching with the die (4.2), using a single blow of a mallet or (preferably) a single stroke of a press. The rubber may be wetted with water or a soap solution, and shall be supported on a sheet of slightly yielding material (for example leather, rubber belting or cardboard) on a flat, rigid surface.

The tear strength is particularly susceptible to grain effects in vulcanized rubber. Normally, all test pieces are prepared with the grain at right angles to their length, but, in cases where grain effects are significant and are to be evaluated, two sets of test pieces shall be cut from the sheet, one at right angles to the grain and the other parallel to the grain.

The thickness d of the test pieces shall be 2,0 mm \pm 0,2 mm.

5.2 Measurement of dimensions

5.2.1 Measurement of thickness d

Measure the thickness of the test piece by method A1 of ISO 4648:1991. Take at least three gauge readings in the region of the slit. If an even number of readings is taken, use the average of the two median values as the result. If an odd number of readings is taken, use the median value. No reading shall deviate by more than 2 % from the value used. When the test results are to be used for comparative purposes, the thickness of any test piece shall not vary by more than 10 % from the mean thickness of all the test pieces.

1) 1 kPa = 1 kN/m²

Dimensions in millimetres

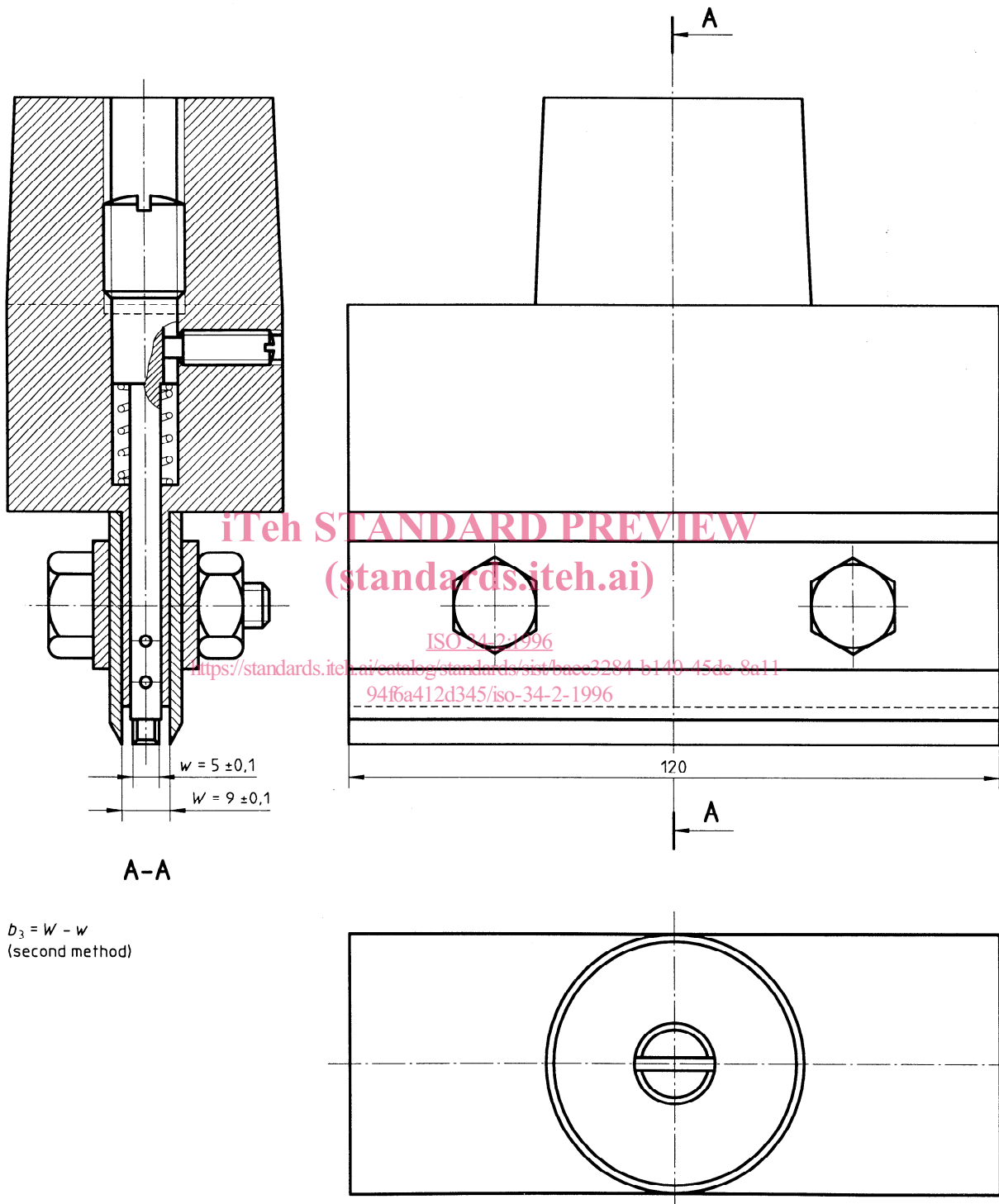

$D_3 = W - w$
(second method)

Figure 1 — Die for Delft test pieces

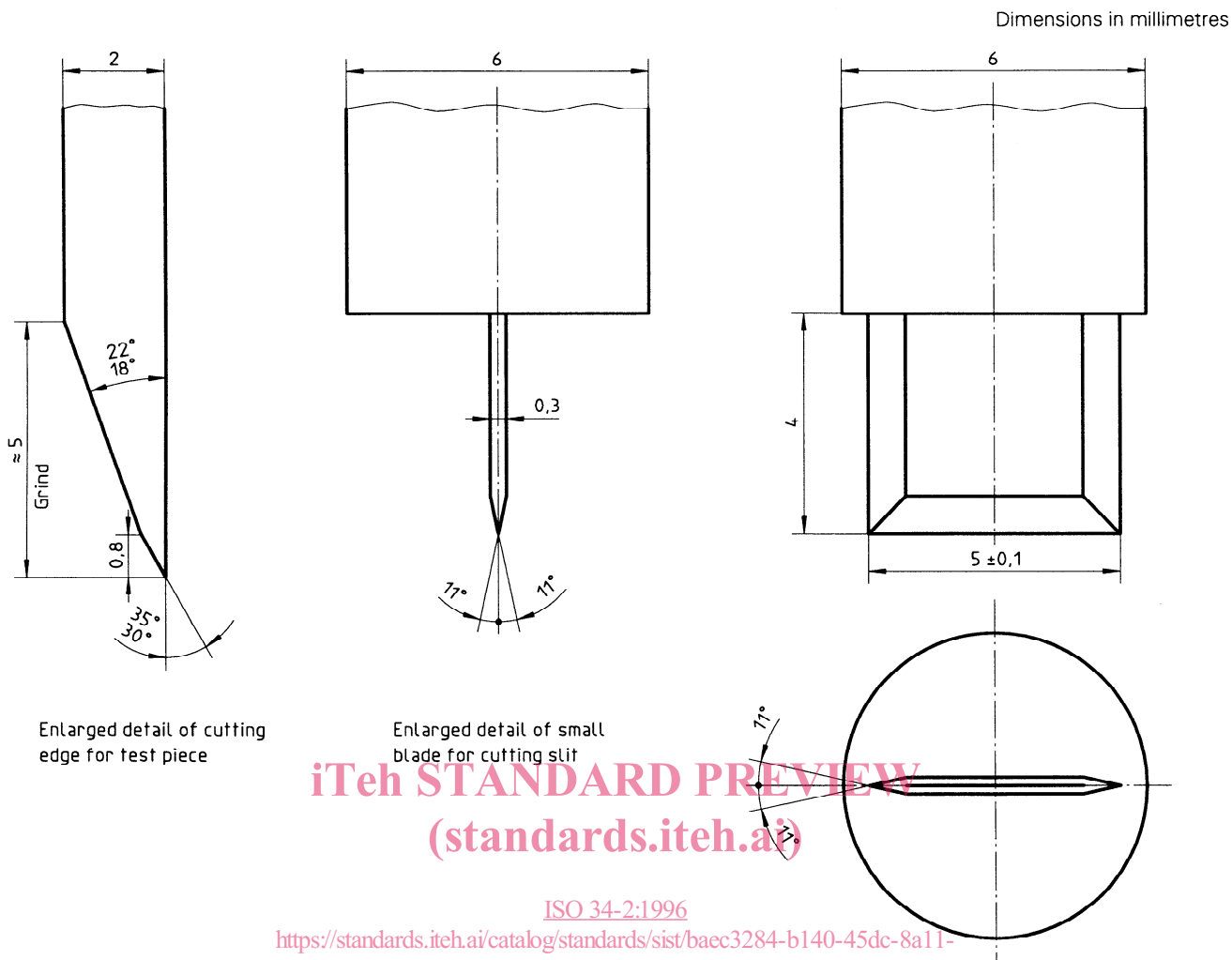
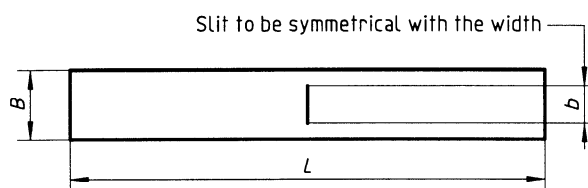

Figure 2 — Details of Delft test piece die cutting edges



Dimensions of test piece

| Dimension | mm |
|----------------------|-----------|
| <i>L</i> Length | 60 |
| <i>B</i> Width | 9,0 ± 0,1 |
| <i>b</i> Slit length | 5,0 ± 0,1 |

Figure 3 — Test piece

5.2.2 Measurement of the total width outside the slit

This total width outside the slit b_3 corresponds to the rubber to be torn.

Two methods of measurement can be used. The first method is theoretically more exact, but is difficult to use in practice. The second method, which is in common use, is simpler but can give different results.

Unless otherwise specified, use the second method.

Results obtained using test pieces measured by different methods shall not be compared.

5.2.2.1 First method: Measurement by travelling microscope

Variations occur in the length of the slit and in the total width of the test piece when the same die is used to prepare test pieces from rubber of different hardnesses. Moreover, the slit may not be uniform throughout its depth, but may be wider at one surface. Take one test piece which has been cut out with the die, therefore, and use it to measure the width to be torn by cutting the test piece through with a sharp razor blade in the plane of the slit and measuring the cut surfaces (width on either side of the slit) with a travelling microscope. The ends of the slit are curved as shown in figure 4, and an attempt shall be made to allow for this curvature when measuring the width on either side of the slit, as follows:

Take as the width on the left-hand side b_1 , which is the distance from the line AB to an imaginary line A'B' which is situated so that the total area $S_1 + S_2 = S_3$.

Similarly, on the right-hand side, imagine a line C'D' situated so that the total area $S'_1 + S'_2 = S'_3$ and b_2 is the width.

The total width b_3 outside the slit (i.e. the rubber to be torn) is then $b_1 + b_2$.

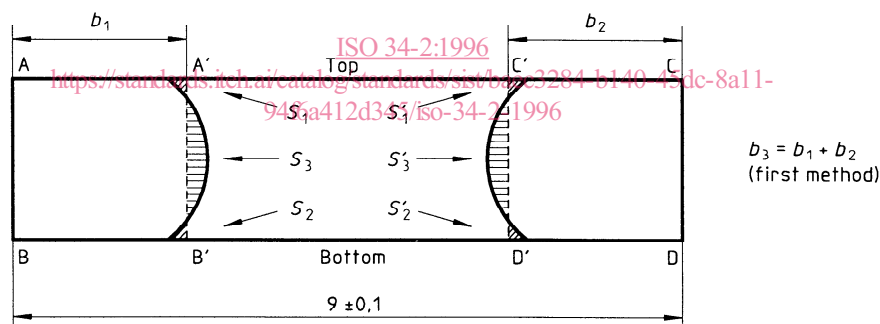

Figure 4 — Section through slit in Delft test piece

5.2.2.2 Second (simpler) method: Measurement from the dimensions of the die used to cut the test piece

Calculate b_3 from the dimensions of the die (see figure 1), using the following equation:

$$b_3 = W - w$$

where

W is the measured distance between the cutting edges of the die;

w is the measured width of the blade for cutting the slit.

5.3 Number

At least three and preferably six pieces shall be tested.

5.4 Time interval between vulcanization and testing

The time between vulcanization and testing shall be in accordance with ISO 471.

6 Temperature of test

The test is normally carried out at a standard laboratory temperature of $23\text{ °C} \pm 2\text{ °C}$ or $27\text{ °C} \pm 2\text{ °C}$, as specified in ISO 471.

If the test is to be carried out at a temperature other than a standard laboratory temperature, condition the test piece, immediately prior to testing, for a period sufficient to reach substantial temperature equilibrium at the test temperature. Keep this period as short as possible in order to avoid ageing the rubber (see ISO 3383).

Use the same temperature throughout any one test, as well as any series of tests intended to be comparable.

7 Procedure

Mount the test piece in the testing machine so that the free length between the points of contact of the grips on the test piece is 30 mm, i.e. so that each grip is 15 mm from the slit. Stretch the test piece in the machine. Do not interrupt the stretching before the test piece has torn completely through. Note the maximum force reached during tearing.

iTeh STANDARD PREVIEW (standards.iteh.ai)

8 Expression of results

The tearing force depends on the thickness of the test piece and the width of the rubber torn, and the result is therefore expressed as the force necessary to tear a test piece of standard width and thickness. This value, the tear strength F_0 , in newtons, is given by the equation

$$F_0 = \frac{8F}{b_3 d}$$

where

- 8 is the product of the nominal values of b_3 (4 mm) and d (2 mm);
- F is the force, in newtons, required to tear the test piece;
- b_3 is the actual width, in millimetres, of the rubber torn in the test piece (see 5.2);
- d is the actual thickness, in millimetres, of the test piece.

Arrange the results in order of increasing value and take as the result the average of the two median values if the number of test pieces is even, or the median value if the number of test pieces is odd. If only three test pieces are tested, give the individual results.

9 Precision

9.1 General

The calculations to determine the repeatability and reproducibility were performed in accordance with ISO/TR 9272. Consult this for precision concepts and nomenclature. Annex A gives guidance on the use of repeatability and reproducibility results.

9.2 Precision details

9.2.1 An interlaboratory test programme (ITP) was organized in 1989 by the Laboratoire de Recherches et de Contrôle du Caoutchouc et des Plastiques (LRCCP).

Test pieces prepared by LRCCP from cured sheets of three compounds A, B and C (the same as were used for the ITP for ISO 34-1) were sent out to all participating laboratories. Details of these compounds are outlined in annex B. In each laboratory, the following operations were carried out on each of the two testing days a week apart: thickness measurement, measurement of the total width outside the slit (methods 1 and 2) and, finally, tear strength measurement.

For each set of measurements, two types of test piece were used:

- direction 1 test pieces, cut with the mill grain at 90° to the direction of elongation;
- direction 2 test pieces, cut with the mill grain parallel to the direction of elongation.

Five laboratories participated in the testing of test pieces whose width outside the slit was measured using method 1, seven in the testing of test pieces whose width outside the slit was measured using method 2.

9.2.2 The precision determined is a type 1 precision; no mixing or curing of the test compounds was done in the participating laboratories.

9.3 Precision results

The precision results for all tests are given in table 1. See annex A for guidance on using precision results. For comments see annex C.

(standards.iteh.ai)

The symbols used in table 1 are as follows:

- r = repeatability, measurement units
- (r) = repeatability, as percentage of material average
- R = reproducibility, measurement units
- (R) = reproducibility, as percentage of material average

Pooled (r) and (R) values are calculated on the basis of pooled r and R and overall material average values.

10 Test report

The test report shall include the following particulars:

- a) a reference to this part of ISO 34;
- b) all details necessary for identification of the sample tested;
- c) the method of measurement of the total width outside the slit;
- d) the tear strength, calculated in accordance with clause 8;
- e) the temperature of test;
- f) the direction of the grain in the test piece;
- g) the date of vulcanization, if known, and the date of testing.