**Aerospace — Airframe needle roller
bearings, single-row, shielded — Inch
series**

*Aéronautique et espace — Roulements à aiguilles, à une rangée, avec
flasques, pour cellule d'aéronef — Série «inch»*

iTeh STANDARD PREVIEW
(standards.iteh.ai)

[ISO 13414:1997](https://standards.iteh.ai/catalog/standards/sist/99537bff-9cb5-4236-a496-2c741010d090/iso-13414-1997)

[https://standards.iteh.ai/catalog/standards/sist/99537bff-9cb5-4236-a496-
2c741010d090/iso-13414-1997](https://standards.iteh.ai/catalog/standards/sist/99537bff-9cb5-4236-a496-2c741010d090/iso-13414-1997)



Foreword

ISO (the International Organization for Standardization) is a worldwide federation of national standards bodies (ISO member bodies). The work of preparing International Standards is normally carried out through ISO technical committees. Each member body interested in a subject for which a technical committee has been established has the right to be represented on that committee. International organizations, governmental and non-governmental, in liaison with ISO, also take part in the work. ISO collaborates closely with the International Electrotechnical Commission (IEC) on all matters of electrotechnical standardization.

Draft International Standards adopted by the technical committees are circulated to the member bodies for voting. Publication as an International Standard requires approval by at least 75 % of the member bodies casting a vote.

International Standard ISO 13414 was prepared by Technical Committee ISO/TC 20, *Aircraft and space vehicles*, Subcommittee SC 15, *Airframe bearings*.

Annex A of this International Standard is for information only.

iTeh STANDARD PREVIEW (standards.iteh.ai)

ISO 13414:1997

<https://standards.iteh.ai/catalog/standards/sist/99537bff-9cb5-4236-a496-2c741010d090/iso-13414-1997>

© ISO 1997

All rights reserved. Unless otherwise specified, no part of this publication may be reproduced or utilized in any form or by any means, electronic or mechanical, including photocopying and microfilm, without permission in writing from the publisher.

International Organization for Standardization
Case postale 56 • CH-1211 Genève 20 • Switzerland
Internet central@iso.ch
X.400 c=ch; a=400net; p=iso; o=isocs; s=central

Printed in Switzerland

Introduction

At the time this International Standard was developed, the Imperial units sizes of airframe needle roller bearings were dominant in world application. The basis for this International Standard is the imperial units provided in annex A.

iTeh STANDARD PREVIEW (standards.iteh.ai)

ISO 13414:1997

<https://standards.iteh.ai/catalog/standards/sist/99537bff-9cb5-4236-a496-2c741010d090/iso-13414-1997>

iTeh STANDARD PREVIEW
(standards.iteh.ai)

ISO 13414:1997

<https://standards.iteh.ai/catalog/standards/sist/99537bff-9cb5-4236-a496-2c741010d090/iso-13414-1997>

Aerospace — Airframe needle roller bearings, single-row, shielded— Inch series

1 Scope

This International Standard specifies the characteristics, boundary dimensions, tolerances, internal clearances and permissible static radial loads of inch series, single-row, needle roller bearings used in airframe applications.

The airframe needle roller bearings covered by this International Standard are designed to operate in the temperature range -54 °C to $+121\text{ °C}$.

2 Normative references

The following standards contain provisions which, through reference in this text, constitute provisions of this International Standard. At the time of publication, the editions indicated were valid. All standards are subject to revision, and parties to agreements based on this International Standard are encouraged to investigate the possibility of applying the most recent editions of the standards indicated below. Members of IEC and ISO maintain registers of currently valid International Standards.

ISO 683-17:—¹⁾, *Heat-treated steels, alloy steels and free-cutting steels — Part 17: Ball and roller bearing steels.*

ISO 1132:1980, *Rolling bearings — Tolerances — Definitions.*

ISO 2082:1986, *Metallic coatings — Electroplated coatings of cadmium on iron or steel.*

ISO 4520:1981, *Chromate conversion coatings on electroplated zinc and cadmium coatings.*

ISO 5593:1997, *Rolling bearings — Vocabulary.*

ISO 6158:1984, *Metallic coatings — Electroplated coatings of chromium for engineering purposes.*

ISO 13411:1997, *Aerospace — Airframe needle roller, cylindrical roller and track roller bearings — Technical specification.*

AMS 2417E:1993, *Plating, zinc-nickel alloy.*²⁾

3 Definitions

For the purposes of this International Standard, the definitions given in ISO 5593 apply.

4 Symbols

4.1 For the purposes of this International Standard, the symbols given in ISO 1132 apply. The symbols (except those for tolerances) shown in the figures and the values given in the tables denote nominal dimensions unless specified otherwise.

¹⁾ To be published. (Revision of ISO 683-17:1976)

²⁾ Available from: SAE International
400 Commonwealth Drive
Warrendale, PA 15096-0001
USA

4.2 The following additional symbols for bearings covered by this International Standard also apply.

B overall width (over faces of end washers)

C_s permissible static radial load

d_a clamping face diameter

5 Required characteristics

5.1 Dimensions — Tolerances — Internal clearances — Loads

For values, see table 1. For configuration, see figure 1.

Table 1

Dimensions in millimetres,
tolerance and clearance values in micrometres

Diameter code	d	D	B 0 - 127	C 0 - 127	Tolerance values			r_s min.	d_a min.	Internal clearance			C_s kN	Mass kg ≈				
					Δ_{dmp}	K_{ia} max.	Δ_{Dmp}			Radial, G_r		Axial, G_a						
									min.	max.	max.							
03	4,826	17,463	7,93	5,54	0 - 18	25	0,55	0,81	8	43	635	8	0,01					
05	6,35	19,05	9,53	7,14								12,7	0,02					
05	7,938	20,638	11,1	8,74					18,1	0,03								
06	9,525	22,225	14,28	11,92					28,1	0,03								
07	11,113	23,813	15,88	13,49					35,5	0,04								
08	12,7	28,575	19,05	16,67					51,5	0,08								
09	14,288	30,163	22,23	19,84					66,7	0,09								
10	15,875	31,75	25,4	23,02					84	0,11								
12	19,05	34,925	28,58	25,4					106,3	0,15								
14	22,225	41,275	31,75	28,58					0 - 15	0,81		0,81	15	56	635	135,6	0,19	
16	25,4	44,45			150,7	0,23												
20	31,75	50,8			168,5	0,27												
24	38,1	57,15			196,6	0,32												
28	44,45	63,5			224,6	0,35												
32	50,8	69,85			252,6	0,4												
36	57,15	76,2			280,6	0,44												
40	63,5	82,55			308,6	0,48												
44	69,85	88,9			336,7	0,52												
48	76,2	95,25			364,7	0,56												
52	82,55	101,6	26,65	0 - 20	0,81	1,11	1,11	46	104	635	392,7	0,61						
56	88,9	111,125									430,1	0,8						
60	95,25	117,475						458,1	0,84									
64	101,6	123,825						484,8	0,91									
80	127	149,225						600,4	1,25									
								26,52	0/- 25					53	114			

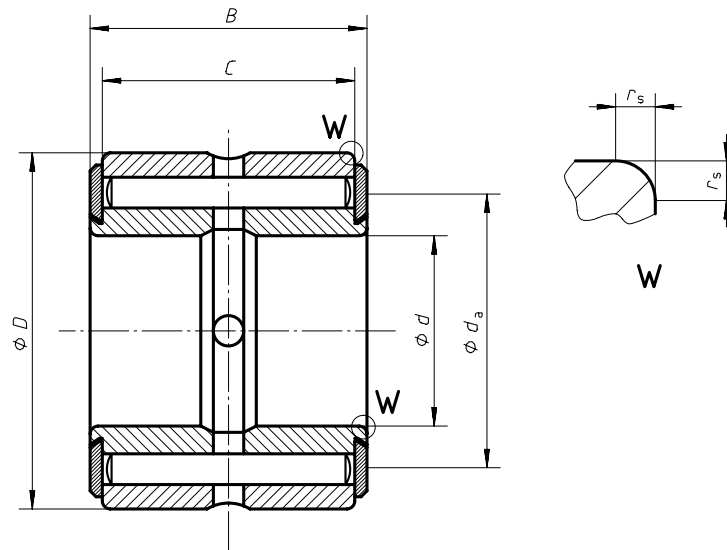

Figure 1

5.2 Surface roughness

Rollers: $R_a = 0,2 \mu\text{m}$ max.

Inner ring raceway: $R_a = 0,4 \mu\text{m}$ max.

Outer ring raceway: $R_a = 1,0 \mu\text{m}$ max.

End washers: $R_a = 1,6 \mu\text{m}$ max. at roller contact area.

ISO 13414:1997

<http://standards.iteh.ai/catalog/standards/sist/99537bff-9cb5-4236-a496-2c741010d090/iso-13414-1997>

6 Materials

Rings: bearing steel - ISO 683-17, type 1, raceway hardness 58 HRC to 66 HRC (670 HV to 860 HV).

Rollers: bearing steel - ISO 683-17, type 1, heat treated to 58 HRC to 66 HRC (670 HV to 860 HV).

End washers: steel heat treated to 51 HRC to 60 HRC (528 HV to 697 HV) at roller contact area.

7 Surface treatment

7.1 All external surfaces, except the inner ring bore surface, shall be cadmium or zinc-nickel plated.

7.2 Where cadmium plating is specified (code letters D and M), it shall be in accordance with ISO 2082. The thickness of the plating shall not be less than $7 \mu\text{m}$ and not more than $15 \mu\text{m}$. The bearing shall be embrittlement-relieved within 4 h of plating by heat treatment at $140 \text{ }^\circ\text{C} \pm 10 \text{ }^\circ\text{C}$ for a minimum of 8 h followed by chromate treatment in accordance with ISO 4520 (code letter D only).

7.3 Where zinc-nickel plating is specified (code letter Z), it shall be in accordance with AMS 2417E, type 2. The thickness of the plating shall not be less than $7 \mu\text{m}$ and not more than $15 \mu\text{m}$.

8 Lubrication

8.1 The bearing shall be prelubricated with either grease A or B as specified by the customer.

NOTE — Descriptions of grease A and grease B are given in ISO 13411:1997, annex I.

9 Designation

Bearings covered by this International Standard shall be designated only as in the following example:

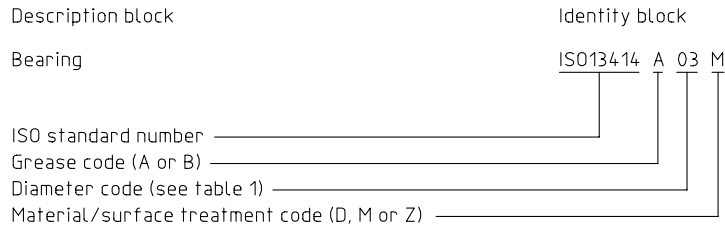

where the following codes are applied:

— greases:

A = ester type grease;

B = synthetic hydrocarbon type grease;

— materials/surface treatments:

D = material: low alloy bearing steel;

- surface treatment: outer ring - cadmium plated with chromate conversion coating;
- washer - cadmium plated with chromate conversion coating;
- inner ring - cadmium plated with chromate conversion coating;

M = material: low alloy bearing steel;

- surface treatment: outer ring - cadmium plated without chromate conversion coating;
- washer - cadmium plate without chromate conversion coating;
- inner ring - cadmium plated without chromate conversion coating;

Z = material: low alloy bearing steel;

- surface treatment: outer ring - zinc-nickel plated;
- washer - zinc-nickel plated;
- inner ring - zinc-nickel plated.

10 Identification marking

In addition to the manufacturer's name or trademark, each bearing shall be permanently and legibly marked, using the identity block as defined in clause 9. Marking position and method shall be at the manufacturer's option.

11 Technical specification

Airframe needle roller bearings supplied to this International Standard shall conform to the requirements of ISO 13411.

Annex A (informative)

Imperial (non-SI) units

Table A.1 gives the imperial (non-SI) unit information that is the basis for this International Standard.

Table A.1

Dimensions in inches,
tolerance and clearance values in 0,000 1 in

Diameter code	d	D	B 0 - 50	C 0 - 50	Tolerance values			r_s min.	d_a min.	Internal clearance			C_s lbf	Mass lb ≈
					Δ_{dmp}	K_{ia} max.	Δ_{Dmp}			Radial, G_r		Axial, G_a max.		
										min.	max.			
03	0,19	0,687 5	0,312	0,218	10	0	-5	0,022	0,438	3	17	250	1 800	0,03
04	0,25	0,75	0,375	0,281					0,516				2 870	0,04
05	0,312 5	0,812 5	0,437	0,344					0,578				4 870	0,06
06	0,375	0,875	0,562	0,469					0,641	4	18		6 330	0,08
07	0,437 5	0,937 5	0,625	0,531					0,703				8 000	0,1
08	0,5	1,125	0,75	0,656					0,844	5	19		11 600	0,16
09	0,562 5	1,187 5	0,875	0,781					0,891				15 000	0,21
10	0,625	1,25	1	0,906					0,953	6	22		18 900	0,25
12	0,75	1,375	1,125	1					1,078				23 900	0,34
14	0,875	1,625	1,25	1,049					0	-8	0,032		1,25	10
16	1	1,75			1,375	33 900	0,51							
20	1,25	2			1,625	37 900	0,6							
24	1,5	2,25			1,875	44 200	0,71							
28	1,75	2,5			2,125	50 500	0,78							
32	2	2,75			2,375	56 800	0,88							
36	2,25	3			2,625	63 100	0,98							
40	2,5	3,25			2,875	69 400	1,06							
44	2,75	3,5			3,125	75 700	1,15							
48	3	3,75			3,375	82 000	1,24							
52	3,25	4	3,641	88 300	1,34									
56	3,5	4,375	0	-8	0,044	18	41	3,969	21	45	96 700	1,73		
60	3,75	4,625						4,218			103 000	1,84		
64	4	4,875	0	-10	0,044	21	45	4,469	21	45	109 000	1,99		
80	5	5,875						1,044			0/-10	5,438	135 000	2,75