

INTERNATIONAL  
STANDARD

**ISO**  
**8489-5**

First edition  
1995-12-15

---

---

**Textile machinery and accessories —  
Cones for cross winding —**

**Part 5:**

Dimensions, tolerances and designation  
of cones with half angle 5° 57'

**Document Preview**

*Matériel pour l'industrie textile — Cônes pour bobinage croisé —*

*Partie 5: Dimensions, tolérances et désignation des cônes avec  
demi-angle au sommet de 5° 57'*

<https://standards.itech.ai/catalog/standards/iso/da80c4f1-c48b-47e9-acb0-f4dfdd4ffb58/iso-8489-5-1995>



Reference number  
ISO 8489-5:1995(E)

## Foreword

ISO (the International Organization for Standardization) is a worldwide federation of national standards bodies (ISO member bodies). The work of preparing International Standards is normally carried out through ISO technical committees. Each member body interested in a subject for which a technical committee has been established has the right to be represented on that committee. International organizations, governmental and non-governmental, in liaison with ISO, also take part in the work. ISO collaborates closely with the International Electrotechnical Commission (IEC) on all matters of electrotechnical standardization.

Draft International Standards adopted by the technical committees are circulated to the member bodies for voting. Publication as an International Standard requires approval by at least 75 % of the member bodies casting a vote.

International Standard ISO 8489-5 was prepared by Technical Committee ISO/TC 72, *Textile machinery and allied machinery and accessories*, Subcommittee SC 2, *Winding and preparatory machinery for fabric manufacture*.

This first edition of ISO 8489-5 cancels and replaces ISO 5237:1978, which has been technically revised.

ISO 8489 consists of the following parts, under the general title *Textile machinery and accessories — Cones for cross winding*:

- *Part 1: Recommended main dimensions*
- *Part 2: Dimensions, tolerances and designation of cones with half angle 3 degrees 30'*
- *Part 3: Dimensions, tolerances and designation of cones with half angle 4 degrees 20'*
- *Part 4: Dimensions, tolerances and designation of cones with half angle 4 degrees 20' for winding for dyeing purposes*
- *Part 5: Dimensions, tolerances and designation of cones with half angle 5 degrees 57'*

© ISO 1995

All rights reserved. Unless otherwise specified, no part of this publication may be reproduced or utilized in any form or by any means, electronic or mechanical, including photocopying and microfilm, without permission in writing from the publisher.

International Organization for Standardization  
Case Postale 56 • CH-1211 Genève 20 • Switzerland

Printed in Switzerland

# Textile machinery and accessories — Cones for cross winding —

## Part 5:

Dimensions, tolerances and designation of cones with half angle  $5^{\circ} 57'$

iTeh Standards  
(<https://standards.iteh.ai>)

### 1 Scope

This part of ISO 8489 specifies the main dimensions, tolerances and designation of cones for cross winding with a half angle of cone  $5^{\circ} 57'$ . Furthermore, directives are given for the characteristics of cones and for the control of the diameters and lengths of the cone.

[ISO 8489-5:1995](#)

<https://standards.iteh.ai/catalog/standards/iso/da80c4f1-c48b-47e9-aeb0-f4dfdd4ffb58/iso-8489-5-1995>

### 2 Normative references

The following standards contain provisions which, through reference in this text, constitute provisions of this part of ISO 8489. At the time of publication, the editions indicated were valid. All standards are subject to revision, and parties to agreements based on this part of ISO 8489 are encouraged to investigate the possibility of applying the most recent editions of the standards indicated below. Members of IEC and ISO maintain registers of currently valid International Standards.

ISO 286-1:1988, *ISO system of limits and fits — Part 1: Bases of tolerances, deviations and fits.*

ISO 8489-1:1995, *Textile machinery and accessories — Cones for cross winding — Part 1: Recommended main dimensions.*

### 3 Dimensions and tolerances

See figure 1 a) and b) and table 1.

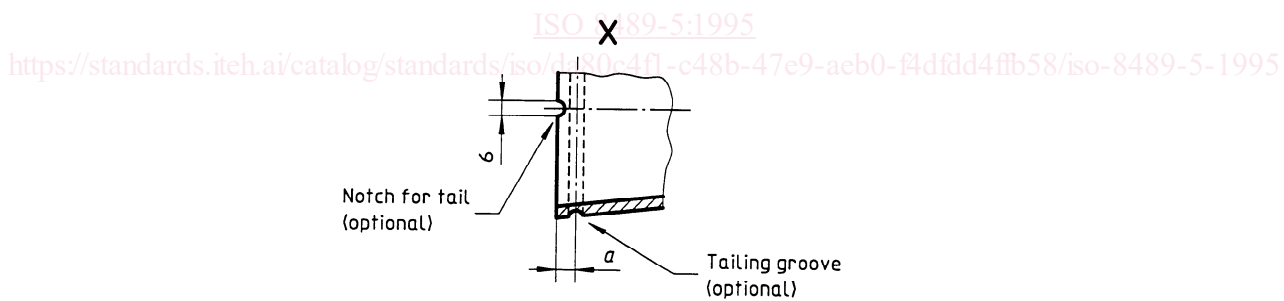
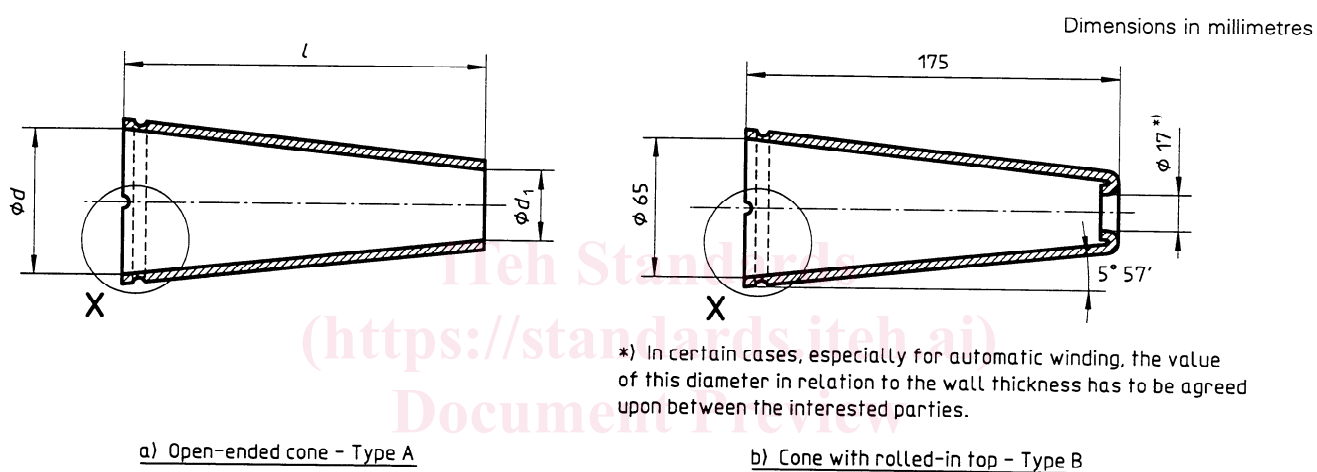

**Figure 1 — Cones**