

Second edition
2000-12-15

Corrected version
2003-08-01

**Flexible cellular polymeric materials —
Laboratory assessment of horizontal
burning characteristics of small specimens
subjected to a small flame**

*Matières alvéolaires polymères souples — Méthode de laboratoire pour la
détermination des caractéristiques de combustion de petites éprouvettes
soumises, en position horizontale, à une petite flamme*

iTeh STANDARD PREVIEW
(standards.iteh.ai)

[ISO 3582:2000](https://standards.iteh.ai/catalog/standards/sist/d166c3ee-6f82-4613-b810-7274c02b9f17/iso-3582-2000)

<https://standards.iteh.ai/catalog/standards/sist/d166c3ee-6f82-4613-b810-7274c02b9f17/iso-3582-2000>



Reference number
ISO 3582:2000(E)

© ISO 2000

PDF disclaimer

This PDF file may contain embedded typefaces. In accordance with Adobe's licensing policy, this file may be printed or viewed but shall not be edited unless the typefaces which are embedded are licensed to and installed on the computer performing the editing. In downloading this file, parties accept therein the responsibility of not infringing Adobe's licensing policy. The ISO Central Secretariat accepts no liability in this area.

Adobe is a trademark of Adobe Systems Incorporated.

Details of the software products used to create this PDF file can be found in the General Info relative to the file; the PDF-creation parameters were optimized for printing. Every care has been taken to ensure that the file is suitable for use by ISO member bodies. In the unlikely event that a problem relating to it is found, please inform the Central Secretariat at the address given below.

iTeh STANDARD PREVIEW
(standards.iteh.ai)

ISO 3582:2000

<https://standards.iteh.ai/catalog/standards/sist/d166c3ee-6f82-4613-b810-7274c02b9f17/iso-3582-2000>

© ISO 2000

All rights reserved. Unless otherwise specified, no part of this publication may be reproduced or utilized in any form or by any means, electronic or mechanical, including photocopying and microfilm, without permission in writing from either ISO at the address below or ISO's member body in the country of the requester.

ISO copyright office
Case postale 56 • CH-1211 Geneva 20
Tel. + 41 22 749 01 11
Fax + 41 22 749 09 47
E-mail copyright@iso.org
Web www.iso.org

Published in Switzerland

Contents

	Page
1	Scope..... 1
2	Normative reference..... 1
3	Significance of test 1
4	General 2
5	Apparatus..... 2
6	Number, size, marking and weighing of test pieces..... 6
7	Conditioning of test pieces 6
8	Test procedure 7
9	Calculations 8
10	Test report..... 9

iTeh STANDARD PREVIEW
(standards.iteh.ai)

[ISO 3582:2000](https://standards.iteh.ai/catalog/standards/sist/d166c3ee-6f82-4613-b810-7274c02b9f17/iso-3582-2000)

<https://standards.iteh.ai/catalog/standards/sist/d166c3ee-6f82-4613-b810-7274c02b9f17/iso-3582-2000>

Foreword

ISO (the International Organization for Standardization) is a worldwide federation of national standards bodies (ISO member bodies). The work of preparing International Standards is normally carried out through ISO technical committees. Each member body interested in a subject for which a technical committee has been established has the right to be represented on that committee. International organizations, governmental and non-governmental, in liaison with ISO, also take part in the work. ISO collaborates closely with the International Electrotechnical Commission (IEC) on all matters of electrotechnical standardization.

International Standards are drafted in accordance with the rules given in the ISO/IEC Directives, Part 3.

Draft International Standards adopted by the technical committees are circulated to the member bodies for voting. Publication as an International Standard requires approval by at least 75 % of the member bodies casting a vote.

Attention is drawn to the possibility that some of the elements of this International Standard may be the subject of patent rights. ISO shall not be held responsible for identifying any or all such patent rights.

International Standard ISO 3582 was prepared by Technical Committee ISO/TC 45, *Rubber and rubber products*, Subcommittee SC 4, *Products (other than hoses)*.

This second edition cancels and replaces the first edition (ISO 3582:1978), which has been technically revised.

In this corrected version of ISO 3582:2000, Figure 1 has been amended so that the arrow indicating the dimension 380 ± 10 on the left-hand side of the figure extends only to the top of the door, not to the top of the cabinet.

[ISO 3582:2000](https://standards.iteh.ai/catalog/standards/sist/d166c3ee-6f82-4613-b810-7274c02b9f17/iso-3582-2000)

<https://standards.iteh.ai/catalog/standards/sist/d166c3ee-6f82-4613-b810-7274c02b9f17/iso-3582-2000>

Flexible cellular polymeric materials — Laboratory assessment of horizontal burning characteristics of small specimens subjected to a small flame

WARNING — Persons using this International Standard should be familiar with normal laboratory practice. This standard does not purport to address all of the safety problems, if any, associated with its use. It is the responsibility of the user to establish appropriate safety and health practices and to ensure compliance with any national regulatory conditions.

1 Scope

This International Standard specifies a small-scale laboratory screening procedure for comparing the relative horizontal burning characteristics of small test pieces of flexible cellular polymeric material exposed to a low-energy source of heat. It is intended only for the purpose of assessing quickly and simply the horizontal burning characteristics of small test pieces of the material as such, i.e. considered without reference to the environmental conditions under which the material, or products made from it, may be used. As a consequence, it is not possible to establish a correlation between the results of this test and the performance of such materials or products under actual service conditions. The test is restricted to test pieces of thickness greater than 5 mm. Results of tests on test pieces of different thicknesses are not comparable.

This test method is not intended to be used to assess the potential fire hazard in use.

NOTE For cellular plastics having a density less than 250 kg/m^3 , another test method exists: ISO 9772:2001, *Cellular plastics — Determination of horizontal burning characteristics of small specimens subjected to a small flame*. The test equipment and procedures differ from those contained in this International Standard, and it should not therefore be assumed that they will produce identical test results.

2 Normative reference

The following normative document contains provisions which, through reference in this text, constitute provisions of this International Standard. For dated references, subsequent amendments to, or revisions of, any of these publications do not apply. However, parties to agreements based on this International Standard are encouraged to investigate the possibility of applying the most recent edition of the normative document indicated below. For undated references, the latest edition of the normative document referred to applies. Members of ISO and IEC maintain registers of currently valid International Standards.

ISO 1923:1981, *Cellular plastics and rubbers — Determination of linear dimensions*.

3 Significance of test

Tests made on a material under the conditions specified here can be of considerable value in comparing the horizontal burning characteristics of different materials, in controlling manufacturing processes or in assessing any change in horizontal burning characteristics prior to, or during, use. Correlation with performance under actual service conditions is not implied, and the finished product should be tested in the form in which it will finally be used by a test method appropriate to products fulfilling a similar purpose.

It is essential to appreciate that this method of test is not intended, and cannot be used, to assess the potential fire hazard of a material or product in use. Assessment of fire hazard would require consideration of factors such as fuel contribution, intensity of burning and products of combustion, as well as environmental factors such as intensity of source, orientation of exposed material and ventilation conditions.

4 General

4.1 Horizontal burning characteristics, as measured by this test procedure, are affected by factors such as density, any anisotropy of the cellular material and the thickness of the test piece.

Certain materials may shrink from the applied flame without igniting. In this event, the test results are not valid and additional test pieces may be required to obtain the ten sets of data necessary. If the test pieces continue to shrink from the applied flame without igniting, the material is not suitable for evaluation by this method of test.

4.2 Inter-laboratory trials have shown that many variables influence the reproducibility of the results of this type of test. For this reason, the procedure laid down shall be adhered to in all respects, especially as regards the use and construction of the test chamber.

4.3 For certain materials which exhibit burning only along the upper surface of the test piece, the mass loss shall be measured and reported, if required.

4.4 The horizontal burning characteristics of some flexible cellular polymeric materials may change with time. It is accordingly advisable to make tests before and after ageing by an appropriate procedure, details of which shall be given in the test report.

iTeh STANDARD PREVIEW
(standards.iteh.ai)

5 Apparatus

5.1 **Test chamber**, constructed of non-combustible materials, for example insulating board on a steel frame, having inside dimensions of 600 mm \pm 5 mm in length, 300 mm \pm 5 mm in width and 760 mm \pm 5 mm in height, and being otherwise as shown in Figure 1. To allow easy access between tests, the chamber may be designed so that the front panel containing the window is removable, but, if so constructed, provision shall be made for ensuring that a draught-proof seal is obtained when the panel is in position. The chamber shall be used in a fume cupboard.

The chamber shall be draught-free, yet permit normal thermal circulation of air past the test piece during burning.

5.2 **Burner**, of internal diameter 9,5 mm \pm 0,5 mm. A gaseous hydrocarbon fuel shall be used to provide the standard flame shown in Figure 2. This flame shall maintain a temperature of 1 000 °C \pm 100 °C at a height of 13 mm \pm 1 mm above the burner top.

NOTE Propane, of at least 93 % purity, supplied through a jet of diameter 0,3 mm \pm 0,1 mm, is suitable for provision of the specified flame and temperature. This jet size is such that the propane pressure required to obtain the standard flame is less than 7 kPa.

5.3 **Wing top**, having an opening of internal length 48 mm \pm 1 mm and internal width 3,0 mm \pm 0,2 mm, fitted to the burner.

5.4 **Support gauze**, 215 mm long, 75 mm wide and having 13 mm of its length bent to form a right angle as shown in Figure 3. It shall consist of 6,4 mm mesh gauze constructed from 0,8 mm diameter stainless-steel wire. A minimum of four supports shall be available.

Dimensions in millimetres
(the dimensions shown are internal)

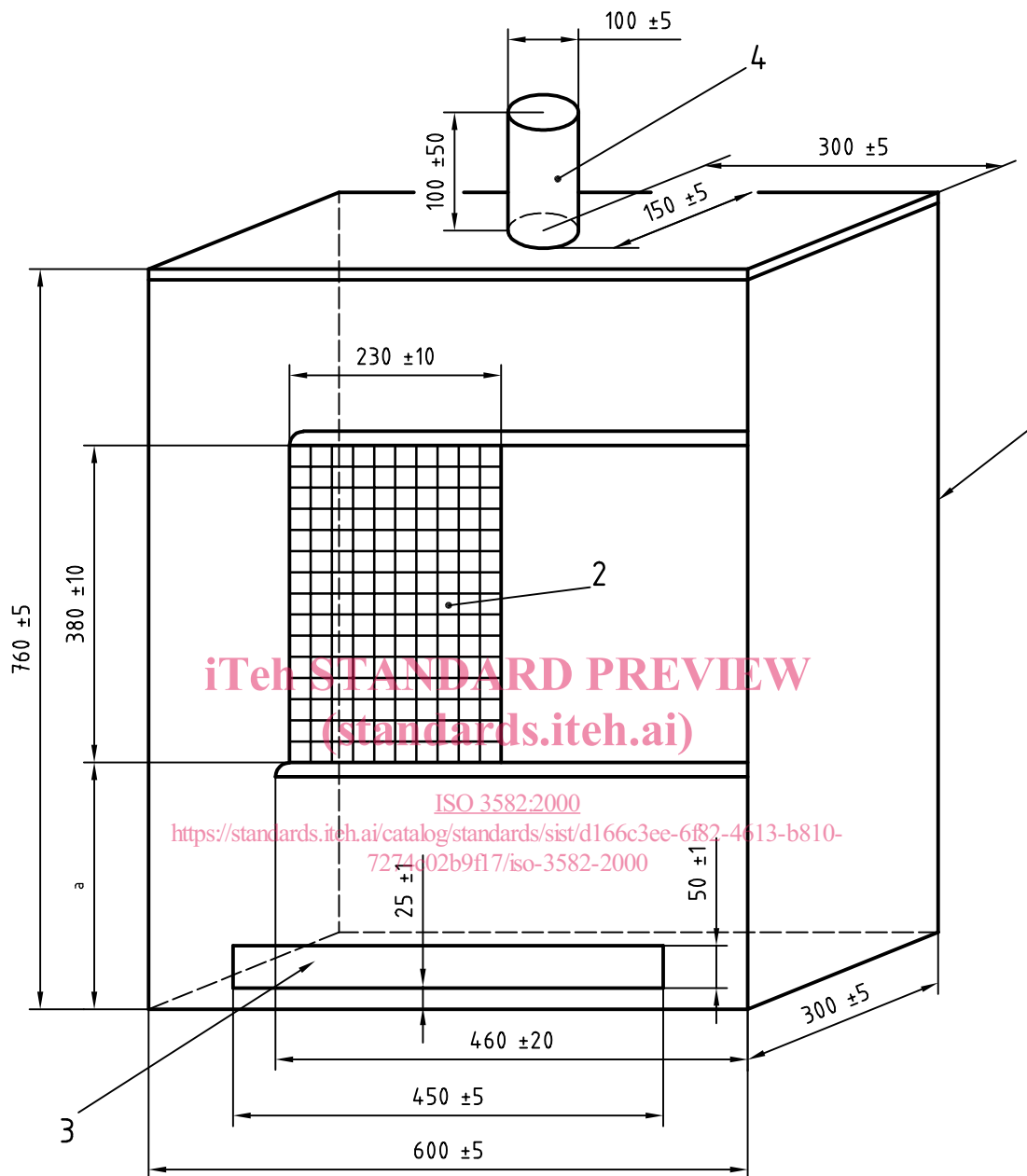

Key

- 1 Cabinet made from non-combustible material with draught-proof seal on lid and front panel
- 2 Toughened-glass sliding door with draught-proof seal
- 3 Ventilation slit
- 4 Ventilation chimney

^a It is recommended that the bottom of the window is approximately 25 mm below the normal position of the gauze during the test (see Figure 4)

Figure 1 — Test chamber

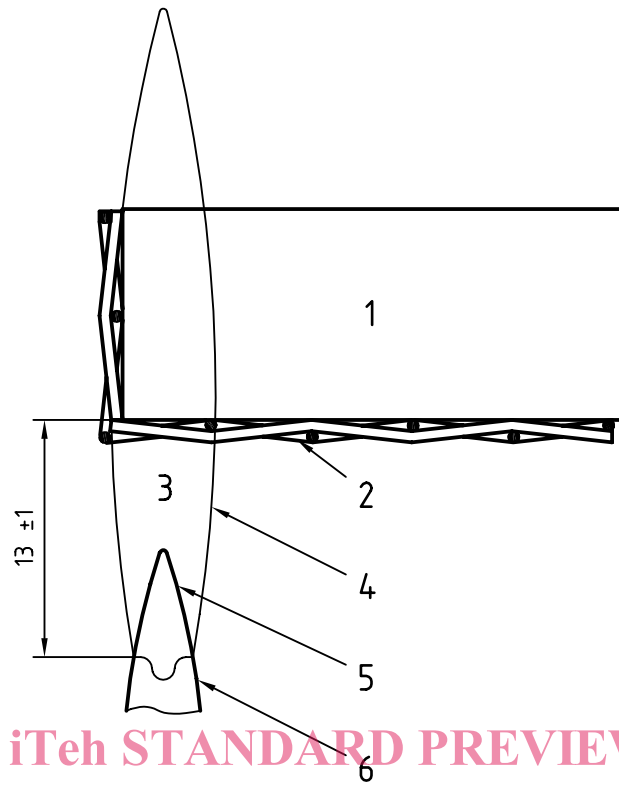

iTeh STANDARD PREVIEW
(standards.iteh.ai)

Key

- 1 Test piece, 13 mm thick
- 2 Test piece support gauze, 6,4 mm mesh
- 3 Blue flame
- 4 Profile of visible flame, 38 mm high
- 5 Profile of inner cone, 6 mm high
- 6 Burner wing top

ISO 3582:2000

standards.iteh.ai/catalog/standards/sist/d166c3ee-6f82-4613-b810-7274c02b9f17/iso-3582-2000

Figure 2 — Details of flame and relative positions of burner wing top, test piece and test piece support gauze

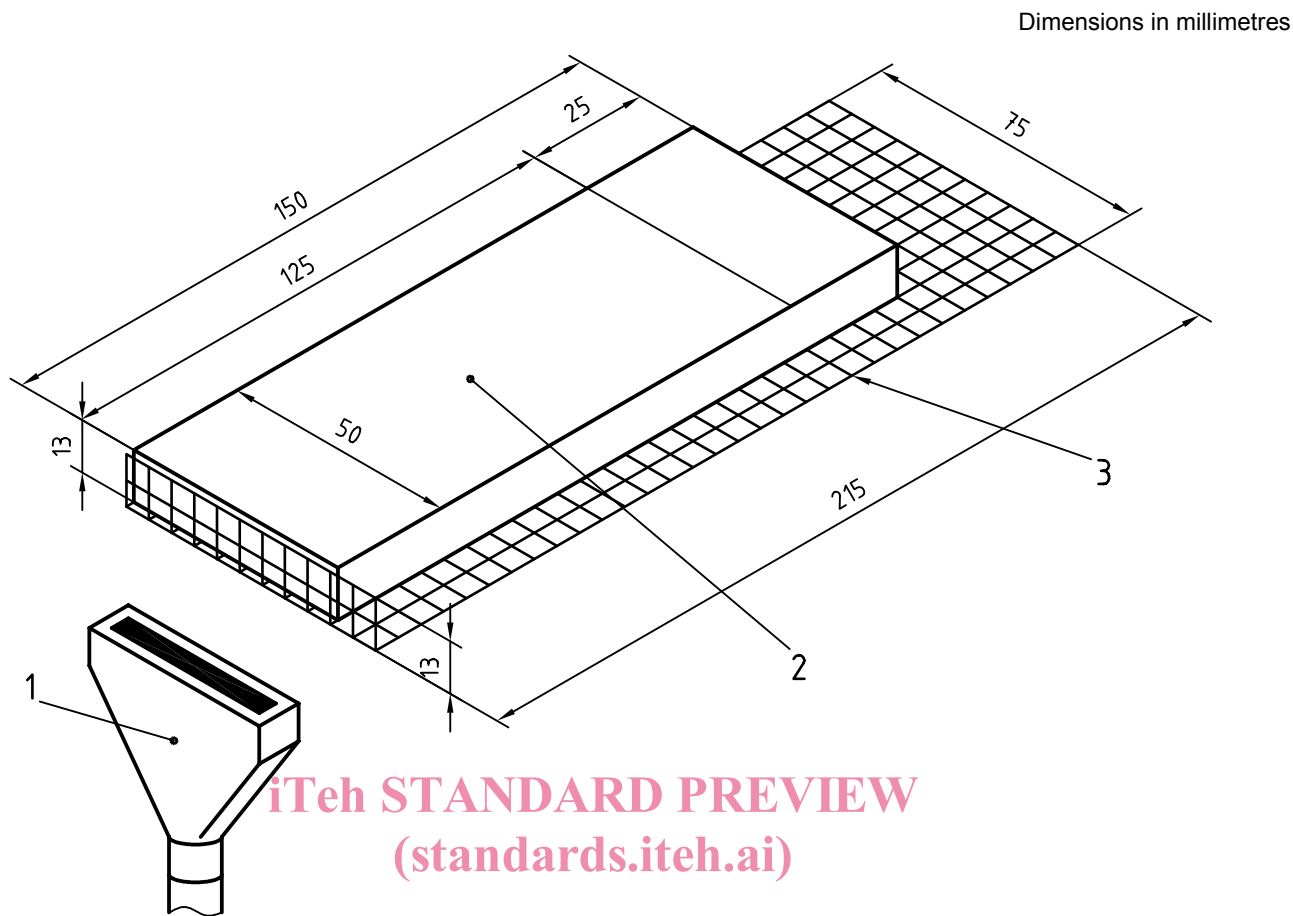

ISO 3582:2000

<https://standards.iteh.ai/catalog/standards/sist/d166c3ee-6f82-4613-b810-7274c02b9f17/iso-3582-2000>

Key

- 1 Burner wing top
- 2 Test piece
- 3 Test piece support gauze

Figure 3 — Test piece and test piece support gauze

5.5 Support-gauze holder, constructed from mild steel as shown in Figure 4 so that:

- a) the gauze is maintained with its long axis within 1° of the horizontal, and parallel to the 600 mm dimension of the test chamber;
- b) the nearest end of the test piece is $13 \text{ mm} \pm 1 \text{ mm}$ above the burner wing top (see Figure 2);
- c) the space both above and below the test piece is unobstructed;
- d) means is provided for positioning the burner in the correct position relative to the test piece;
- e) the gauze is equidistant from the front, back and sides of the test chamber, and is $175 \text{ mm} \pm 25 \text{ mm}$ above the base of the test chamber.

5.6 Timing device, accurate to $\pm 1 \text{ s}$.

5.7 Measuring scale, graduated in millimetres.

5.8 Balance (if necessary), accurate to $\pm 1 \text{ mg}$.