Thermoplastics pipes for the conveyance of fluids — Determination of resistance to rapid crack propagation (RCP) — Full-scale test (FST)

Tubes en matières thermoplastiques pour le transport des fluides — Détermination de la résistance à la propagation rapide de la fissure (RCP) — Essai grandeur nature (FST)

iTeh STANDARD PREVIEW
(standards.iteh.ai)

ISO 13478:1997

<https://standards.iteh.ai/catalog/standards/sist/49eeb57a-750a-4104-9337-a89227e3afc0/iso-13478-1997>

STANDARD

13478



Foreword

ISO (the International Organization for Standardization) is a worldwide federation of national standards bodies (ISO member bodies). The work of preparing International Standards is normally carried out through ISO technical committees. Each member body interested in a subject for which a technical committee has been established has the right to be represented on that committee. International organizations, governmental and non-governmental, in liaison with ISO, also take part in the work. ISO collaborates closely with the International Electrotechnical Commission (IEC) on all matters of electrotechnical standardization.

Draft International Standards adopted by the technical committees are circulated to the member bodies for voting. Publication as an International Standard requires approval by at least 75 % of the member bodies casting a vote.

International Standard ISO 13478 was prepared by Technical Committee ISO/TC 138, *Plastics pipes, fittings and valves for the transport of fluids*, Subcommittee SC 5, *General properties of pipes, fittings and valves of plastic materials and their accessories — Test methods and basic specifications*.

<https://standards.iteh.ai/catalog/standards/sist/49eeb57a-750a-4104-9337-189227e3af01/iso-13478-1997>

Annexes A and B form an integral part of this International Standard.

© ISO 1997

All rights reserved. Unless otherwise specified, no part of this publication may be reproduced or utilized in any form or by any means, electronic or mechanical, including photocopying and microfilm, without permission in writing from the publisher.

International Organization for Standardization
Case postale 56 • CH-1211 Genève 20 • Switzerland
Internet central@iso.ch
X.400 c=ch; a=400net; p=iso; o=isocs; s=central

Printed in Switzerland

Thermoplastics pipes for the conveyance of fluids — Determination of resistance to rapid crack propagation (RCP) — Full-scale test (FST)

1 Scope

This International Standard specifies a full-scale method of test for determination of arrest or propagation of a crack initiated in a thermoplastics pipe at a specified temperature and internal pressure.

It is applicable to the assessment of the performance of thermoplastics pipes intended for the supply of gases or liquids, in the latter case when air may also be present in the pipe.

iTeh STANDARD PREVIEW
(standards.iteh.ai)

2 Normative references

The following standards contain provisions which, through reference in this text, constitute provisions of this International Standard. At the time of publication, the editions indicated were valid. All standards are subject to revision, and parties to agreements based on this International Standard are encouraged to investigate the possibility of applying the most recent editions of the standards indicated below. Members of IEC and ISO maintain registers of currently valid International Standards.

ISO 1167:1996, *Thermoplastics pipes for the conveyance of fluids — Resistance to internal pressure — Test method*.

ISO 3126:1974, *Plastics pipes — Measurement of dimensions*.

ISO 11922-1:1997, *Thermoplastics pipes for the conveyance of fluids — Dimensions and tolerances — Part 1: Metric series*.

3 Definitions

For the purposes of this International Standard, the definitions given in ISO 11922-1 apply.

4 Principle

A thermoplastics pipe, maintained at a specified temperature and containing a fluid at a specified test pressure, is subjected to an impact designed to initiate a crack.

The test temperature and test pressure are as defined in the referring standard.

The fluid is identical to that used in the intended application, or is a substitute fluid which gives equivalent results.

The test simulates the performance of a buried pipe in service under conditions which do not retard the rate of decompression of the pressurizing fluid through any fracture.

The pipe is subsequently examined to determine whether arrest or propagation of the crack has occurred.

From a series of such tests at different pressures but at constant temperature, a critical pressure or critical stress for crack propagation can be determined (see annex A for further information).

Similarly, by testing at a series of temperatures whilst maintaining a constant pressure or hoop stress, the critical temperature for crack propagation can be determined (see annex B for further information).

5 Test parameters

It is assumed that the following parameters will be set by the referring product standard:

- a) the diameter(s) and series of the pipe(s) to be tested;
- b) the pressurizing fluid (6.4), e.g. gas, water, water plus air;
- c) the test pressure(s);
- d) the test temperature(s).

iTeh STANDARD PREVIEW
(standards.iteh.ai)

6 Materials

6.1 Methylated spirits, for use as a cooling fluid (see 7.4.3).

ISO 13478:1997
<https://standards.iteh.ai/catalog/standards/sist/49eeb57a-750a-4104-9337-89227e3ef0/iso-13478-1997>

6.2 Solid carbon dioxide, for use as a cooling agent (see 7.4.3).

6.3 Washed gravel, with a size range of 20 mm to 40 mm diameter (see clause 9).

6.4 Pressurizing fluid, which shall be as specified in the referring standard.

NOTES

1 It is satisfactory to use nitrogen or air as the pressurizing fluid instead of natural gas, as the measured pressure for rapid crack propagation (RCP) will be only slightly less than that obtained with natural gas. The decompression speed (velocity of sound) at 0 °C of nitrogen and air is 337 m/s and 334 m/s, respectively, compared with approximately 430 m/s for natural gas.

2 In water-pipeline systems which contain water only, the phenomenon of crack propagation is unlikely to occur. However, when entrained air bubbles or air pockets are present it is possible. It is usual to test with between 5 % and 10 % by volume of air in the water to determine the resistance to crack propagation. A test on water pipe using 100 % gas or air should be expected to give a pessimistic result.

7 Apparatus

7.1 Temperature-controlled trough, capable of accommodating the minimum test-pipe length of 14 m. The trough shall have means for maintaining the temperature specified by the referring standard to within $\pm 1,5$ °C along the whole test-pipe length by means of a water-recirculation system around the test pipe (see figure 1). If necessary, the water shall contain an antifreeze to avoid ice build-up round the test pipe.

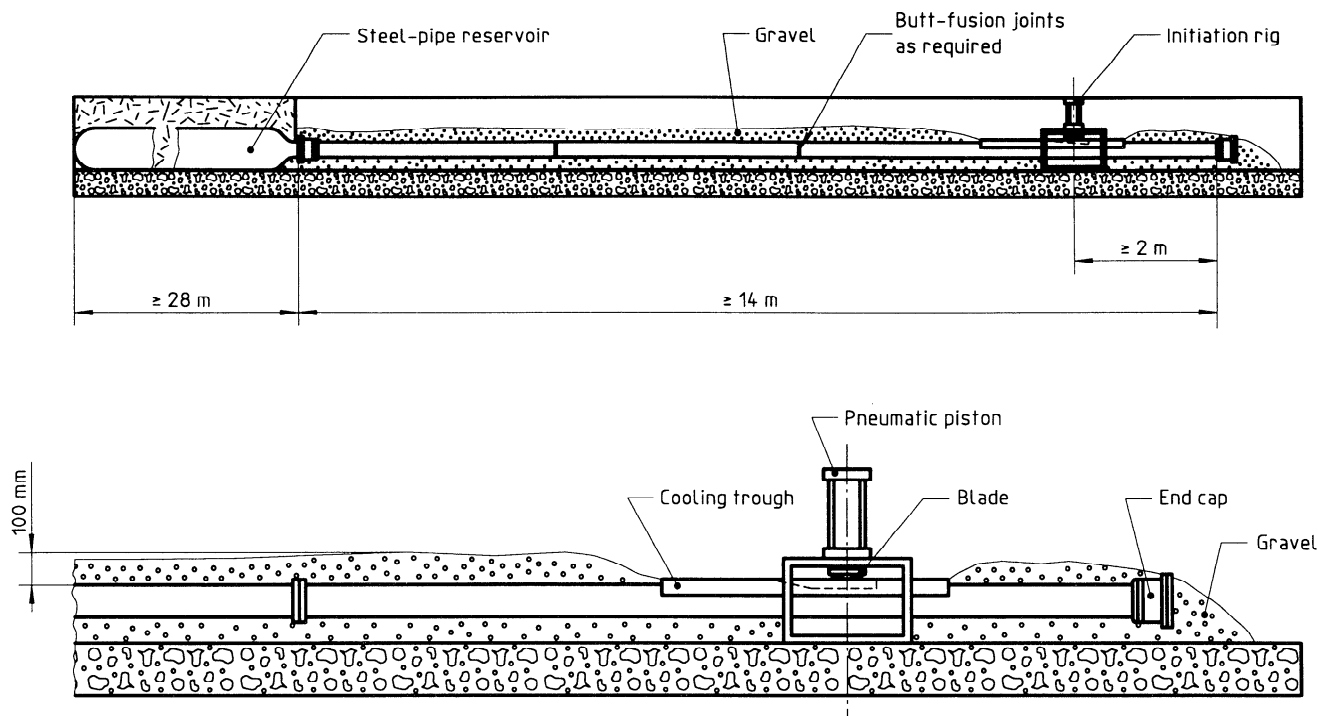

Figure 1 — Example of a test facility for full-scale rapid crack propagation

7.2 Steel-pipe reservoir, connected to the test pipe at one end of the trough. The steel pipe shall have a bore diameter equal to or greater than the test-pipe bore diameter. The pipe reservoir shall have a minimum length of twice that of the test pipe and a minimum volume of three times that of the test pipe.

7.3 Pressurization equipment, for pressurizing the test pipe and steel reservoir (7.2) with the test fluid (6.4) to within $\pm 2\%$ of the test pressure specified by the referring standard.

7.4 Crack-initiation equipment.

7.4.1 Router, capable of machining a longitudinal groove to an appropriate depth in the test-pipe wall for approximately 500 mm and then gradually decreasing the groove depth to zero over approximately 250 mm (see figure 2).

7.4.2 Metal blade, which can be aligned with the external groove in the test pipe and be driven through the residual pipe-wall thickness.

NOTE — A 400-mm-long steel blade driven by a fast-acting pneumatic piston has been found to be suitable for polyethylene pipe (see figure 3).

Dimensions in millimetres

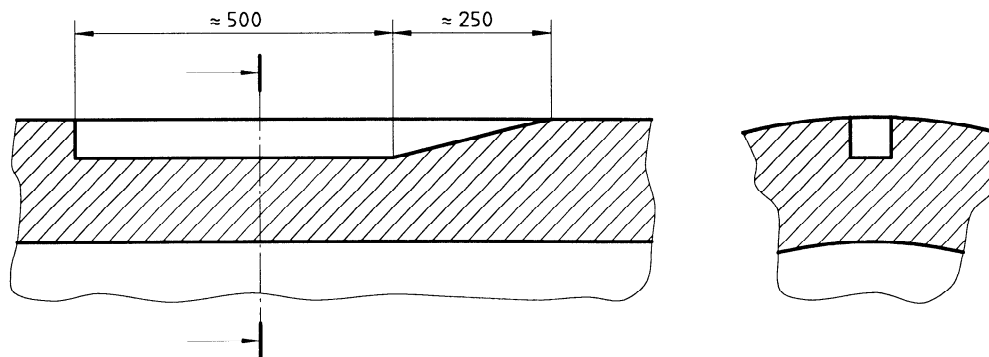
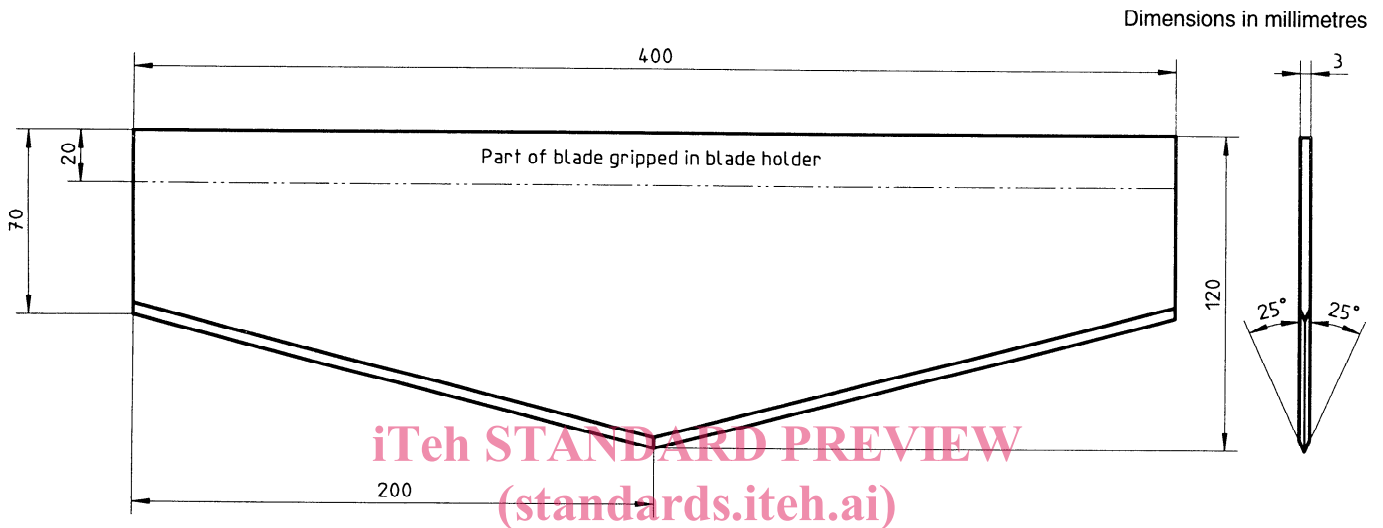

Figure 2 — Groove machined in external pipe wall

7.4.3 Cooling system, designed to apply methylated spirits cooled by solid carbon dioxide to the top of the pipe to cool a strip of pipe either side of the groove and approximately 1 m in the direction of the steel-pipe reservoir. It is recommended to use a wooden frame, resting on the top of the pipe and lined with a thin polyethylene sheet, to contain the cooling fluid (see figure 4).

7.4.4 Close-fitting wooden plug, approximately 0,5 m long, to support the test pipe internally beneath the groove sufficiently to prevent severe pipe distortion during crack initiation (see figure 4).

The top of the wooden plug shall have a recess containing compressible foam. The foam shall be compressed to maintain close contact with the pipe bore beneath the groove, even during pressurization. This will ensure that the wooden plug stays in position. Moreover, it will enable the full thickness of the groove ligament to be properly cooled by the cooling fluid (see 7.4.3) by insulating this part of the pipe bore from the pressurizing fluid.



NOTE — Blade sharpened by light grinding.

Figure 3 — Steel blade found to be suitable for initiating a crack in polyethylene pipe

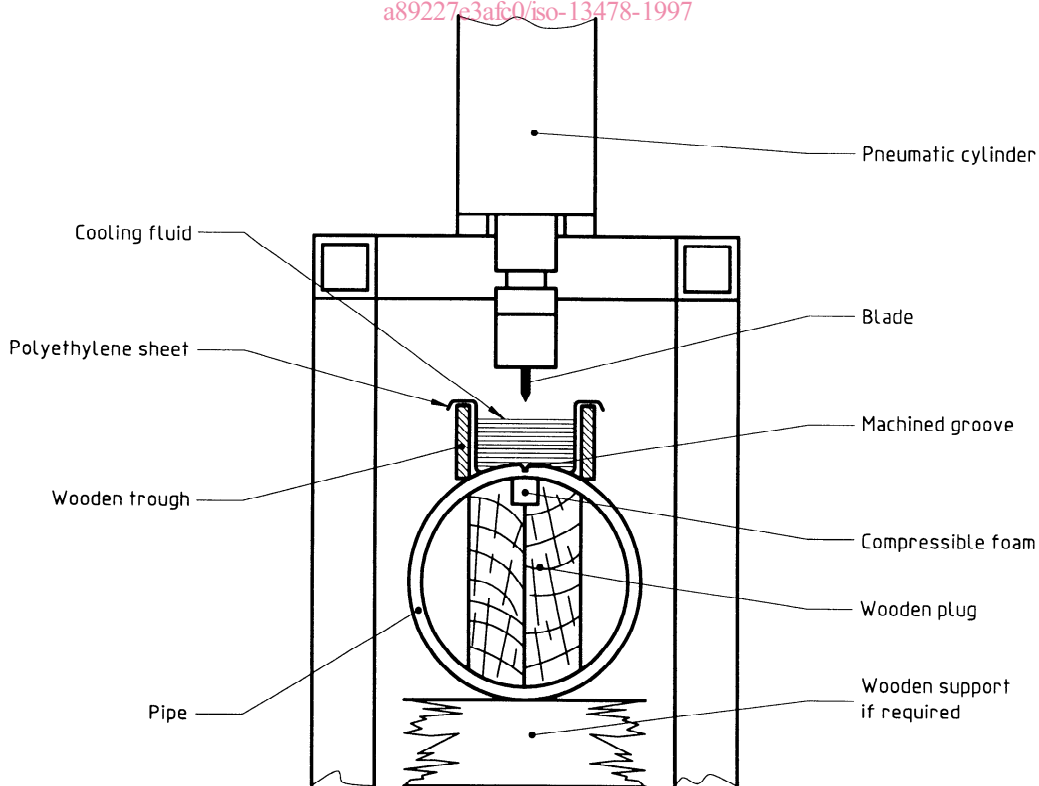

Figure 4 — Example of the crack-initiation position

8 Test-pipe preparation

If required, joint straight sections of pipe together by butt fusion to produce a test pipe of minimum length 14 m.

Measure the location of any butt-fusion joint.

Insert the wooden plug (7.4.4) and locate it underneath the position where the groove will be produced. The centre of the groove shall be at least 2 m from the pipe end.

Fit, to the end of the test pipe nearest the groove, an end cap which will withstand the end load from the test pressure (see figure 1).

Lay the test pipe in the trough and connect the other end of the test pipe to the steel-pipe reservoir (7.2). Ensure visually that the test pipe is straight.

Within the zone supported by the wooden plug, use the router to machine, in the external surface of the test pipe, a longitudinal groove having a depth which is constant for approximately 500 mm. Then decrease the depth gradually to zero over approximately 250 mm in the direction of the steel-pipe reservoir (see figure 2).

When testing highly RCP-resistant pipes, part of the pipe test section can be replaced by a crack-initiation pipe of a lower RCP resistance but of the same nominal diameter and wall thickness. The crack-initiation pipe shall replace the test pipe from the end cap to a distance of approximately 3 m beyond the crack-initiation position. A butt-fusion joint shall be used to connect the two pipes. It is not necessary to remove the external or internal beads.

The groove depth shall be chosen to create a sufficiently high stress to initiate a high-speed crack in the remaining ligament which will be at a temperature of approximately $-60\text{ }^{\circ}\text{C}$. However, the groove shall not be so deep that premature failure during pipe pressurization represents a safety hazard.

NOTE — A ligament stress of 20 MPa to 25 MPa has been found to be suitable for polyethylene pipes. In general, it is then not possible to pressurize the test pipe unless the groove ligament is also cooled to approximately $-60\text{ }^{\circ}\text{C}$.

ISO 13478:1997

9 Conditioning and backfill

<https://standards.iteh.ai/catalog/standards/sist/49eeb57a-750a-4104-9337-a89227e3afc0/iso-13478-1997>

Place gravel (6.3) round the pipe, covering it to a depth of 100 mm except for the top of the pipe around the crack-initiation position.

Place cross-beams lightly on the crown of the pipe at intervals of 1 m to 1,5 m and fasten them to the trench wall to ensure that the pipe will not rise and thus create significant bending stresses when the trough is filled with water. Omit the cross-beams when they would interfere with the wooden frame (see 7.4.3).

Fill the trough with water, if necessary containing a suitable quantity of antifreeze, to just below the level of the gravel.

Circulate the water along the trough, through the gravel and round the cooling system until the test temperature, as specified in the referring standard, is established to within $\pm 1,5\text{ }^{\circ}\text{C}$ all along the pipe.

The conditioning time shall be at least the conditioning time defined in ISO 1167 for the appropriate pipe wall thickness. Any conditioning fluids shall not affect the properties of the test pipe.

Maintain the test temperature within the tolerance range for a minimum period of 1 h immediately before testing in accordance with clause 10. The temperature shall be measured at intervals of approximately 2 m alternating along either side of the test pipe from the end of the wooden frame to the steel-pipe reservoir.

10 Test procedure

10.1 Cool the crack-initiation groove with the mixture of methylated spirits and solid carbon dioxide (see 7.4.3) at approximately $-60\text{ }^{\circ}\text{C}$ for at least 1 h to ensure that the full wall thickness around the groove and 1 m in the direction of the steel-pipe reservoir are adequately cooled.

10.2 Pressurize the test pipe and reservoir with the specified test fluid to the test pressure to within $\pm 2\%$. If the test fluid is not entering the pipe at approximately the specified test temperature, then an additional pipe-conditioning period will be required to ensure that the test pipe is uniformly at the test temperature both internally and externally.

NOTES

1 Once the test pipe starts to be pressurized, then there is a potentially serious hazard from premature bursting of the pipe and thrown gravel.

2 During the additional cooling period, there must, of course, be sufficient cooling fluid (see 7.4.3) to maintain the temperature of the groove ligament at $-60\text{ }^{\circ}\text{C}$.

10.3 Initiate cracking by driving the metal blade through the cooled, grooved section of the pipe where the groove is at full depth and the pipe is supported by the wooden plug (see figure 2).

10.4 Recover the test pipe and measure the longitudinal distance travelled by all the cracks from the centre of crack-initiation. When a crack-initiation pipe is used (see clause 8), the crack lengths are measured from the butt-fusion joint between the initiation pipe and the test pipe.

11 Interpretation of results

Crack arrest is defined as having taken place when the length of the longest crack is less than or equal to 90 % of the length of the test pipe.

Rapid crack propagation (RCP) is defined as having taken place when the length of the longest crack is greater than 90 % of the length of the test pipe.

12 Validity of results

For each test pipe, the longest crack shall meet all the following conditions:

- the crack shall travel beyond the cooled section of pipe round the groove, i.e. approximately 1,5 m from the centre of initiation;
- the crack shall not terminate by travelling completely round the pipe circumference so that it rejoins the original crack;
- the crack shall not terminate at a butt-fusion joint within the test pipe;
- when using a crack-initiation pipe (see clause 8), the crack shall propagate completely along the initiation pipe and enter the test pipe.

13 Test report

The test report shall include the following information:

- a reference to this International Standard and to the referring standard;
- all details necessary for complete identification of the test pipe and, if used, the crack-initiation pipe, including the manufacturer, the polymer used for manufacture, the production date and the identification marking on the pipe;

- c) the nominal pipe diameter and pipe series;
- d) the test-pipe length and, if used, the crack-initiation pipe length;
- e) the test pressure;
- f) the test temperature;
- g) the location(s) of the butt-fusion joint(s), if any;
- h) the crack lengths;
- i) a statement as to whether rapid crack propagation or arrest occurred;
- j) the date of test;
- k) details of any factors which may have affected the results, such as any incidents or any operations not specified in this International Standard.

iTeh STANDARD PREVIEW
(standards.iteh.ai)

[ISO 13478:1997](https://standards.iteh.ai/catalog/standards/sist/49eeb57a-750a-4104-9337-a89227e3afc0/iso-13478-1997)

<https://standards.iteh.ai/catalog/standards/sist/49eeb57a-750a-4104-9337-a89227e3afc0/iso-13478-1997>