**Textile conveyor belts — Full thickness
tensile testing —**

Part 1:

**Determination of tensile strength,
elongation at break and elongation at
the reference load**

iTeh STANDARD PREVIEW
(standards.iteh.ai)

*Courroies transporteuses à carcasse textile — Essai de traction en pleine
épaisseur —*

*Partie 1: Détermination de la résistance à la traction, de l'allongement à
la rupture et de l'allongement sous charge de référence*



PDF disclaimer

This PDF file may contain embedded typefaces. In accordance with Adobe's licensing policy, this file may be printed or viewed but shall not be edited unless the typefaces which are embedded are licensed to and installed on the computer performing the editing. In downloading this file, parties accept therein the responsibility of not infringing Adobe's licensing policy. The ISO Central Secretariat accepts no liability in this area.

Adobe is a trademark of Adobe Systems Incorporated.

Details of the software products used to create this PDF file can be found in the General Info relative to the file; the PDF-creation parameters were optimized for printing. Every care has been taken to ensure that the file is suitable for use by ISO member bodies. In the unlikely event that a problem relating to it is found, please inform the Central Secretariat at the address given below.

iTeh STANDARD PREVIEW
(standards.iteh.ai)

ISO 283-1:2000

<https://standards.iteh.ai/catalog/standards/sist/e8cfe647-5bf4-4523-a066-2bad3f5018f0/iso-283-1-2000>

© ISO 2000

All rights reserved. Unless otherwise specified, no part of this publication may be reproduced or utilized in any form or by any means, electronic or mechanical, including photocopying and microfilm, without permission in writing from either ISO at the address below or ISO's member body in the country of the requester.

ISO copyright office
Case postale 56 • CH-1211 Geneva 20
Tel. + 41 22 749 01 11
Fax + 41 22 749 09 47
E-mail copyright@iso.ch
Web www.iso.ch

Printed in Switzerland

Foreword

ISO (the International Organization for Standardization) is a worldwide federation of national standards bodies (ISO member bodies). The work of preparing International Standards is normally carried out through ISO technical committees. Each member body interested in a subject for which a technical committee has been established has the right to be represented on that committee. International organizations, governmental and non-governmental, in liaison with ISO, also take part in the work. ISO collaborates closely with the International Electrotechnical Commission (IEC) on all matters of electrotechnical standardization.

International Standards are drafted in accordance with the rules given in the ISO/IEC Directives, Part 3.

Draft International Standards adopted by the technical committees are circulated to member bodies for voting. Publication as an International Standard requires approval by at least 75 % of member bodies casting a vote.

Attention is drawn to the possibility that some of the elements of this part of ISO 283 may be the subject of patent rights. ISO shall not be held responsible for identifying any or all such patent rights.

International Standard ISO 283-1 was prepared by the European Committee for Standardization (CEN) in collaboration with ISO Technical Committee TC 41, *Pulleys and belts (including veebelts)*, Subcommittee SC 3, *Conveyor belts*, in accordance with the Agreement on technical cooperation between ISO and CEN (Vienna Agreement).

iTeh STANDARD PREVIEW

Throughout the text of this standard, read "(this European Standard)" to mean "...this International Standard...".

This first edition of ISO 283-1, together with ISO 283-2, cancels and replaces ISO 283:1990, which has been technically revised.

<https://standards.iteh.ai/catalog/standards/sist/e8cfe647-5bf4-4523-a066-2bd365018f0/iso-283-1-2000>

ISO 283 consists of the following parts, under the general title *Textile conveyor belts — Full thickness tensile testing*:

- *Part 1: Determination of tensile strength, elongation at break and elongation at the reference load*
- *Part 2: Performance requirements*

Contents

	Page
Foreword.....	v
1 Scope.....	1
2 Normative references.....	1
3 Terms and definitions	1
4 Principle	2
5 Apparatus.....	2
6 Test pieces.....	3
7 Conditioning of test pieces.....	7
8 Procedure.....	7
9 Calculation and expression of results.....	8
10 Test report.....	9

iTeh STANDARD PREVIEW
(standards.iteh.ai)

<https://standards.iteh.ai/catalog/standards/sist/e8cfe647-5bf4-4523-a066-2bad3f5018f0/iso-283-1-2000>

Foreword

The text of EN ISO 283-1:2000 has been prepared by Technical Committee CEN/TC 188 "Conveyor belts", the secretariat of which is held by BSI, in collaboration with Technical Committee ISO/TC 41 "Pulleys and belts (including veebelts)".

This European Standard shall be given the status of a national standard, either by publication of an identical text or by endorsement, at the latest by April 2001, and conflicting national standards shall be withdrawn at the latest by April 2001.

According to the CEN/CENELEC Internal Regulations, the national standards organizations of the following countries are bound to implement this European Standard: Austria, Belgium, Czech Republic, Denmark, Finland, France, Germany, Greece, Iceland, Ireland, Italy, Luxembourg, Netherlands, Norway, Portugal, Spain, Sweden, Switzerland and the United Kingdom.

iTeh STANDARD PREVIEW (standards.iteh.ai)

[ISO 283-1:2000](https://standards.iteh.ai/catalog/standards/sist/e8cfe647-5bf4-4523-a066-2bad3f5018f0/iso-283-1-2000)

<https://standards.iteh.ai/catalog/standards/sist/e8cfe647-5bf4-4523-a066-2bad3f5018f0/iso-283-1-2000>

iTeh STANDARD PREVIEW
(standards.iteh.ai)

ISO 283-1:2000

<https://standards.iteh.ai/catalog/standards/sist/e8cfe647-5bf4-4523-a066-2bad3f5018f0/iso-283-1-2000>

1 Scope

This European Standard describes a method of test for determining the full thickness tensile strength, elongation at break and elongation at the reference load of conveyor belts having a textile construction.

Methods are in development for tensile strengths greater than 2500 N/mm.
This standard is not suitable or valid for light conveyor belts as described in EN 873.

2 Normative references

This European Standard incorporates by dated or undated reference, provisions from other publications. These normative references are cited at the appropriate places in the text and the publications are listed hereafter. For dated references, subsequent amendments to or revisions of any of these publications apply to this European Standard only when incorporated in it by amendment or revision. For undated references the latest edition of the publication referred to applies (including amendments).

EN 873	Light conveyor belts - Principal characteristics and applications
EN 10002-2:1991	Metallic materials - Tensile testing - Part 2: Verification of the force measuring system of the tensile testing machines
ISO 7500-1:1999	Metallic materials - Verification of static uniaxial testing machines - Part 1: Tension/compression testing machines – Verification and calibration of the force-measuring system

<https://standards.iteh.ai/catalog/standards/sist/e8cfe647-5bf4-4523-a066-2bad3f5018f0/iso-283-1-2000>

3 Terms and definitions

For the purposes of this Part of EN ISO 283 the following terms and definitions apply:

3.1

tensile strength

greatest measured force during the tensile test divided by the width of the test piece. It is expressed in N/mm.

3.2

nominal tensile strength

specified minimum value of the tensile strength expressed in N/mm.

3.3

reference force (reference load)

One-tenth of the nominal tensile strength in the longitudinal direction multiplied by the width of the test piece in mm. It is expressed in newtons.

Example:

Nominal tensile strength = 1600 N/mm

Reference force = 160 N/mm

Reference force for 25 mm test piece = 25 mm x 160 N/mm = 4000 N.

3.4 elongation at break

elongation at the greatest force (load), expressed as the percentage increase in the distance between two reference points.

3.5 elongation at the reference force (load)

elongation at the reference force (load) in the longitudinal direction, expressed as the percentage increase in the distance between two reference points.

4 Principle

A test piece, cut from the full thickness of the conveyor belt, is extended under standard conditions using a tensile testing machine, until rupture of the test piece occurs.

5 Apparatus

5.1 Dynamometer, of CRE or CRT type, calibrated to Grade 1 of ISO 7500-1:1999, or EN 10002-2:1991 and capable of extending the test piece at a constant rate, without interruption, of 100 ± 10 mm/min.

5.2 Grips, the form of which should ensure perfect fixing of the test piece and eliminate any possibility of slip during the tensile test. The use of grip with transverse serrations in accordance with Figure 1 is recommended.

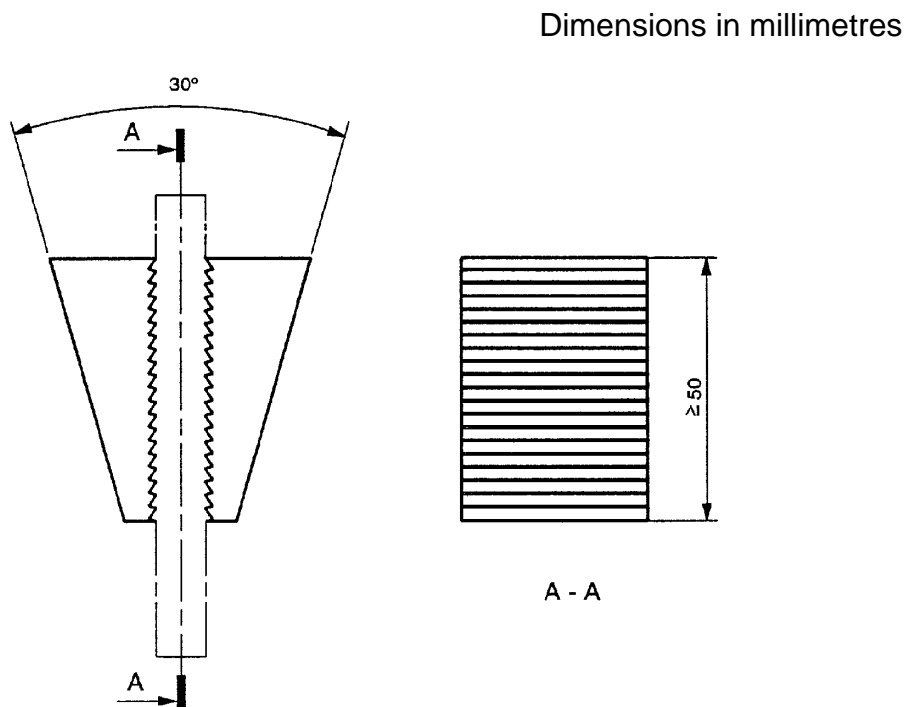

Figure 1 - Grip with transverse serrations

5.3 Die cutter or power saw. Dies with wall profiles as shown in Figure 2 are suitable for cutting the test pieces shown in Figures 3, 4 and 5. Other profiles may be used but the critical feature is that the cut sides of the test piece are perpendicular to the test piece surfaces.

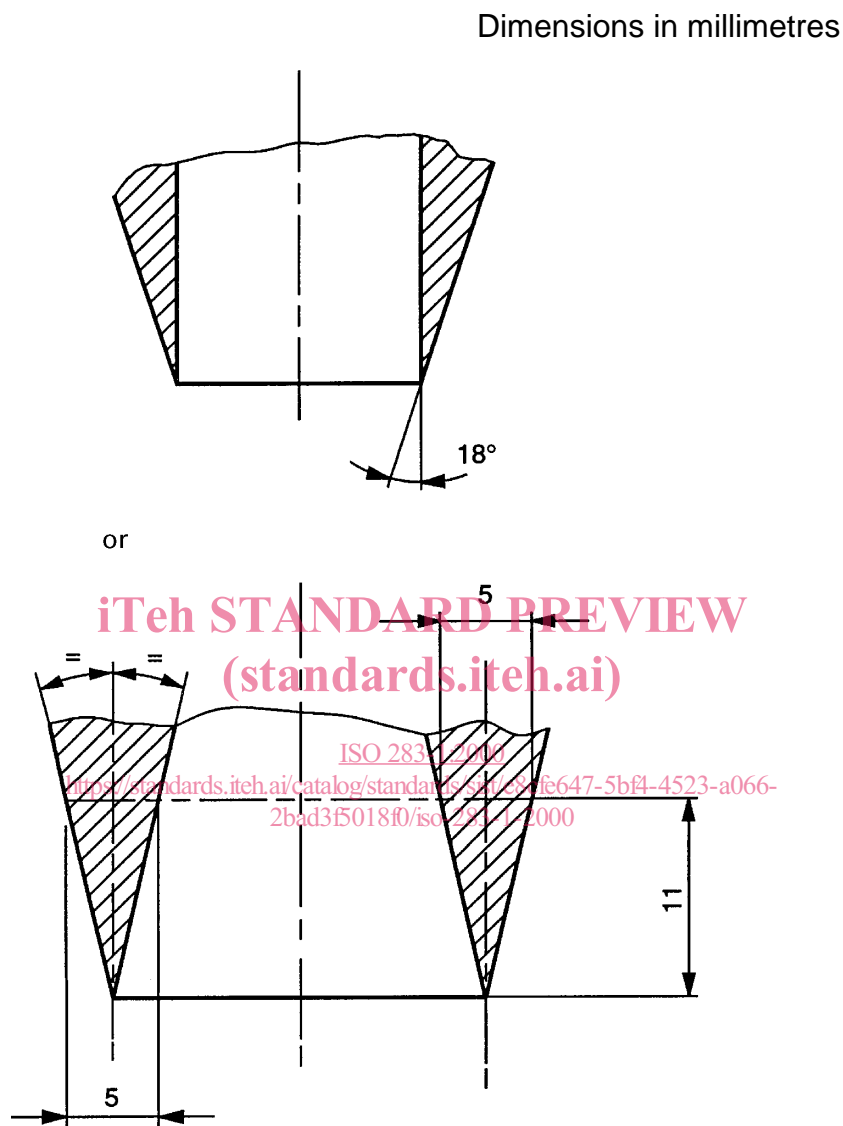

Figure 2 - Suitable die profiles

NOTE If rubber covers are to be cut it is advisable to moisten the die and surface to be cut with an aqueous solution.

6 Test pieces

6.1 Number of test pieces

Three test pieces shall be selected from the longitudinal direction of the belt and three test pieces shall be selected from the transverse direction of the belt.