



SLOVENSKI STANDARD

SIST EN 1402-4:2004

01-maj-2004

BUXca Yý U
SIST ENV 1402-4:2000

Neoblikovani ognjevzdržni izdelki - 4. del: Ugotavljanje konsistence gostih litih betonov

Unshaped refractory products - Part 4: Determination of consistency of castables

Ungeformte feuerfeste Erzeugnisse - Teil 4: Bestimmung der Konsistenz von Feuerbetonen

iTeh STANDARD PREVIEW

(standards.iteh.ai)

Produits réfractaires non façonnés - Partie 4: Détermination de la consistance des bétons

[SIST EN 1402-4:2004](#)

<https://standards.iteh.ai/catalog/standards/sist/32313d3b-cca6-4d1e-861e-88f7e247e38e/sist-en-1402-4-2004>

Ta slovenski standard je istoveten z: EN 1402-4:2003

ICS:

81.080

Ognjevzdržni materiali

Refractories

SIST EN 1402-4:2004

en

iTeh STANDARD PREVIEW
(standards.iteh.ai)

[SIST EN 1402-4:2004](#)

<https://standards.iteh.ai/catalog/standards/sist/32313d3b-cca6-4d1e-861e-88f7e247e38e/sist-en-1402-4-2004>

EUROPEAN STANDARD
NORME EUROPÉENNE
EUROPÄISCHE NORM

EN 1402-4

October 2003

ICS 81.080

Supersedes ENV 1402-4:1999

English version

Unshaped refractory products - Part 4: Determination of consistency of castables

Produits réfractaires non façonnés - Partie 4:
Détermination de la consistance des bétons

Ungeformte feuerfeste Erzeugnisse - Teil 4: Bestimmung
der Konsistenz von Feuerbetonen

This European Standard was approved by CEN on 20 June 2003.

CEN members are bound to comply with the CEN/CENELEC Internal Regulations which stipulate the conditions for giving this European Standard the status of a national standard without any alteration. Up-to-date lists and bibliographical references concerning such national standards may be obtained on application to the Management Centre or to any CEN member.

This European Standard exists in three official versions (English, French, German). A version in any other language made by translation under the responsibility of a CEN member into its own language and notified to the Management Centre has the same status as the official versions.

iTeh STANDARD PREVIEW

CEN members are the national standards bodies of Austria, Belgium, Czech Republic, Denmark, Finland, France, Germany, Greece, Hungary, Iceland, Ireland, Italy, Luxembourg, Malta, Netherlands, Norway, Portugal, Slovakia, Spain, Sweden, Switzerland and United Kingdom.

[SIST EN 1402-4:2004](https://standards.iteh.ai/catalog/standards/sist/32313d3b-cca6-4d1e-861e-88f7e247e38e/sist-en-1402-4-2004)

<https://standards.iteh.ai/catalog/standards/sist/32313d3b-cca6-4d1e-861e-88f7e247e38e/sist-en-1402-4-2004>



EUROPEAN COMMITTEE FOR STANDARDIZATION
COMITÉ EUROPÉEN DE NORMALISATION
EUROPÄISCHES KOMITEE FÜR NORMUNG

Management Centre: rue de Stassart, 36 B-1050 Brussels

Contents

	page
Foreword.....	3
1 Scope	4
2 Normative references	4
3 Principle	4
4 Apparatus	5
5 Procedure	7
5.1 Determination of the consistency of insulating castables	7
5.2 Determination of the consistency of vibratable castables	7
6 Test report	9

iTeh STANDARD PREVIEW (standards.iteh.ai)

[SIST EN 1402-4:2004](https://standards.iteh.ai/catalog/standards/sist/32313d3b-cca6-4d1e-861e-88f7e247e38e/sist-en-1402-4-2004)

<https://standards.iteh.ai/catalog/standards/sist/32313d3b-cca6-4d1e-861e-88f7e247e38e/sist-en-1402-4-2004>

Foreword

This document (EN 1402-4:2003) has been prepared by Technical Committee CEN/TC 187 "Refractory products and materials", the secretariat of which is held by BSI.

This European Standard shall be given the status of a national standard, either by publication of an identical text or by endorsement, at the latest by April 2004, and conflicting national standards shall be withdrawn at the latest by April 2004.

This document supersedes ENV 1402-4:1999.

EN 1402 "Unshaped refractory products" consists of eight parts:

— *Part 1: Introduction and classification*

— *Part 2: Sampling for testing*

— *Part 3: Characterization as received*

— *Part 4: Determination of consistency of castables*

— *Part 5: Preparation and treatment of test pieces*

— *Part 6: Measurement of physical properties*

— *Part 7: Tests on pre-formed shapes*

— *Part 8: Determination of complementary properties*

According to the CEN/CENELEC Internal Regulations, the national standards organizations of the following countries are bound to implement this European Standard: Austria, Belgium, Czech Republic, Denmark, Finland, France, Germany, Greece, Hungary, Iceland, Ireland, Italy, Luxembourg, Malta, Netherlands, Norway, Portugal, Slovakia, Spain, Sweden, Switzerland and the United Kingdom.

iteh STANDARD PREVIEW
(standards.iteh.ai)

[SIST EN 1402-4:2004](#)

standards.iteh.ai/catalog/standards/sist/32313d3b-cca6-4d1e-861e-88f7e247e38e/sist-en-1402-4-2004

EN 1402-4:2003 (E)

1 Scope

This part of this European Standard describes methods for the determination of the consistency of dense and insulating castables as defined in EN 1402-1.

2 Normative references

This European Standard incorporates by dated or undated reference, provisions from other publications. These normative references are cited at the appropriate places in the text, and the publications are listed hereafter. For dated references, subsequent amendments to or revisions of any of these publications apply to this European Standard only when incorporated in it by amendment or revision. For undated references the latest edition of the publication referred to applies (including amendments).

EN 1402-1, *Unshaped refractory products - Part 1: Introduction and classification*.

EN 1402-5:2003, *Unshaped refractory products - Part 5: Preparation and treatment of test pieces*.

3 Principle

The amount of water used in a castable mix for preparing test pieces has a significant influence on the test results. Excess water can reduce strength, increase shrinkage, and can cause sedimentation; insufficient moisture can give voids due to poor compaction, with subsequent lower density and strength.

This European Standard describes procedures for determining and measuring the consistency of castables and is applicable to all types of dense regular castables, dense deflocculated castables and insulating castables to determine the liquid addition necessary for preparing test pieces according to EN 1402-5.

According to the different types of installation and types of castables, this European Standard is subdivided into three test methods:

- a) determination of the consistency of insulating castables containing significant amounts of light-weight aggregates such as vermiculite or perlite which would be destroyed by intensive mixing. Such products are normally installed by rodding;
- b) determination of the consistency of all types of vibratable castables;
- c) determination of the consistency of self-flowing castables.

To obtain reproducible results, the following factors shall be closely controlled:

- wet mixing time;
- batch size, which is chosen for the required number of determinations (e.g. if determination of working time is required), and is also related to mixer pan size or bowl;
- mixer pan size adapted to batch weight to have at least 50 % and a maximum of 75 %, volume loading by the dry batch;
- temperature (of the water, castable and mix and ambient temperature), of 18 °C to 22 °C for consistency and working time determination;
- quantity of water addition used in the test which is rapidly affected when the dry volume loading of the mixer pan drops below 50 % of the total dry capacity, due to the increased metal surface to be wetted;
- water quality.

4

4 Apparatus

4.1 **Mixer**, conforming to the requirements of 5.2 of EN 1402-5:2003.

4.2 **Vibrating table**, conforming to the requirements of 5.3 of EN 1402-5:2003.

4.3 **Trowel**, conforming to the requirements of 5.7 of EN 1402-5:2003.

4.4 **Metal moulds** (see Figures 1 and 2)

Two truncated cones, with a diameter of 100 mm at the bottom, and 70 mm at the top.

One cone shall be 50 mm in height and the other shall be 80 mm in height.

NOTE The moulds should preferably be made from stainless steel with chromium plated inside surfaces.

Dimensions in millimetres

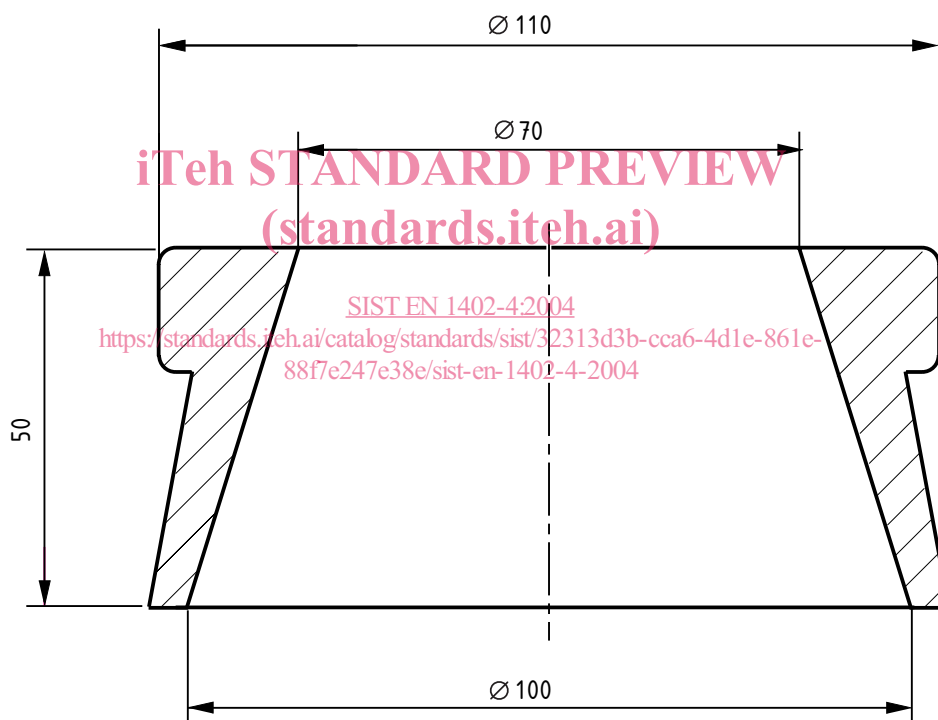

Figure 1 — Cone 1, of height 50 mm

Dimensions in millimetres

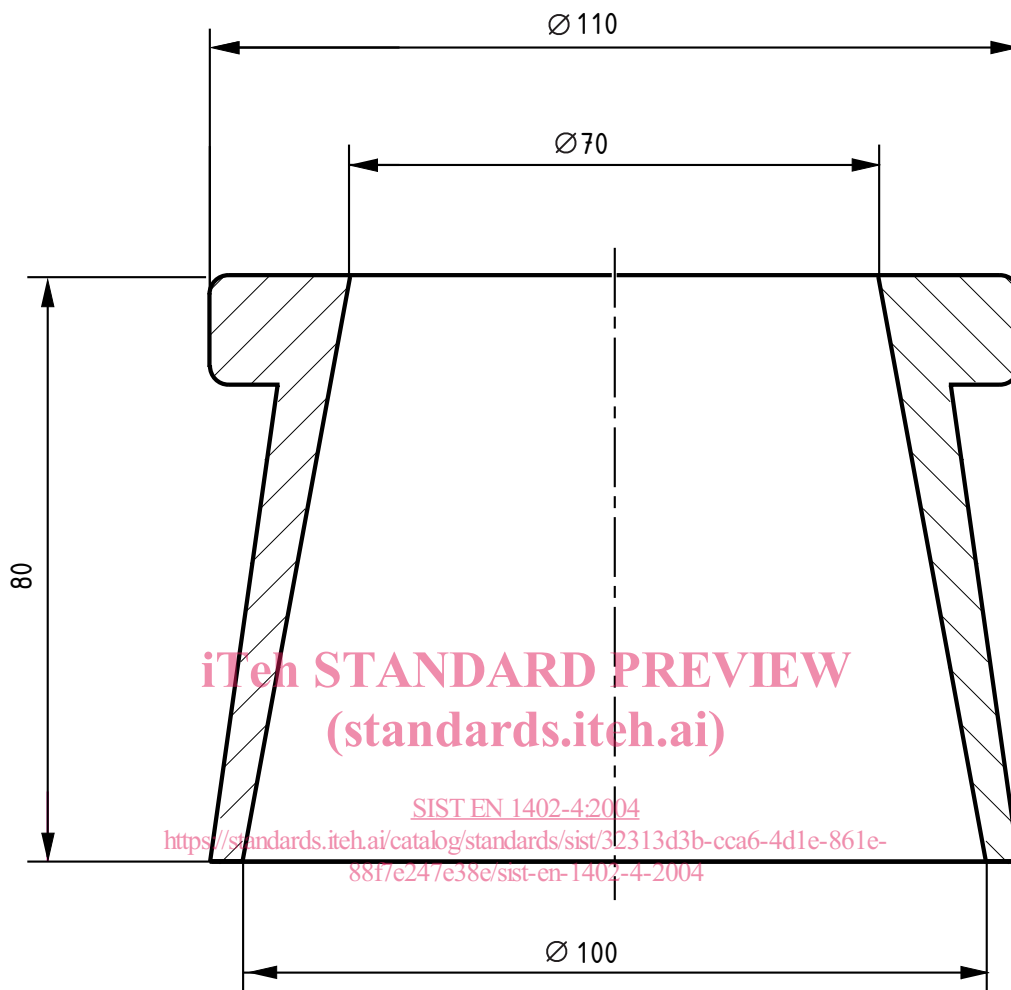

Figure 2 — Cone 2, of height 80 mm

4.5 Metal bowl, suitable for manual mixing of a test batch of correct size (for example a diameter of 450 mm and a depth of 150 mm is suitable for many products).

4.6 Balances, one capable of weighing up to 25 kg capable of measuring to the nearest 50 g and the other capable of weighing up to 5 kg capable of measuring to the nearest 1 g.

4.7 Stop-watch.

4.8 Callipers.

4.9 Thermometer, for measuring the temperature of the water, material and mix.

4.10 Water, pure mains water with a maximum hardness of 30°.

5 Procedure

5.1 Determination of the consistency of insulating castables

5.1.1 Weigh sufficient material to ensure filling 50 % to 60 % of the bowl volume of the dry sampled castable to the nearest 1 g and place it in the metal bowl (see 4.5) for manual mixing (see 6.2.1 of EN 1402-5:2003)

Place a known mass of water, at least twice as great as that of the castable sample, in a separate container with a pouring lip. If the manufacturer recommends a minimum quantity of water to be added, use an initial water addition of 75 % of this quantity, again weighed to the nearest 1 g. Where no recommendation is given, add a quantity of water just sufficient to wet the castable thoroughly, again weighed to the nearest 1 g. The temperature of the water and the castable shall be between 18 °C and 22 °C.

5.1.2 Mix this water manually with the castable until it is evenly dispersed. Make successive further small additions of water from a calibrated container, mixing with each addition until the mix begins to become a coherent mass. At this stage, reduce the water increments to a maximum of 1 % of the castable sample.

5.1.3 After each of these additions knock the bowl on a hard surface six times. A mix of the correct consistency should flow easily and form a shiny wet surface. If necessary, add water until this consistency is reached. Weigh the remaining water in the container and calculate the water addition made to the castable as a percentage of the dry castable mass. Record this percentage.

5.1.4 Leave the bowl for 5 min and again knock it six times on a hard surface to check the consistency. If necessary add small amounts of water to obtain the correct consistency, in which case the total amount of water added shall be reported. Do not allow the total time taken to achieve the correct consistency to exceed 20 min from the first addition of water.

NOTE After the mix has been left in the bowl for 5 min it can be necessary to stir it by hand, before making the further water additions.

5.1.5 Record the amount of water required for the correct consistency expressed in litres of water per hundred kilogrammes (l/100 kg) of dry castable.

5.2 Determination of the consistency of vibratable castables

5.2.1 Weigh a sufficient quantity of the sampled castable to obtain at least 50 % (preferably 75 %) volume loading of the mixer pan by the dry batch. Place this weighed amount in the mixer pan (see 4.1).

5.2.2 In case of a multi-component material, weigh the equivalent amounts of each component and place them in the mixer pan. A separate dry mixing time of 1 min is necessary.

5.2.3 Switch on the mixer, start the stop-watch (see 4.7) and add, within 30 s, the average amount of water within the range recommended by the manufacturer.

NOTE 1 The wet mixing time should not be less than 2 min nor exceed 6 min, depending on the product type or the time recommended by the manufacturer.

NOTE 2 Generally, deflocculated castables require a longer mixing time than regular castables.

5.2.4 Fix the lightly oiled mould of suitable height (see 4.4), normally 50 mm, to the top surface of the vibrating table with its larger diameter (100 mm) facing downwards.

NOTE Within the wide range of castables some can have specific flow properties or coarse sizing. The 80 mm high cone should be used for products with a top sizing greater than 6,5 mm.

5.2.5 Place the mixed castable into the mould so that it forms a small heap above the top surface or rim of the mould within a maximum time of 30 s.