**Petroleum and natural gas industries —
Completion fluids and materials —**

**Part 1:
Measurement of viscous properties of
completion fluids**

iTeh STANDARD PREVIEW

*Industries du pétrole et du gaz naturel — Fluides de complétion et
matériaux*
(standards.iteh.ai)

Partie 1: Mesures des propriétés visqueuses des fluides de complétion

ISO 13503-1:2003

<https://standards.iteh.ai/catalog/standards/sist/df09de38-a2bd-47ea-82a2-48d8613a031e/iso-13503-1-2003>



PDF disclaimer

This PDF file may contain embedded typefaces. In accordance with Adobe's licensing policy, this file may be printed or viewed but shall not be edited unless the typefaces which are embedded are licensed to and installed on the computer performing the editing. In downloading this file, parties accept therein the responsibility of not infringing Adobe's licensing policy. The ISO Central Secretariat accepts no liability in this area.

Adobe is a trademark of Adobe Systems Incorporated.

Details of the software products used to create this PDF file can be found in the General Info relative to the file; the PDF-creation parameters were optimized for printing. Every care has been taken to ensure that the file is suitable for use by ISO member bodies. In the unlikely event that a problem relating to it is found, please inform the Central Secretariat at the address given below.

iTeh STANDARD PREVIEW
(standards.iteh.ai)

[ISO 13503-1:2003](https://standards.iteh.ai/catalog/standards/sist/df09de38-a2bd-47ea-82a2-48d8613a031e/iso-13503-1-2003)

<https://standards.iteh.ai/catalog/standards/sist/df09de38-a2bd-47ea-82a2-48d8613a031e/iso-13503-1-2003>

© ISO 2003

All rights reserved. Unless otherwise specified, no part of this publication may be reproduced or utilized in any form or by any means, electronic or mechanical, including photocopying and microfilm, without permission in writing from either ISO at the address below or ISO's member body in the country of the requester.

ISO copyright office
Case postale 56 • CH-1211 Geneva 20
Tel. + 41 22 749 01 11
Fax + 41 22 749 09 47
E-mail copyright@iso.org
Web www.iso.org

Published in Switzerland

Contents

Page

Foreword.....	iv
Introduction	v
1 Scope.....	1
2 Terms and definitions.....	1
3 Abbreviated terms.....	2
4 Measurement and precision.....	2
5 Fluid preparation.....	2
6 Fluid preparation using shear-history simulation (optional).....	3
6.1 General.....	3
6.2 Requirements for proper shear-history simulation.....	3
6.3 Conditions for sample delivery.....	3
6.4 Conditions for standard shear-history simulation.....	3
6.5 Operational considerations.....	4
7 Instrument calibration.....	5
8 Measurement procedures.....	5
8.1 General.....	5
8.2 Non-crosslinked fluids (see 2.6).....	5
8.3 Viscoelastic fluids.....	10
9 Calculation procedures.....	11
9.1 General concepts.....	11
9.2 Brief review of geometry-independent rheology vs. nominal rheology.....	12
9.3 Limitations/problems that may produce erroneous results.....	13
9.4 Calculation method for concentric-cylinder viscometers.....	13
9.5 Bingham plastic parameters for completion fluids.....	16
9.6 Calculations for optional shear-history simulation.....	16
10 Test report.....	17
Bibliography	20

Foreword

ISO (the International Organization for Standardization) is a worldwide federation of national standards bodies (ISO member bodies). The work of preparing International Standards is normally carried out through ISO technical committees. Each member body interested in a subject for which a technical committee has been established has the right to be represented on that committee. International organizations, governmental and non-governmental, in liaison with ISO, also take part in the work. ISO collaborates closely with the International Electrotechnical Commission (IEC) on all matters of electrotechnical standardization.

International Standards are drafted in accordance with the rules given in the ISO/IEC Directives, Part 2.

The main task of technical committees is to prepare International Standards. Draft International Standards adopted by the technical committees are circulated to the member bodies for voting. Publication as an International Standard requires approval by at least 75 % of the member bodies casting a vote.

Attention is drawn to the possibility that some of the elements of this document may be the subject of patent rights. ISO shall not be held responsible for identifying any or all such patent rights.

ISO 13503-1 was prepared by Technical Committee ISO/TC 67, *Materials, equipment and offshore structures for petroleum, petrochemical and natural gas industries*, Subcommittee SC 3, *Drilling and completion fluids, and well cements*.

iTeh STANDARD PREVIEW

ISO 13503 consists of the following parts, under the general title *Petroleum and natural gas industries — Completion fluids and materials*:

— *Part 1: Measurement of viscous properties of completion fluids*

ISO 13503-1:2003
<https://standards.itih.ai/catalog/standards/sist/df09de38-a2bd-47ea-82a2-48d8613a031e/iso-13503-1-2003>

The following part is under preparation:

— *Part 2: Measurement of properties of proppants used in hydraulic fracturing and gravel-packing operations*

Introduction

For the purpose of this part of ISO 13503, completion fluids are defined as viscosified treating fluids used during the completion or workover of a petroleum- or natural gas-producing well. The objective of this part of ISO 13503 is to provide a standard procedure for measuring the viscous properties of single-phase, non-particulate-laden completion fluids. These fluids are viscosified brines, gravel-pack carrier fluids, and fracturing fluids. These fluids can be either crosslinked or non-crosslinked (aqueous, hydrocarbon- or acid-based).

An optional shear-history simulation procedure is provided for fluids that are potentially shear-sensitive. This procedure is designed to simulate the shearing effects experienced by a fluid in surface apparatus and during the time it is being conveyed down the wellbore. Shear-history simulation is most often used during the development of new fracturing fluids to characterize their sensitivity to shear.

These standard procedures were compiled on the basis of several years of comparative testing, debate, discussion, and continued research by the industry.

This standard procedure is largely based on API RP 39, third edition, May 1998 [1].

In this part of ISO 13503, where practical, U.S. Customary units are included in parentheses for convenience.

iTeh STANDARD PREVIEW
(standards.iteh.ai)

[ISO 13503-1:2003](https://standards.iteh.ai/catalog/standards/sist/df09de38-a2bd-47ea-82a2-48d8613a031e/iso-13503-1-2003)

<https://standards.iteh.ai/catalog/standards/sist/df09de38-a2bd-47ea-82a2-48d8613a031e/iso-13503-1-2003>

iTeh STANDARD PREVIEW
(standards.iteh.ai)

ISO 13503-1:2003

<https://standards.iteh.ai/catalog/standards/sist/df09de38-a2bd-47ea-82a2-48d8613a031e/iso-13503-1-2003>

Petroleum and natural gas industries — Completion fluids and materials —

Part 1: Measurement of viscous properties of completion fluids

1 Scope

This part of ISO 13503 provides consistent methodology for determining the viscosity of completion fluids used in the petroleum and natural gas industries. For certain cases, methods are also provided to determine the rheological properties of a fluid.

2 Terms and definitions

For the purposes of this document, the following terms and definitions apply.

2.1

bob

fixed inner cylinder of a concentric-cylinder viscometer

2.2

completion fluid

any fluid used during the completion phase of a well

2.3

concentric-cylinder viscometer

rotational viscometer that consists of a concentric-cylindrical bob and a cylindrical rotor

2.4

elasticity

capability of a material to regain its original shape and condition upon removal of an acting stress

2.5

laminar flow

flow property of fluids in which all layers of the fluid move parallel to each other and no material is transferred between layers

2.6

non-crosslinked fluid

linear, polymer-viscosified solution or any fluid that does not exhibit significant elasticity leading to the Weissenberg effect (“bob climbing”)

2.7

rheology

science of the deformation and flow of matter

2.8

shear history

sequence of shear rates and temperatures applied to fluids prior to and during measurements

2.9

shear-history simulator

apparatus used to simulate shear history in a fluid

2.10

shear rate

rate at which one particle of fluid is sliding by another particle divided by the distance between those particles

2.11

shear stress

force required to sustain fluid flow

2.12

viscoelastic fluid

crosslinked polymer solution or other fluid that exhibits significant elasticity, leading to the Weissenberg effect (bob climbing)

2.13

viscosity

measure of the internal friction of a fluid when caused to flow by an external force

3 Abbreviated terms

iTeh STANDARD PREVIEW

(standards.iteh.ai)

r/min revolutions per minute

pH negative logarithm (to the base 10) of hydrogen ion concentration

ASTM American Society for Testing Materials

DIN Deutsches Institut für Normung

4 Measurement and precision

Temperatures shall be measured to an accuracy of ± 1 °C (± 2 °F); pH shall be measured to an accuracy of $\pm 0,1$ units. All other quantitative measurements shall be made to an accuracy of ± 2 %, unless specified otherwise.

5 Fluid preparation

Certain aspects of sample preparation and handling can affect the viscosity or rheological properties of a fluid. During all procedures, steps shall be taken to minimize entraining air into the fluid. Following preparation, all fluids, except those intended to be used as fracturing fluids, shall be filtered through a filter of pore diameter 2 μ m. Minimize the entrainment of air during the filtration process.

The procedure used to prepare the fluid sample shall be documented including the following information:

- a) description and/or composition of the base fluid. Preparation of the fluid shall be described, starting with the fluid source, such as deionized water, tap water, seawater (location), or type of oil;
- b) identification of mixing apparatus, container volume, and total volume of fluid prepared;
- c) identification of each fluid component and amount added;
- d) the order and method of addition of each component;

- e) mixing speeds, with time at each speed;
- f) ageing or holding time prior to measurements, if required;
- g) temperature (required only for fracturing fluids);
- h) pH (for aqueous fluids, where applicable);
- i) all other aspects of the fluid preparation which are known to affect the outcome of the viscosity measurement should be reported.

6 Fluid preparation using shear-history simulation (optional)

6.1 General

A shear-history simulation procedure is provided to simulate the effects of shear rate and time while a fluid is being conveyed down well tubulars. This procedure is intended to characterize the effect of shear history on fluid properties as part of the concept and development phase for a new fluid.

A shear-history apparatus is used to condition the fluid at specified shear rates, times and temperatures prior to injection into a viscometer. It consists of mixing apparatus, pumping apparatus and tubing to simulate significant aspects of the surface apparatus followed by shear conditions in the well tubulars. A shear-history apparatus that satisfies the requirements can be generically classified as a tube or pipe flow device that operates in the laminar flow regime. Flow shall occur in a single-pass mode.

A schematic diagram of a shear-history simulator connected to a pressurized concentric-cylinder viscometer is shown in Figure 1. In laminar flow, the energy dissipation rate is the same in any shear-history apparatus even if different tubing sizes are used. Thus the design and functioning of the apparatus can vary and still meet the desired preconditioning criteria.

6.2 Requirements for proper shear-history simulation

The following procedures shall be followed:

- a) record and report the test temperature;
- b) ensure thorough mixing of all fluid-activating additive(s) immediately before the fluid enters the shear-history tubing.

6.3 Conditions for sample delivery

The following conditions shall be fulfilled:

- a) continuous delivery of base fluid while additives are added and cup is being filled;
- b) constant shear rate within the shear-history tubing;
- c) while fluid is being injected into the viscometer, shear rate within gap of the viscometer is a nominal 100 s^{-1} .

6.4 Conditions for standard shear-history simulation

The following conditions shall be fulfilled:

- a) for fluid temperatures less than or equal to $93 \text{ }^\circ\text{C}$ ($200 \text{ }^\circ\text{F}$), shear rate 675 s^{-1} for 2,5 min;
- b) for fluid temperatures greater than $93 \text{ }^\circ\text{C}$ ($200 \text{ }^\circ\text{F}$), shear rate $1\,350 \text{ s}^{-1}$ for 5 min.

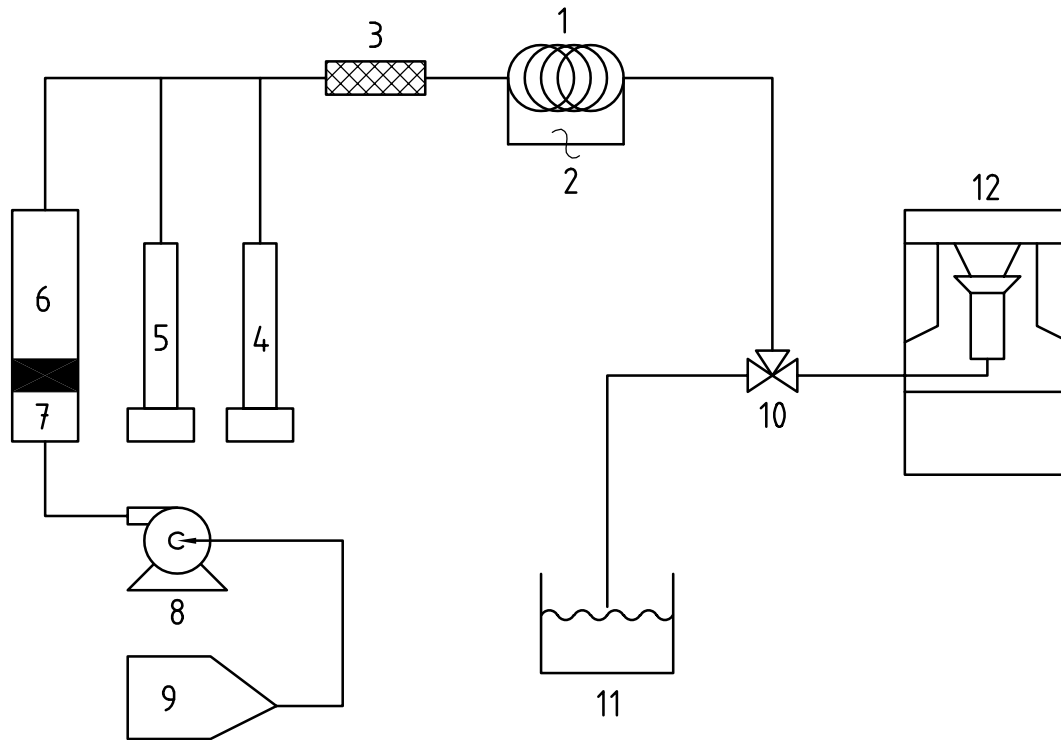

Key

- 1 tubing coil
- 2 differential pressure measurement device (optional)
- 3 static mixing device
- 4 high-pressure syringe pump for final additive e.g. crosslinker or activator
- 5 high-pressure syringe pump for second additive, if needed
- 6 base (e.g. uncrosslinked) fluid in floating-piston accumulator
- 7 oil from pump moving floating piston, which in turn moves base fluid
- 8 positive displacement pump
- 9 reservoir for pump oil
- 10 flow diversion valve
- 11 container for fluid
- 12 pressurized concentric-cylinder viscometer

iTeh STANDARD PREVIEW
(standards.iteh.ai)

ISO 13503-1:2003
<https://standards.iteh.ai/catalog/standards/sist/df09de38-a2bd-47ea-82a2-48d8613a031e/iso-13503-1-2003>

Figure 1 — Shear-history diagram

6.5 Operational considerations

The following conditions shall be fulfilled:

- a) the pulsation caused by certain types of positive displacement pumps shall be minimized;
- b) the base fluid shall be prepared, characterized and reported as described in Clause 5;
- c) it is critical that a representative sample of the test fluid be injected into the viscometer; therefore initially divert the fluid exiting the shear-history simulator away from the viscometer until stabilized flow and composition are established;
- d) unions, valves and similar fittings shall have internal diameters such that the shear rate of the fluid flowing through them is essentially the same as within the tubing;
- e) where the tubing is coiled, the diameter of the coil shall be larger than a critical value (see 9.6.2).

7 Instrument calibration

The instruments associated with these procedures shall be calibrated according to each manufacturer's recommended method.

8 Measurement procedures

8.1 General

The procedures given in this clause are organized based on the type of fluid on which the measurement is carried out. Where data are reported as being obtained using a particular procedure, the procedure given shall be followed exactly. The fluid shall not react with instrument surfaces to generate contaminants, change critical measurement dimensions, or impair proper mechanical operation.

8.2 Non-crosslinked fluids (see 2.6)

8.2.1 Introduction

For proper rheological characterization of this type of fluid, the fluid shall wet the walls of the measuring chamber and remain within the annular gap.

8.2.2 Apparatus

For proper viscometric and rheological characterization, the apparatus used shall meet the following criteria:

- a) the flow regime in the annular gap is laminar;
- b) slippage of the fluid at the walls within the gap is negligible;
- c) the fluid exhibits essentially time-independent behaviour during any given measurement.

8.2.2.1 Non-pressurized concentric-cylinder viscometer¹⁾, to measure viscous and rheological properties at ambient pressure and at temperatures below the boiling point of the fluid.

Multiple-point measurements may be suitable for the calculation of rheological parameters.

Any non-pressurized concentric-cylinder viscometer that is described by the following dimensions may be used (see Figure 2):

- a) rotor (or sleeve)
 - 1) inside diameter: 36,83 mm (1,450 in),
 - 2) should be concentric with bob and extend the full length of bob;
- b) bob
 - 1) diameter: 34,49 mm (1,358 in),
 - 2) cylinder length: 38 mm (1,496 in),
 - 3) cylindrical body with a flat, closed bottom and a tapered top with a truncated cone angle of 60° degrees.

1) Examples of non-pressurized concentric-cylinder viscometers are the Fann Model 35 viscometer equipped with rotor 1, bob 1 (R1B1) and appropriate spring; Chandler Model 3500 equipped with rotor 1 bob 1 (R1B1) and appropriate spring; OFI Model 800 equipped with rotor 1 bob 1 (R1B1) and appropriate spring; or viscometers with equivalent geometry. This information is given for the convenience of users of this part of ISO 13503 and does not constitute an endorsement by ISO of these products.