**Rubber- or plastics-coated fabrics —
Determination of resistance to combined
shear flexing and rubbing**

*Supports textiles revêtus de caoutchouc ou de plastique — Détermination
de la résistance au froissement dû à l'application simultanée d'un couple
et de frottement*

iTeh STANDARD PREVIEW
(standards.iteh.ai)

[ISO 5981:1997](https://standards.iteh.ai/catalog/standards/sist/f78c3c74-22f9-4998-8a41-ea523df13444/iso-5981-1997)

[https://standards.iteh.ai/catalog/standards/sist/f78c3c74-22f9-4998-8a41-
ea523df13444/iso-5981-1997](https://standards.iteh.ai/catalog/standards/sist/f78c3c74-22f9-4998-8a41-ea523df13444/iso-5981-1997)



Foreword

ISO (the International Organization for Standardization) is a worldwide federation of national standards bodies (ISO member bodies). The work of preparing International Standards is normally carried out through ISO technical committees. Each member body interested in a subject for which a technical committee has been established has the right to be represented on that committee. International organizations, governmental and non-governmental, in liaison with ISO, also take part in the work. ISO collaborates closely with the International Electrotechnical Commission (IEC) on all matters of electrotechnical standardization.

Draft International Standards adopted by the technical committees are circulated to the member bodies for voting. Publication as an International Standard requires approval by at least 75 % of the member bodies casting a vote.

International Standard ISO 5981 was prepared by Technical Committee ISO/TC 45, *Rubber and rubber products*. (standards.iteh.ai)

This second edition cancels and replaces the first edition (ISO 5981:1982), which has been technically revised.

© ISO 1997

All rights reserved. Unless otherwise specified, no part of this publication may be reproduced or utilized in any form or by any means, electronic or mechanical, including photocopying and microfilm, without permission in writing from the publisher.

International Organization for Standardization
Case postale 56 • CH-1211 Genève 20 • Switzerland
Internet central@iso.ch
X.400 c=ch; a=400net; p=iso; o=isocs; s=central

Printed in Switzerland

Rubber- or plastics-coated fabrics — Determination of resistance to combined shear flexing and rubbing

WARNING — Persons using this International Standard should be familiar with normal laboratory practice. This standard does not purport to address all of the safety problems, if any, associated with its use. It is the responsibility of the user to establish appropriate safety and health practices and to ensure compliance with any national regulatory conditions.

1 Scope

iTeh STANDARD PREVIEW

This International Standard specifies two methods of evaluating the resistance to combined shear flexing and rubbing of rubber- or plastics-coated fabrics. Rubbing is either forced by application of a pressure foot (method A), or is caused by simple contact between the faces of the test pieces (method B).

Method B (without application of the pressure foot) is preferred in all cases where the foot would damage the test piece through an abrasive effect, e.g. materials with sticky surfaces, light coatings such as polyurethanes on rough surfaces.

The test may be carried out on products as delivered or after pre-treatments such as wetting or accelerated ageing.

NOTE — The results using method A and method B should not be compared as there is no correlation between the two methods.

2 Normative references

The following standards contain provisions which, through reference in this text, constitute provisions of this International Standard. At the time of publication, the editions indicated were valid. All standards are subject to revision, and parties to agreements based on this International Standard are encouraged to investigate the possibility of applying the most recent editions of the standards indicated below. Members of IEC and ISO maintain registers of currently valid International Standards.

ISO 1302:1992 *Technical drawings — Method of indicating surface texture.*

ISO 2231:1989, *Rubber- or plastics-coated fabrics — Standard atmospheres for conditioning and testing.*

ISO 2286-1:—¹, *Rubber- or plastics-coated fabrics — Determination of roll characteristics —Part 1: Methods for determination of the length, width and net mass of a roll.*

¹) To be published. (Revision, in parts, of ISO 2286:1986)

3 Principle

A test piece is subjected to a succession of mild abrasive rubs applied to a continuously changing pattern of folds created by a rubbing machine. The damage caused to the test piece is assessed visually.

4 Apparatus

4.1 General

The apparatus shall consist of a rubbing machine (see figures 1 and 2) having two parallel clamps giving contra-reciprocating motions defined by their length and width, and a foot (optional) pressing on the flexing part of the test piece.

The apparatus shall be equipped with a counter and a device making it possible to bring the two clamps into juxtaposition manually.

Most counters, because of their method of drive, record only one impulse for one back and forth movement of the clamps, i.e. two rubbings. In this case, the number indicated by the counter shall be multiplied by 2 in order to obtain the number of rubbings (example: counter at 1 000, number of corresponding rubbings 2 000).

The components of the rubbing machine shall comply with the requirements specified in 4.2, 4.3 and 4.4.

iTeh STANDARD PREVIEW
(standards.iteh.ai)

Dimensions in millimetres

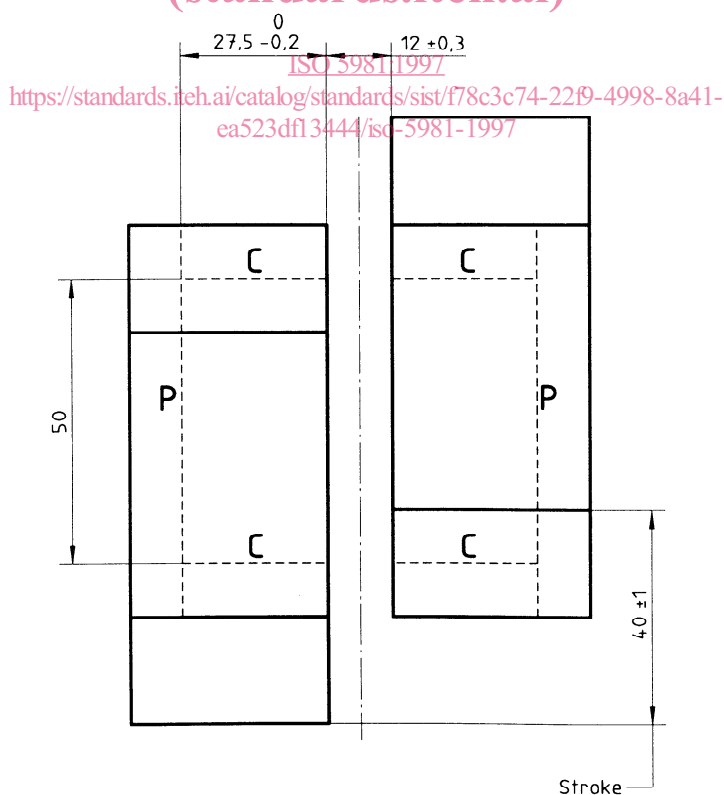

- P Shoulder of lower clamp
- C Centering line for test piece

Figure 1 — Apparatus: view from above

Dimensions in millimetres

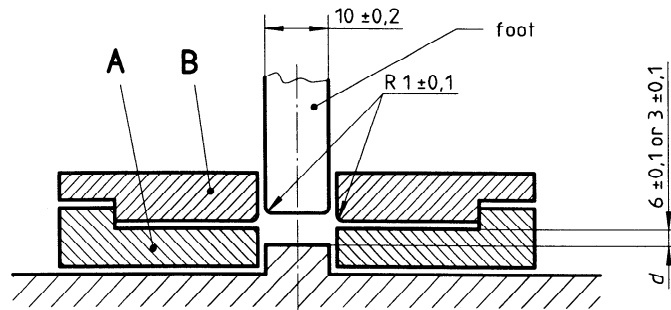

Figure 2 — Apparatus: cross-section

4.2 Dimensions and characteristics

The machine shall have the following dimensions and characteristics:

- distance between clamps: $12 \text{ mm} \pm 0,3 \text{ mm}$;
- distance d , between the base and the upper plane of the lower clamp: $6 \text{ mm} \pm 0,1 \text{ mm}$ or, agreement, $3 \text{ mm} \pm 0,1 \text{ mm}$ (for lightweight coated fabrics);
- amplitude of movement: $40 \text{ mm} \pm 1 \text{ mm}$;
- frequency of movement: 2,4 cycles/s to 3,0 cycles/s (each crossing of the clamp axes being counted as 1 rub);
- width of the foot: $10 \text{ mm} \pm 0,2 \text{ mm}$;
- length of the foot: $100 \text{ mm} \pm 1 \text{ mm}$;
- load applied through the foot: $5 \text{ N} \pm 0,1 \text{ N}$, or $10 \text{ N} \pm 0,2 \text{ N}$ by addition of a supplementary load.

All the parts or pieces of parts (except the gripping surfaces of the clamps) likely to come into contact with the test piece shall be polished (surface roughness $R_a = 0,4 \mu\text{m}$ to ISO 1302).

4.3 Clamps

The clamps shall be composed of two parts (see figures 1 and 2), as follows:

- a lower part (A), equipped with a shoulder (P), for positioning the test piece, situated at a distance of $(27,5 \text{ } ^0_{-0,2}) \text{ mm}$ from the edge of the clamp (giving the test piece a loop length of 45 mm or 55 mm), and two reference marks (C) for centering the test piece along the common axis of symmetry of the clamps when placed face to face;
- an upper part (B) serving as a clamping plate.

The edges of the clamps shall have a radius of curvature of $1 \text{ mm} \pm 0,1 \text{ mm}$, in order to avoid cutting the test pieces.

The clamping system, comprising the upper clamp on the lower clamp, shall be so designed that it is impossible for the test piece to slip during testing.

4.4 Foot (optional)

The foot (see figure 3) shall be centered between the clamps so that it is at no time in contact with them. Its edges shall have a radius of curvature of 1 mm – 0,1 mm.

The centre of gravity (G) of the foot, and of its guide system, shall be in the plane perpendicular to the clamping plane of the test piece and which passes through the common axis of symmetry of the two clamps when placed face to face. This plane shall also contain the centre of gravity of the foot alone.

The guide system for the foot shall permit movement both vertically and around the centre of gravity, the centre of gravity remaining in the plane specified above.

The load applied via the foot on the test piece shall be 5 N – 0,1 N or, by agreement between the interested parties, 10 N – 0,2 N by addition of a supplementary load.

Dimensions in millimetres

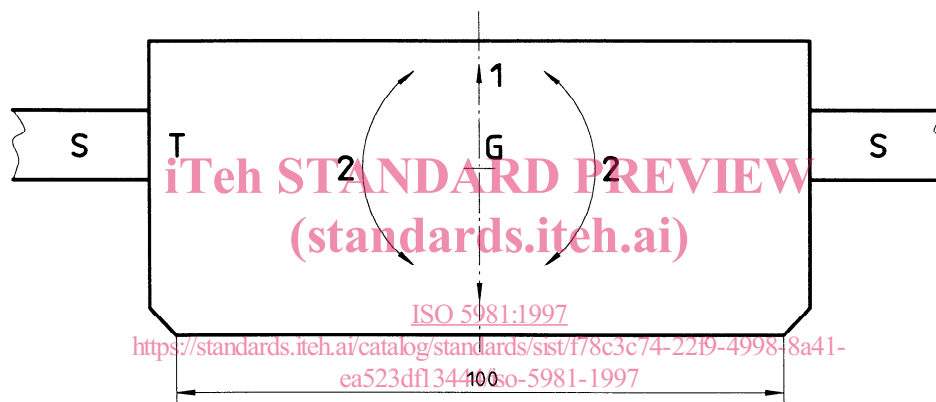

- 1 Vertical displacement
- 2 Displacement about the centre of gravity G
- S Guide system for the foot
- T Foot

Figure 3 — Pressure foot

5 Test pieces

5.1 Number

For each series of tests, take six test pieces, three in the longitudinal direction and three in the transverse direction.

In the case of fabrics coated on both sides, twice the number of test pieces shall be taken.

5.2 Shape and dimensions

5.2.1 The test pieces shall be cut to the finished test dimensions (see figure 4) and shall have the shape of a rectangle of the following dimensions:

length: 100 mm – 0,5 mm;

width: 50 mm – 0,5 mm.

Test pieces taken in the longitudinal direction shall have their length in the longitudinal direction; those taken in the transverse direction shall have their length in the transverse direction.

5.2.2 In the case of coated fabrics which have little elasticity, tearing may occur in the clamps. By agreement between the interested parties, the test can then be carried out with test pieces of length 110 mm – 0,5 mm.

Dimensions in millimetres

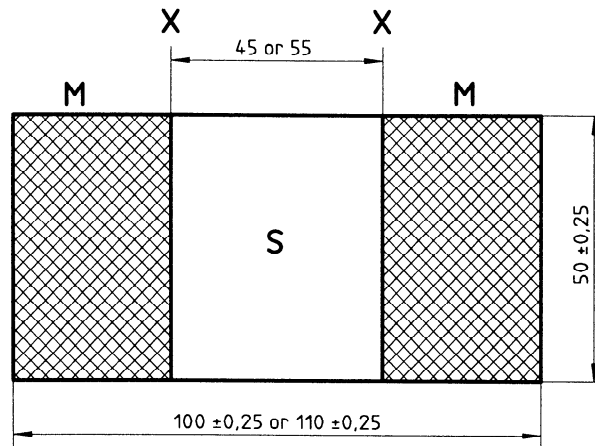

- M Location of the clamp
- S Useful area tested
- X Reference line

iTeh STANDARD PREVIEW
(standards.iteh.ai)

Figure 4 — Test piece

[ISO 5981:1997](https://standards.iteh.ai/catalog/standards/sist/f78c3c74-22f9-4998-8a41-ea523df13444/iso-5981-1997)

5.3 Sampling

<https://standards.iteh.ai/catalog/standards/sist/f78c3c74-22f9-4998-8a41-ea523df13444/iso-5981-1997>

Test pieces shall be taken from the usable width of the roll as defined in ISO 2286-1, from a place not showing any apparent defect.

6 Time interval between manufacturing and testing

6.1 For all test purposes, the minimum time between manufacturing and testing shall be 16 h.

6.2 When the test is for comparison of materials, it is strongly recommended that these periods be as close to each other as possible.

7 Conditioning and testing atmosphere

The atmosphere for conditioning and testing shall be one of the atmospheres A, B or C specified in ISO 2231.

The test pieces shall be conditioned in accordance with one of the methods in ISO 2231.

In the case of testing when wet, soaking shall be carried out in water at a temperature corresponding to the test temperature. Test pieces subjected to an accelerated ageing treatment shall be reconditioned before testing in the chosen atmosphere.

8 Procedure

8.1 Method A (with pressure foot)

8.1.1 Mark two reference lines on a test piece, parallel to the shorter sides and at a distance of $(27,5 \begin{smallmatrix} 0 \\ -0,2 \end{smallmatrix})$ mm from the edges (see X in figure 4).

8.1.2 Bring the clamps face to face by hand. Fix the test piece between the clamps so that the coated surface to be tested faces the top and the reference lines are flush with the clamps.

8.1.3 Bring the clamps opposite each other manually and apply the foot to the test piece. Check that the counter is set to zero. Set the apparatus in operation.

8.1.4 Interrupt the test from time to time to examine visually the condition of degradation of the test piece. To do this, remove the foot and carry out one or two cycles by hand whilst observing the surface of the test piece. Do not remove it from the clamps.

8.1.5 Continue the test up to a predetermined number of rubs, or until degradation of the test piece is noticeable.

8.2 Method B (without pressure foot)

Prepare and fix a test piece in the apparatus as described in 8.1.1 and 8.1.2. Set the apparatus in operation without applying the foot.

Continue the test up to a pre-determined number of rubs, or until degradation of the test piece is noticeable.

[ISO 5981:1997](https://standards.iteh.ai/catalog/standards/sist/f78c3c74-22f9-4998-8a41-ea523df13444/iso-5981-1997)

<https://standards.iteh.ai/catalog/standards/sist/f78c3c74-22f9-4998-8a41-ea523df13444/iso-5981-1997>

9 Examination of test pieces and expression of results

Remove the test piece from the clamps and examine it visually. This can be carried out with the naked eye or under a magnification of · 4 to · 6.

Note and report the type(s) of change observed and the degree of change in each case;

holes, cracks;

surface abrasion and its depth;

separation of support and coating, or separation of different layers;

permanent creasing, etc.

The changes may be evaluated directly or by comparison with a test piece of reference material.

Repeat with the remaining test pieces.

10 Test report

The test report shall include the following particulars:

- a) a reference to this International Standard, giving the method used (A or B);
- b) all details necessary for identification of the samples tested, and their date of manufacture, if known;
- c) the number of test pieces tested, the direction of cut, and their length;
- d) the face tested in the case of a fabric coated on both faces;
- e) the conditioning and testing atmosphere, and the method of conditioning, in accordance with ISO 2231;
- f) any pre-treatment of the test pieces, for example immersion in oil, accelerated ageing, etc.;
- g) the degree of magnification or whether examination was carried out with the naked eye;
- h) the number of rubs used;
- i) the type(s) of change observed and the degree in each case;
- j) any deviation from the specified procedure, by agreement between the interested parties or not.

ITeH STANDARD PREVIEW
(standards.iteh.ai)

[ISO 5981:1997](https://standards.iteh.ai/catalog/standards/sist/f78c3c74-22f9-4998-8a41-ea523df13444/iso-5981-1997)

<https://standards.iteh.ai/catalog/standards/sist/f78c3c74-22f9-4998-8a41-ea523df13444/iso-5981-1997>